

Technical Requirements:

1. Hydraulic test: 2.7Mpa in 30 seconds, no leakage and visible damage.
2. Burst pressure: ≥ 5.5 Mpa
3. Powder coated (RAL3000). The surface should be smooth, no crack, no scratch, no air bubble.

4	Bottom ring	1	ST12/δ=0.6		
3	Cylinder body	1	ST12/δ=1.5		
2	Cylinder bottom	1	ST12/δ=1.5		
1	Neck ring	1	20#		
图号		名称	数量	材料	备注
					件数 1
					重量 Kg
					比例 1:2
					图样标记
					版本 A
					共 1 张
					第 1 张
					材料
					日期
					审核
					初审
					设计
					制图
					标准
					文件号
					签字
					日期
					标记处数
					工艺审查

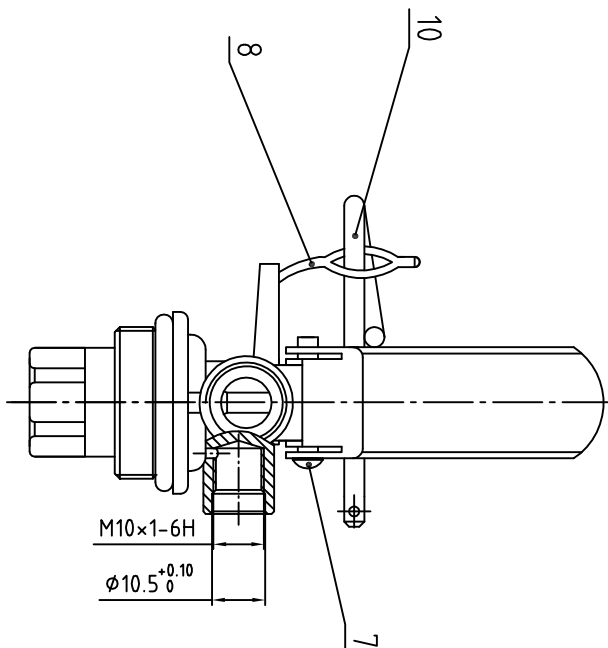
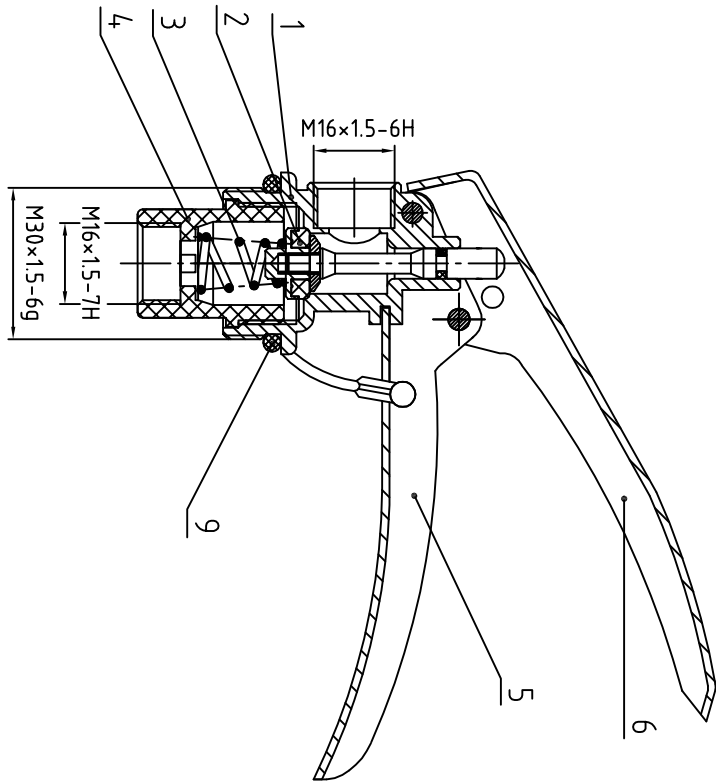

Note :

1. Valve body should be clean and without dirty dust, lever should be workable. Space between stem and lever should be more than 1.5mm when valve is close.
2. 100% valve should be tested in the water with 1.75Mpa in 30 seconds, no bubble going out.

10	Safety Pin	Q235
9	Neck O-ring	NBR
8	Rubber string	
7	Rivet	Steel
6	Press handle	ST12
5	Carrying handle	ST12
4	Dip tube holder	Nylon 6
3	Spring	Steel
2	Stem assembly	
1	Valve body	HPb 59-1
No.	Name	Remarks

					VALVE		Drawing No.	
							UY-04-00	
ZONE	REV	DESCRIPTION	SIGN	DATE	PURPOSE	WEIGHT (g)	SCALE	
DWG.					S	P		
CHK.					SHEET		OF	
APP.		ISD.						

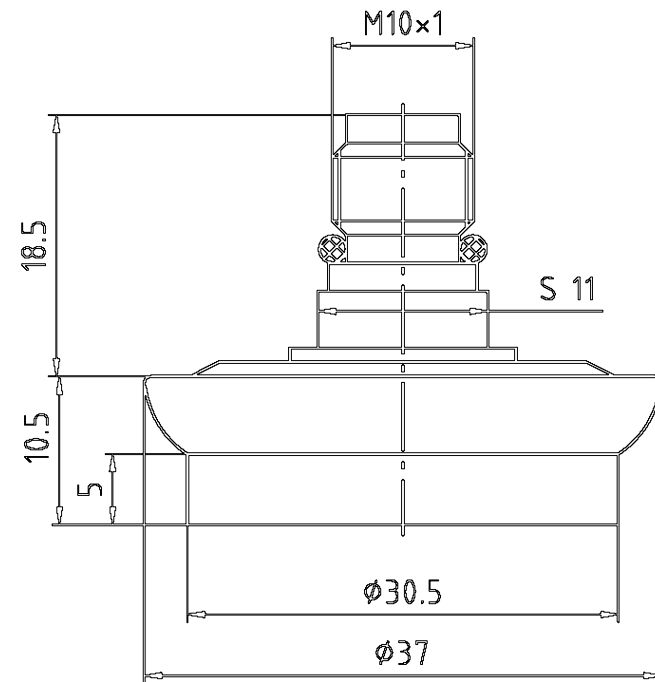
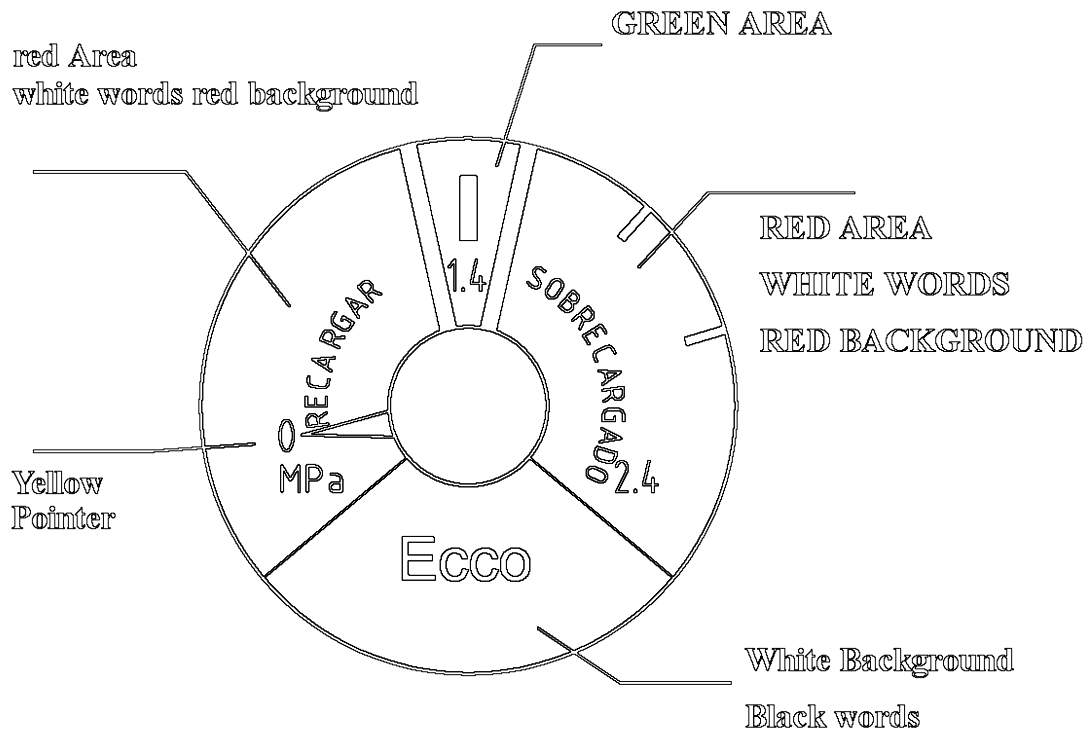

ECCO pressure gauge

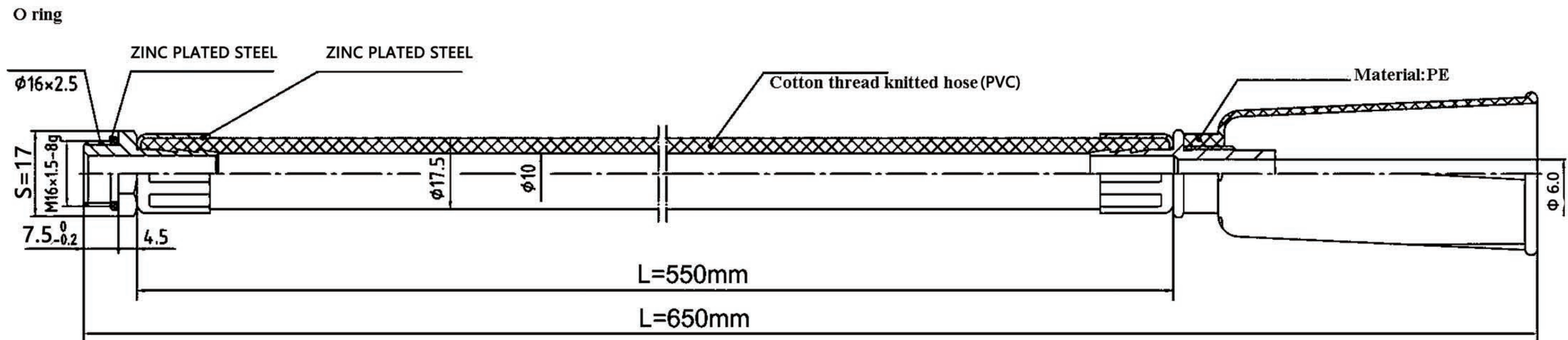

Note:

1. Connection between hose and connector should be stable, must be no leakage and damage in 2.7Mpa hydraulic pressure test.
2. Surface of hose should be smooth, hydraulic burst pressure must be more than 5.4Mpa(20°C) .

MODEL 800 HOSE ASSEMBLY

CYLINDER STAMPING

ECCO RANGE

OUTER SKIRT OF CYLINDER



1	2	3	4	5	6
Masa: X.Xkg	01/17	HX ECCO	PS: 1.4MPa	PE: 3.5MPa	Z 999999

- 1 Cylinder Weight Filled Excl. Hose
 - a. 4Kg Unit Weight = 5.8kg
 - b. 8kg Unit Weight = 10.8kg
- 2 Date of Manufacture "MM/YY"
- 3 Cylinder Manufacturer
- 4 Operating Pressure
- 5 Test Pressure
- 6 Serial Number



440±2

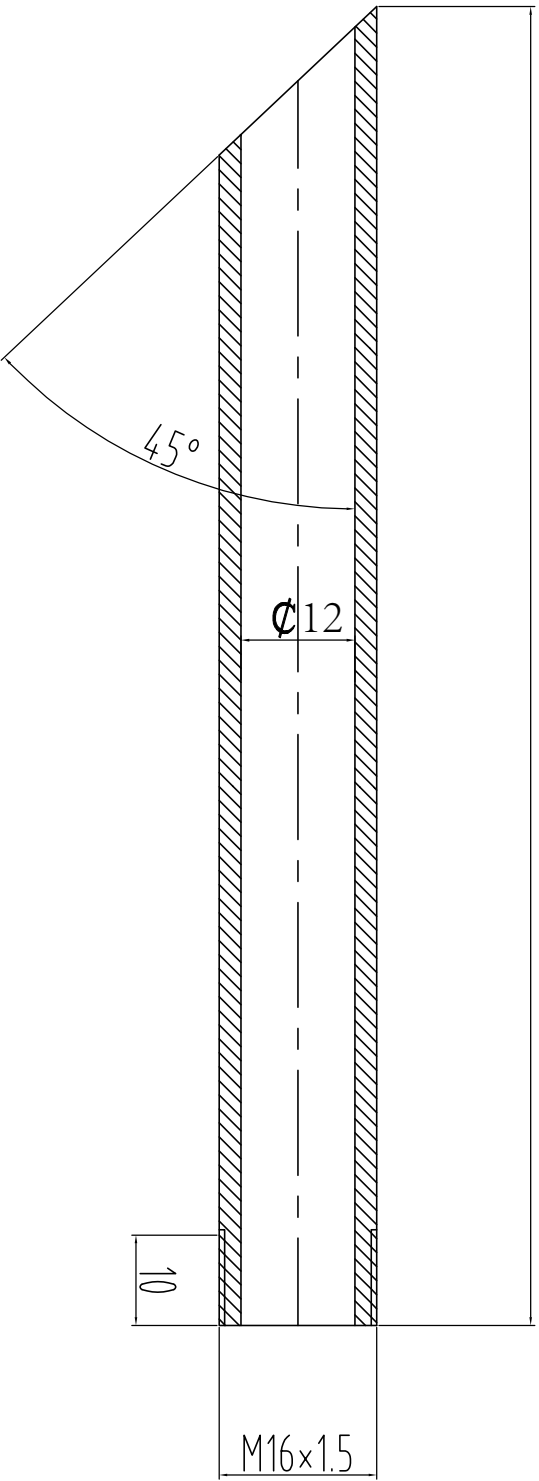

Note:

1. All surface should be smooth, no burrs, no crack.

标记		次数	分区	更改文件号	签字	日期	UY-800 DIP TUBE	图样标记	重量	比例
设计										
制图										
审核				校对	批准	日期	2013-04-24			

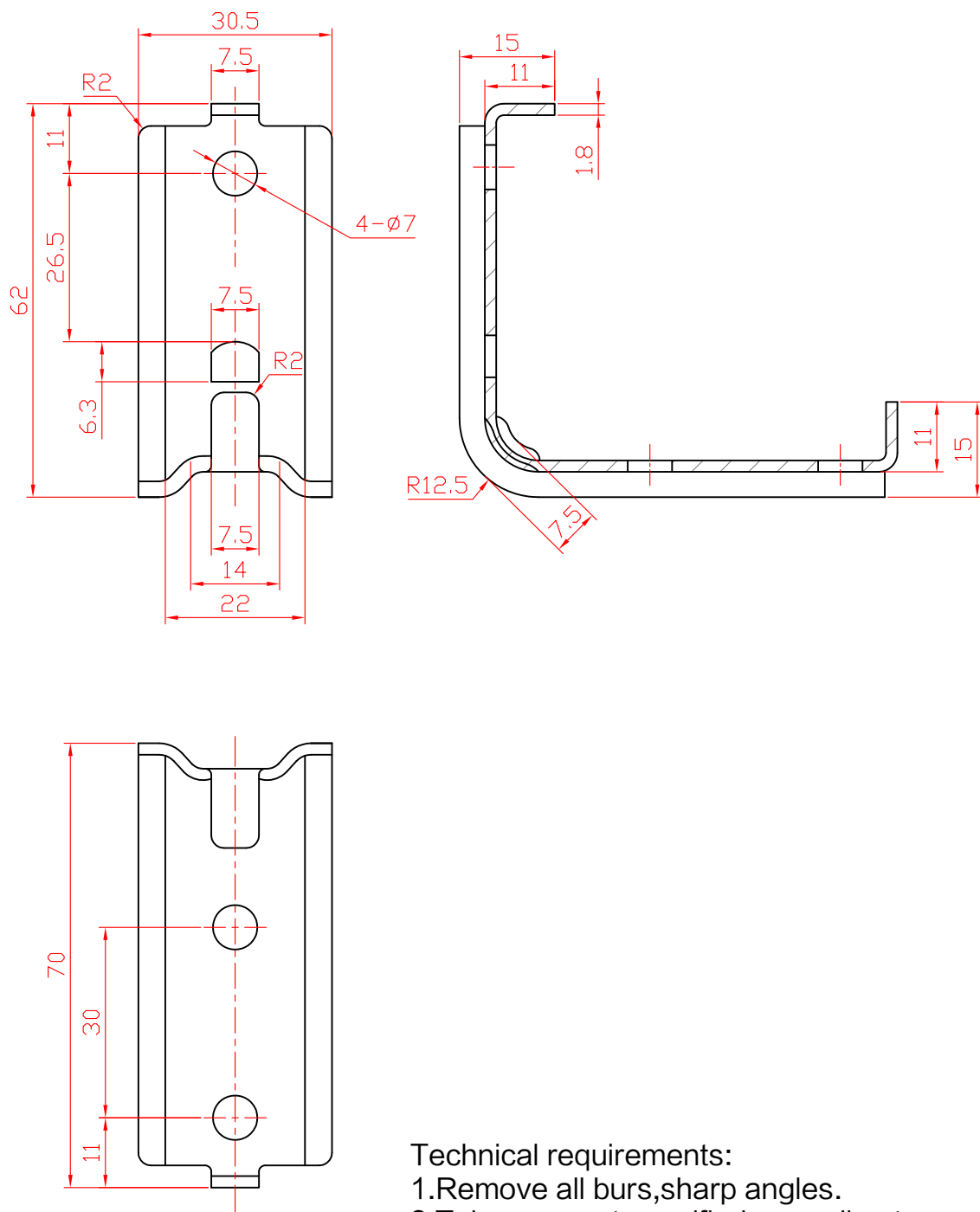

Technical requirements:
 1.Remove all burrs,sharp angles.
 2.Tolerance not specified according to F grade of GB/T 1804-2000.
 3.Zinc plated.

旧底图总号

底图总号

签字

日期

								件数	1
								重量	比例
	标记	处数	文件号	签字	日期			Kg	1:1
	设计			标准化					
	制图			描图					
	初审			描校					
	审核			审批					
	工艺审查			日期					
				材料	ST12			共 1 张	第 1 张