

## Contents

1	Introduction	2
2	Components List	4
3	Design Considerations	5
4	Installation of FirePro Generators	11
5	Connection of Multiple FirePro Generators	12
6	Installation	13
7	Control Panel Indicators & Operation	18
8	Commissioning and Test Procedure	20
9	Servicing and Maintenance	23
10	Troubleshooting	24
11	RFI Environments	25
12	Safety Data Sheet (SDS) - FirePro	26
13	Vehicle and Mobile Plant Installation Notes (AS5062)	27
14	Specifications	28



## 1 Introduction

### 1.1 General Information

The FirePro FP-08451KR Fire Control Panel is a combined detection and extinguishant system is compliant for vehicle and mobile plant installations (AS5062).

The FIP (fire indicator panel) incorporates:

- 2x Detection circuits (one 1 circuit used within EF Locos);
- 1x Extinguishing Discharge circuit;
- 1x Siren/Strobe circuit;
- 1x Agent Release Notification circuit;
- Programmable Activation (automatic and/or manual);
- Fault Monitoring system;
- Isolation Function.

KiwiRail EF Loco FirePro Suppression Systems include the FP-8451KRCC Central Crossover Panel which allows for two FP-08451KR fire control panels to operate a consolidated series of field devices. The Central Crossover Panel allows for the fire suppression system to be controlled by operators in either cab of the EF Loco.

In order to meet running capability requirements for the EF Loco's a FP-08850 Discharge Delay Module is installed. The delay provides a 30 second delay to the activation of the suppression system to allow the EF Loco engineer time to hold/prevent discharge of the system. The Discharge circuits are monitored.

The FP-08860 Siren & Shutdown Module provides a modular shutdown relay to be installed in conjunction with the FP-08451-KR & FP-8451-KRCC Fire Control Panels. The Siren & Shutdown Module allows for the fire control panel to shutdown or activate any necessary equipment when in an alarm condition. The Siren & Shutdown Module provides a volt free contact that can operate appropriately rated slave relays.

The module also includes a delay timer for the relay that has been set to 30 seconds in order to match the first delay module in the system and provide shutdown in line with system discharge.

## How Does it Work

All **FirePro** Fire Extinguishing Aerosol Generators use the latest generation FPC solid compound. Upon activation, the solid compound is transformed into a rapidly expanding, highly efficient gas, based on Potassium salts. It does not deplete oxygen levels. **Its built-in fail-safe activation system** ensures operation of the generators when required, even if everything else fails. The FirePro Aerosol Generators have a certified life of 15 years, with minimal maintenance required.

Ozone Depletion Potential (O.D.P.) = 0	Atmospheric Life Time (A.L.T.) = 0
Global Warming Potential (G.W.P.) = 0	Non-corrosive & Non-toxic

### 1.2 In Case of Fire

If a fire occurs, equipment operators should do the following:

1. Detection will initiate an alarm condition on the FirePro System
2. The siren/strobe will operate. Loco engineer will have 30 seconds in which to press the mode 2 button on the FP-8451-KR control panel to hold automatic operation of the system. While in hold mode the system can still be operated manually at any time.
3. If system discharge is allowed to go ahead uninterrupted the suppression system will discharge after 60 seconds. System shutdown will occur 30 seconds prior to suppression system discharge.
4. If hold mode is initiated during discharge the system can be operated manually as below or the EF Loco engineer can press and hold the mode 2 hold button again until one beep is heard. At this point the system will restart its activation delay as per point 3.
5. Evacuate all personnel from the risk area and alert the Fire Brigade.
6. Close all hatches and openings, and shutdown engines and any extraction fans or vents.
7. **Manual Activation:** Press and hold both mode switches continuously for 5 seconds to activate the system.
8. **Automatic Activation:** The control panel will automatically begin the activation sequence when fire has been detected on Circuit 1 Alarm.
9. Keep the FirePro suppression gas within the risk until the fire is extinguished and not able to re-ignite.
10. Do not start engine or fans until the fire is extinguished. Operating the exhaust fans will enable the gas to escape the risk area and could allow the fire to re-ignite.
11. Do not enter the risk until it has been rendered safe.
12. Following a discharge, replace all installed FirePro Generators and Thermal Fuse Couplings.

## 2 Components List

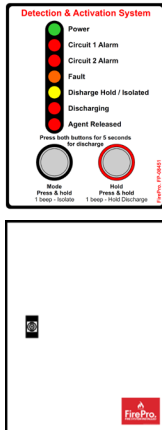

**FP-8451-KR**  
**Fire Control Panel**  
 Detection and extinguishant control system X 2

**FP-8451-KRCC**  
**Central Crossover Controller** X 1

### Agent Release Circuit      Siren / Strobe Circuit



**FP-08825**  
 Thermal Fuse Coupling



**FP-08940**  
 Siren/Strobe

### Discharge Circuit



**FirePro Aerosol Generator**  
 500g Unit.  
 Constructed from Stainless Steel.  
 Comes with installed Deutsch Plug for easy install



**FirePro Aerosol Generator**  
 3000g – 5700g Unit.  
 Constructed from Stainless Steel.  
 Comes with installed Deutsch Plug for easy install.

### Detection Circuit (Circuit 1 Alarm & Circuit 2 Alarm(NOT USED))

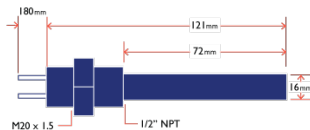

**FP-TP150**  
 Thermal Heat Probe 150° C



**FP-10543**  
 2 Hour Fire Rated Shielded Cable.

### Installation Components      Service Components



**FP-08960**  
 Signage for the System. AS 5062



**FP-08919**  
 Wiring loom and Splitter Cable for installation of multiple FirePro generators.



**FP-08850**  
 Discharge Delay Module



**FP-08860**  
 Shutdown Relay Module  
 Provides facility for equipment shutdown

### Additional Modules



**FP-8872**  
 Power Control Module  
 Provides back up power for control panel.

### 3 Design Considerations

#### 3.1 Mounting

For correct installation, the Central Crossover Controller must be mounted by four bolts or screws through the mounting holes on the inside of the enclosure. Any penetrations made through the casing of the panel should be protected using cable glands.

Dimensions and relevant clearances for installing the FP-8451KRCC Control Panel are below.

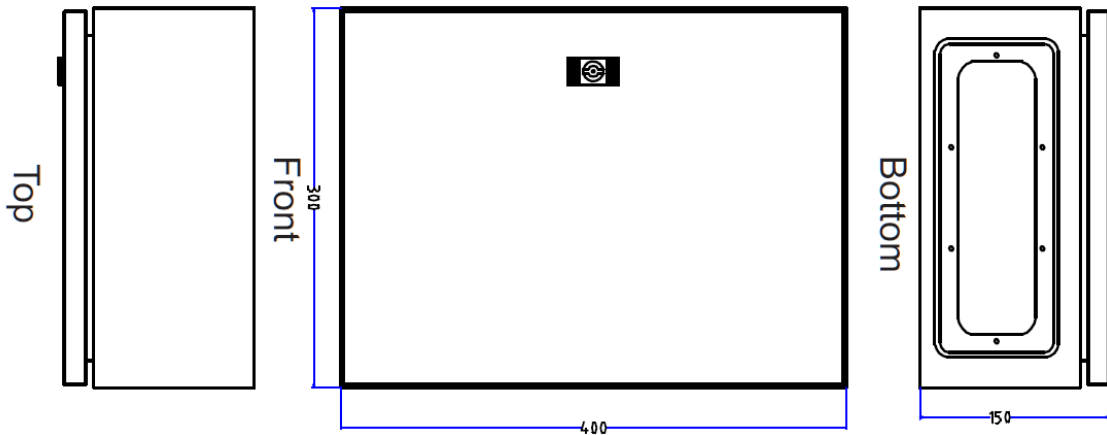

For correct installation, the FP-8451KR Fire Control Panel must be mounted by four bolts or screws through the mounting holes in the flange on both sides of the Module.

**No penetrations are to be made through the casing of the panel.**

The Fire Control Panel enclosure is rated IP65, so should be installed in a convenient location, away from where it may be affected by large amounts of water.





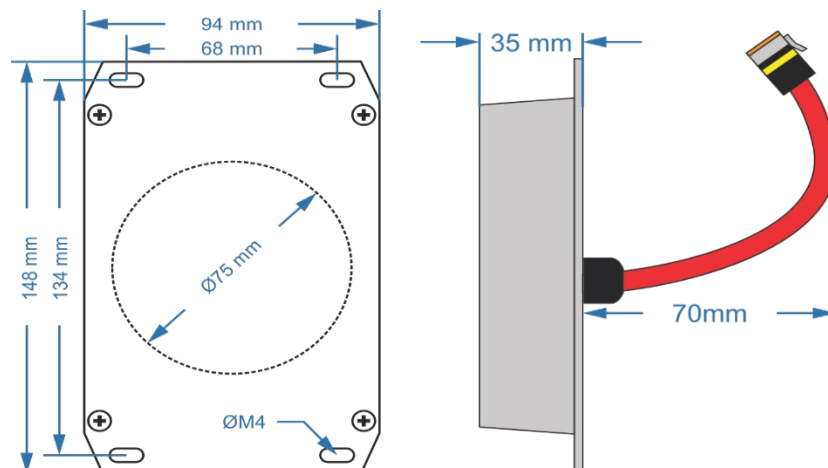



It is necessary to complete all wiring and any programming of the detection mode prior to mounting the panel.

Dimensions and relevant clearances for installing the FP-8451KR Control Panel are below. A Dash Mount Bracket (P/N FP-8451B) is also available and may be used if the minimum clearances cannot be met.

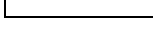

### 3.2 Cabling Requirements

Cable Requirements - All cabling in the FirePro Installation MUST be done using 0.75mm shielded Fire Rated Cable. Care taken to ensure that all cables are isolated, and that RF shielding on cable is stripped back to ensure that there is not accidental grounding. Cables are colour coded for easy identification.





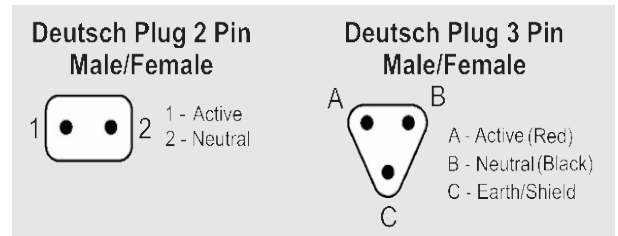



Colour	Circuit
	Red Power Supply
	Yellow 1 Activation
	Yellow 2 Activation Delayed
	Green 1 Detection 1
	Green 2 Detection 2
	Blue Discharge Advice
	Orange Siren/Strobe
	White Relay Output

Extension Leads - Deutsch Plugs must be used to ensure water-proof connections are made throughout the installation.



### 3.1 Cable Layout

Cables have been colour coded for easier identification. Colour coding is as follows:

Colour	Circuit
	Red Power Supply
	Yellow 1 Activation
	Yellow 2 Activation Delayed
	Green 1 Detection 1
	Green 2 Detection 2
	Blue Discharge Advice
	Orange Siren/Strobe
	White Relay Output
	White 2 FIP Communication

Plug arrangement on the top of the enclosure is as follows:

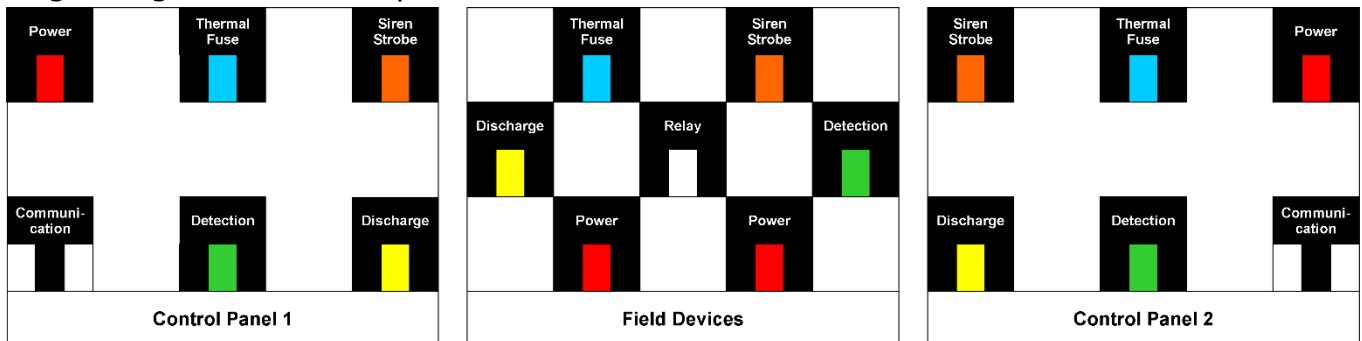

### 3.2 Power Supply Input

The Central Panel supports two power supply inputs, either one of which will operate the panel. The power supply is required to be 12 / 24vDC to operate the system.

Cabin 1												Field Devices										Cabin 2															
Fire Panel												Power												Power		Fire Panel											
1	2	3	4	5	6	7	8	9	10	11	12	+	-	3	4	5	6	7	8	9	10	+	-	1	2	3	4	5	6	7	8	9	10	11	12		

The main power supply should be connected directly to a battery or power source, not through a distribution board. The main power **must not** be interrupted if the vehicle/equipment is powered down. The FirePro Battery Lead (P/N FP-14016) may be used to connect power to the control panel.

Two secondary power supplies (P/N FP-08872) are located inside the panel that will provide backup power for 24hrs in the event the main power supply is lost.

### 3.3 Panel Communication

To communicate conditions between the connected 8451 control panels, the Central Panel provides two communication cables (marked with 2 white cable ties).

This also allows system function such as isolation, reset and manual discharge to be performed from a single 8451 control panel.

### 3.4 Discharge Delay

The Central Unit contains an inbuilt discharge delay module. Instructions for programming and operating the Discharge Delay module may be found in the FP-08850 product manual.

The discharge delay module is located behind the Power Control Module mounted on the left (as shown below). To access, the four mounting screws securing the Power control Module must be removed.

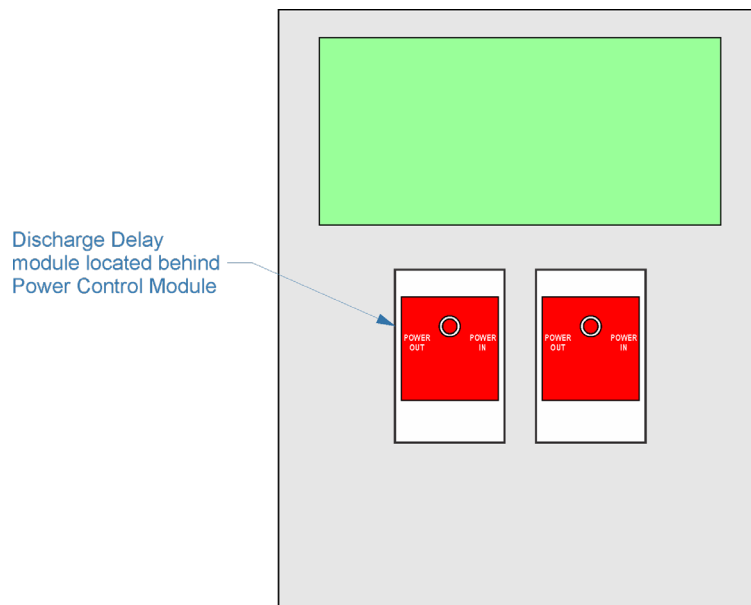

### 3.5 Control Panel Signal Connections

Connections for the signal cables from the Central Panel and the fire control panels are as follows:

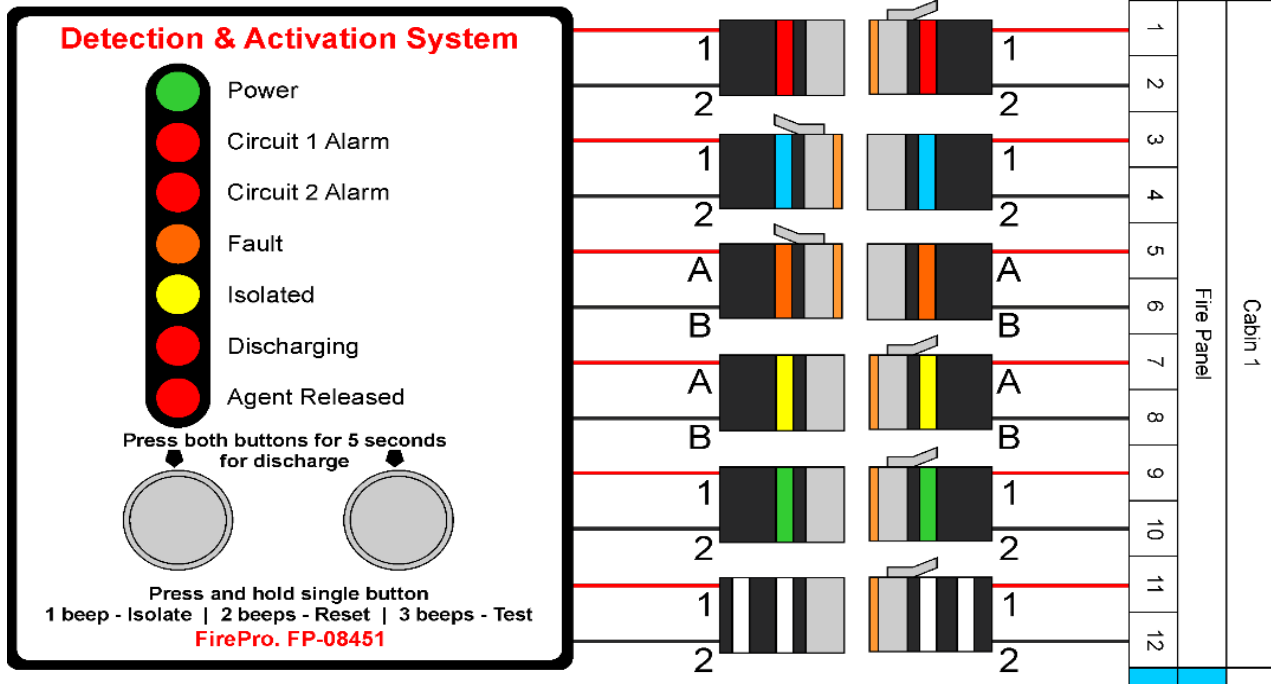

These connections are the same for both fire control panels.

Any extensions cables for these are to be completed as per section 3.2 *Cabling Requirements*. No modules or field devices are to be interposed between these connections.

### 3.6 Field Device Connections

Connection to field devices – detector(s), siren/strobe(s), thermal fuse(s), and aerosol generator(s) - are to be completed as per section 6. *Installation* of the FP-08451 Control Panel manual.

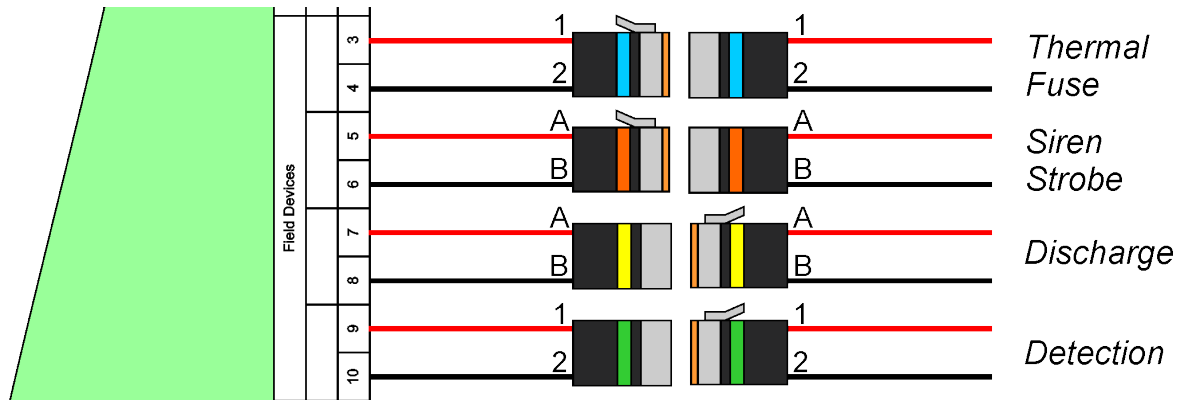

In addition, all optional modules (discharge delay and shutdown modules) are to be connected to the field device connections.

No additional power modules are to be connected. If larger backup capacity is required, contact your supplier.



### 3.7 Agent Released Input

The Agent Released input provides an indicator to the operator to notify if the suppression system has been activated. For the indicator to operate, the FP-8825 Thermal Fuse Coupling must be used. Thermal Fuse Couplings are single use only. If the suppression system has operated, the thermal fuse coupling must be replaced.

### 3.8 Siren/Strobe Output

The recommended siren/strobe is the Banshee Sounder-Strobe. In the EF Loco install, the number of sirens/strobes installed is 2. When installed, Siren/Strobes are to be clearly visible and audible in both cabs of the locomotive.

The siren/strobe output is a monitored circuit. The supplied end-of-line diode (1N4004) must be installed on the last siren/strobe in the circuit, otherwise the fire control panel will display a fault.

### 3.9 Discharge Output

The maximum number of FirePro generators able to be discharged by the FP-8451KR Fire Control Panel is limited by the voltage of the main power supply. That is:

<b>Voltage 12vDC</b> Max = 2 Units	<b>Voltage 24vDC</b> Max = 4 Units
------------------------------------	------------------------------------

If a risk area requires a greater number of FirePro generators, the FP-08850 Discharge Delay module must be used. The module will discharge generators in multiples up to the maximum as above.

**If the number of FirePro generators connected to each output is greater than the maximum, the fire system will not operate.**

When multiple FirePro generators are connected to a single output, they **must** be connected using the FP-08919 Splitter Lead.

### 3.10 Detection Output

The Detection Output is a zoned detection circuit capable of operating up to 30 conventional detectors, 100 metres of linear heat detection cable or 30 manual actuators.

The Circuit 1 Alarm Output is programmed for detection, alarm, and automatic discharge if an alarm is detected on this circuit.

The supplied end-of-line resistor (22kΩ) must be installed in the final end-of-line junction box provided.

## 3.11 Relay/Shutdown Output

In the EF Locomotive install, the number of shutdown modules installed is 1. Additional slave modules can be added as needed to a maximum of 5.

Where multiple modules are used, the modules are to be connected using the siren/strobe output (marked orange) as below. There are no limitations to the individual programming of a module when multiple modules are connected together.

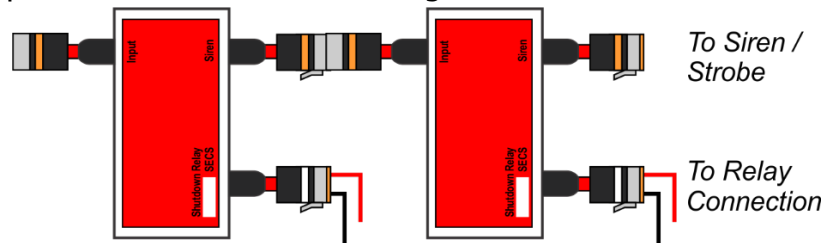

Direct connections of electrical equipment to the shutdown relay **must not** exceed the rating of the relay (30vDC 2A), as this may damage the module and fire control panel.

The relay has been set to normally open with a delay of 30 seconds.

## 3.12 Discharge Delay Output

### Normal

The "Normal" output (marked yellow 1) activates any connected FirePro generators immediately when the activation sequence begins - it is NOT affected by the delay timer.

The first discharge delay module in the EF Loco circuit provides a 30 second delay to the suppression system activation, as such the supplied 3k3Ω End-of-line resistor **must** be installed on the "Normal" output, or a fault will be displayed.

### Delayed

The "Discharge Delay" output (marked yellow 2) activates any connected FirePro generators as per the programming to the delay timer. The delay timer initiates when the control panel begins the activation sequence. When the programmed time of 30 seconds is reached, the connected FirePro generators will discharge.

## 4 Installation of FirePro Generators

### FirePro Condensed Aerosol Fire Extinguishing System Arrangement.

- FirePro units and system components installed to allow inspection and maintenance.
- Locate FirePro units where they are not exposed to mechanical damage, exposed to chemicals, or weather conditions, that may render them inoperative. Protective provisions shall be adopted, if necessary.
- FirePro units shall be securely installed. Use heavy duty brackets where necessary. Brackets should be capable of handling the risk environment, including vibration.

**FirePro units** must be installed **at NOT less than the minimum safe distances** as specified in the design calculations.

### Means for prompt rescue of any trapped personnel shall be provided, including:

- Adequate aisle ways/routes of exit.
- Alarms – audible and visual, that operate immediately on detection of the fire.
- Signs in accordance with relevant standards for the installation.

**System components** shall be positioned to the minimum clearances from energized electrical parts.

### Handling and Storage – when handling the Condensed Aerosol Generators do not:

- Disassemble the unit
- Carry out any welding work in the vicinity of the fire extinguishing system components.
- Exert force or impact which creates physical or mechanical damage to the casing.

### STORAGE and OPERATIONAL CONDITIONS

- Temperature: -54 and +54°C
- Humidity: maximum 98% RH
- Service life: 15 years (date of manufacture appears on each generator)

### Positioning

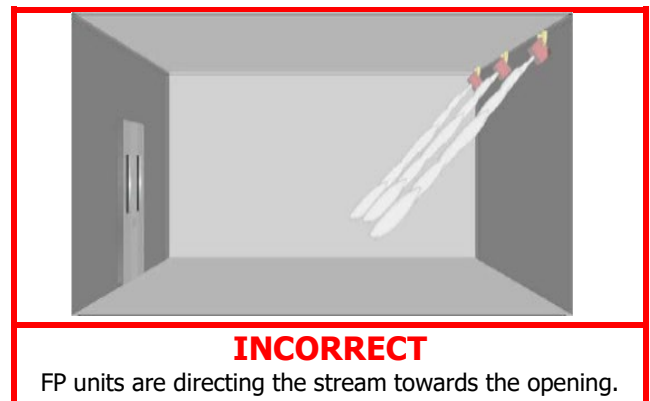
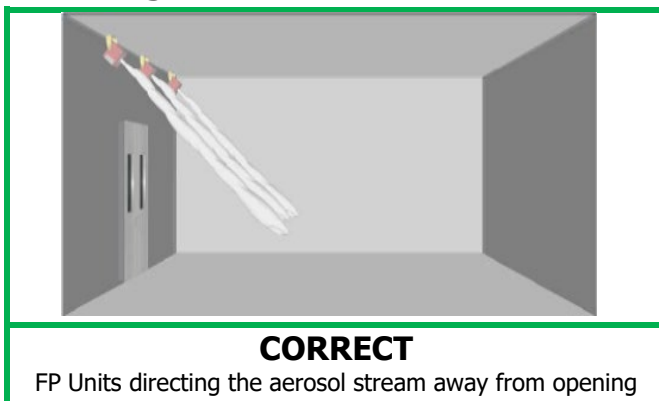

## 5 Connection of Multiple FirePro Generators

Where multiple FirePro Generators are installed, connect using the FP-8919 Splitter Lead.

Splitter Leads can be installed at any point on the activation circuit. For ease of install, servicing and efficient field wiring, Splitter Leads should be installed in areas easy to access and minimise extension leads.



**The supply voltage** of any system will determine the no of FirePro units which can be used

**12vDC**

**Max = 2 FP Units**

**24vDC**

**Max = 4 FP Units**

Where additional units are required in the system use **Discharge Delay Module(s)**.

### Connection of 2 FirePro Units

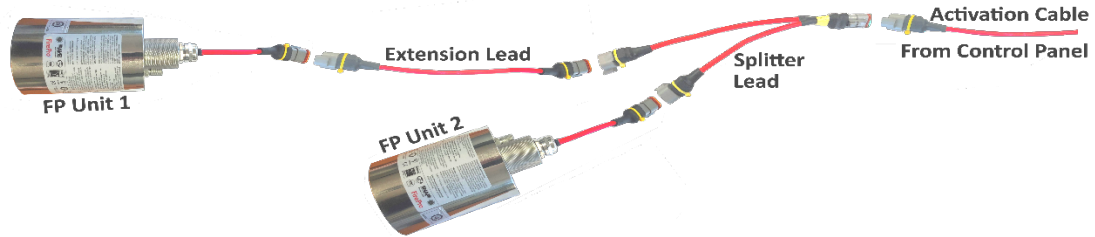

### Connection of 4 FirePro Units

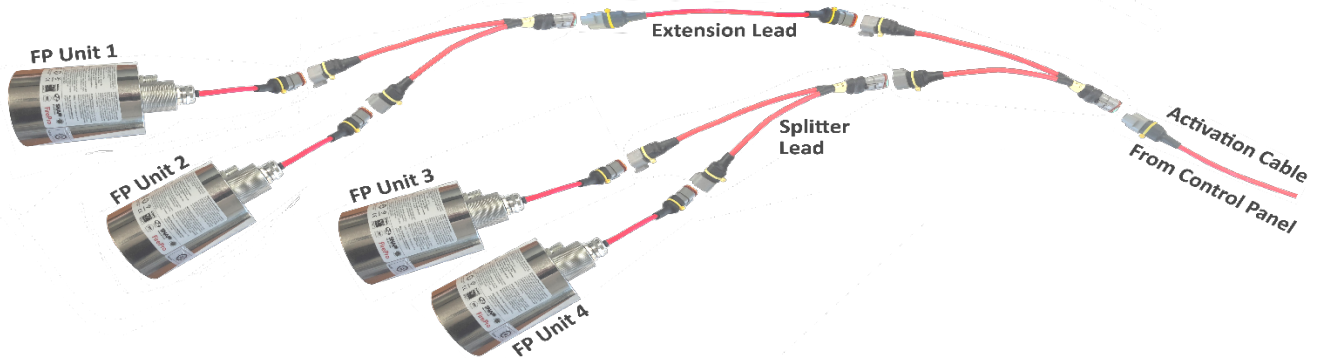

## 6 Installation

It is recommended that one circuit is installed and connected at a time to isolate the cause of any faults that may occur during installation. The use of End-of-line plugs and Test Module may be used to keep the control panel out of a fault condition during install.

The FP-8451KR Control Panels provide several programming options, allowing it to be adapted to site conditions. The 2-way DIP switches inside the panel next to the terminal block allow one of 4 modes to be selected. To access the DIP switches, open the panel enclosure.

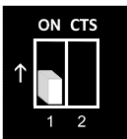
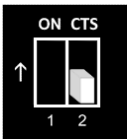
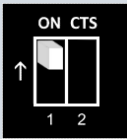
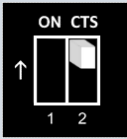
Switch 1	Mode	Switch 2	Mode
	<b>OFF</b> <b>Standard Discharge</b> Power Applied for 2 seconds		<b>OFF</b> <b>Manual Discharge</b> Detectors operate siren/strobe only
	<b>ON</b> <b>Extended Discharge</b> Power applied for 240 seconds <b>KIWIRAIL SETTING</b>		<b>ON</b> <b>Automatic Discharge</b> Detection on Circuit 1 Alarm will discharge system <b>KIWIRAIL SETTING</b>

**Note:** All programmed settings should be recorded in the logbook.

**Note:** If a Discharge Delay Module (P/N FP-08850) is installed, panel **must** be programmed for extended discharge.

- Power:** When all control panels have been mounted in a suitable location, connect main supply power to the FP-8451KRCC Central Crossover Controller as shown in section 3.1. FP-8451KR Control Panels should be connected back to the corresponding cab connections as shown in 3.5.
- Agent Released Circuit:** The Thermal Fuse Coupling (P/N FP-08825) should be screwed into the thermal port on one of the installed FirePro generators and connected to the central crossover controller panel. This port is also used for grounding of all FirePro generators to the EF Loco chassis.

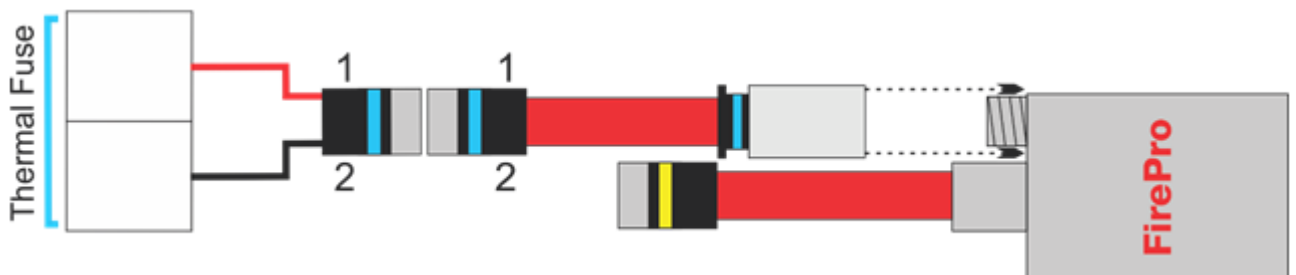

- Siren/Strobe Circuit:** Mount the siren/strobe (P/N FP-8940) in a location where it is visible and audible in each of the EF Loco’s Cabs and connect to the “Siren” output on the FP-8451KRCC (marked orange). If more than one siren/strobe is being installed, they are to be connected using the secondary positive/negative terminals in the sounder.

The supplied end-of-line diode should be installed in the secondary positive/negative terminals of the last siren/strobe in the circuit. The diode is polarised, so the positive lead of the diode (marked with a grey band) should be terminated in the positive terminal of the siren/strobe, otherwise a fault will occur on the fire control panel.

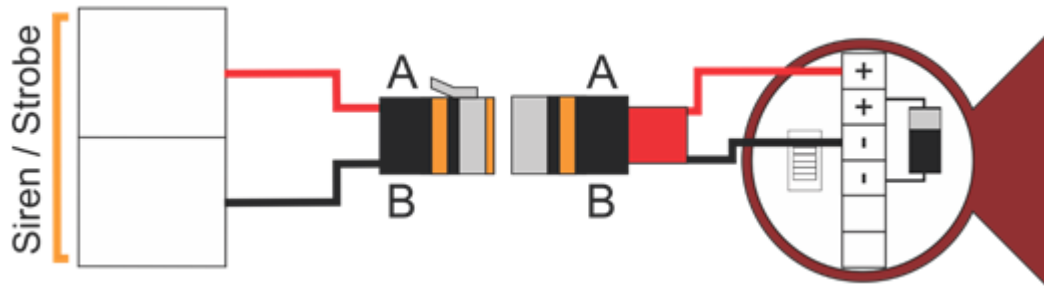

#### 4. Siren/Shutdown Module

The input cable from the FIP may be connected at any time. However, the FIP will remain in fault condition and the relay will not operate until all other steps are completed.

**Siren/strobe installed,** use an extension lead to connect the siren strobe to the “Siren” output on the FP-8451KRCC (marked orange). The supplied end-of-line diode should be installed in the unused positive/negative terminals of the last siren/strobe in the circuit. The diode is polarised, so the positive lead of the diode (marked with a grey band) should be terminated in the positive terminal of the siren/strobe, otherwise a fault will occur on the fire control panel.

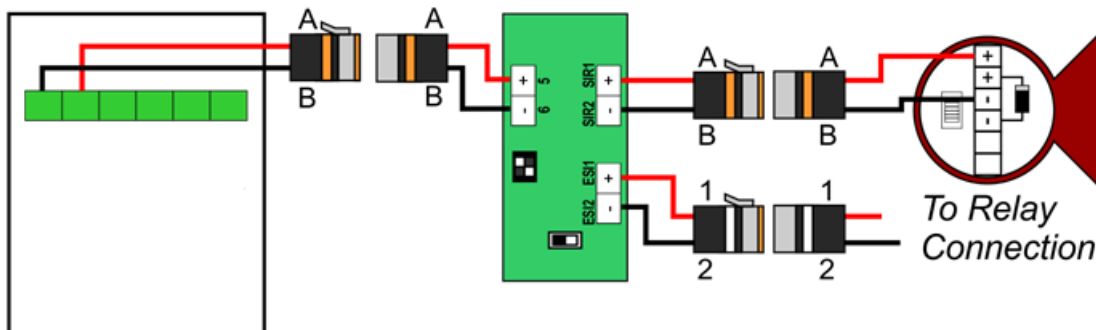

### Siren/Shutdown Programming:

The Delay Timer allows for the activation of the relay to be delayed after the panel has entered an alarm state. Where multiple modules are used, each module may have separate programming. The Siren/Strobe or end-of-line diode **must** be connected for the relay to operate.

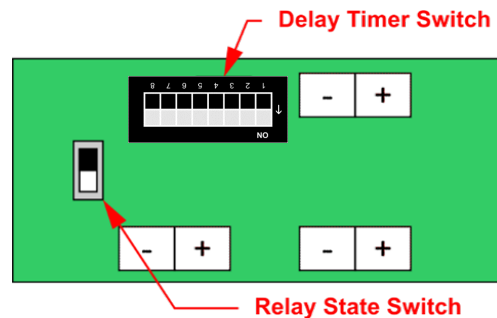

Delay Timer Switch								
Switch Number	1	2	3	4	5	6	7	8
Delay Value	1 sec	2 sec	4 sec	8 sec	16 sec	32 sec	64 sec	128 sec

The delay time is programmed by setting the required switches to the "OFF" position. If multiple switches are used, the delay values are added together, allowing for any delay time between 1 to 255 seconds to be programmed.

Example of common delay times:



Delay Time	Switch Positions
2 seconds	
15 seconds	
20 seconds	
30 seconds <small>KIWIRAIL SETTING</small>	

Delay Time	Switch Positions
60 seconds	
90 seconds	
120 seconds	
240 seconds	

Settings must be recorded in logbook and on in the space provided on the front of the module.

### Programming Relay State - Module Version 3

The Relay State Switch allows for the relay to be set to either normally open or normally closed. Where multiple modules are used, each module may have separate programming.

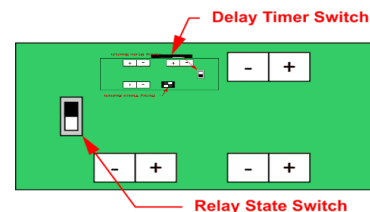

Relay State Switch	Mode
	ON <b>NORMALLY OPEN</b>

Relay State Switch	Mode
	OFF <b>NORMALLY CLOSED</b>

- Alarm Circuit:** This circuit is programmed for **AUTOMATIC DISCHARGE** (discharges suppression system and operates siren/strobe).

**Heat Detection:** Four thermal probe heat detectors are installed inside metal grounded junction boxes in various hazard areas within the EF loco. The supplied End-of-line resistor is mounted in the final thermal probe detector in the circuit.

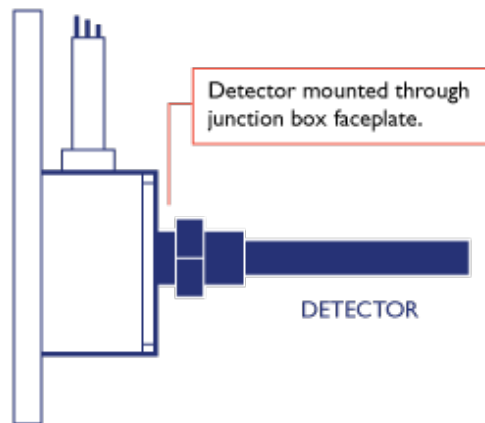

- Discharge Circuit:** This circuit should remain disconnected until all other circuits are connected. The control panel **must not** be in an alarm/fault condition when the FirePro generators are connected, as this may cause an accidental discharge. A FirePro Test Module (P/N FP-8800) should be connected to take the control panel out of fault condition and for any commissioning.

**Connecting FirePro Generators:** If a single FirePro Generator is being installed, it can be connected directly to the Discharge output on the control panel. When connecting multiple FirePro Generators please refer to instructions in section 5.0.

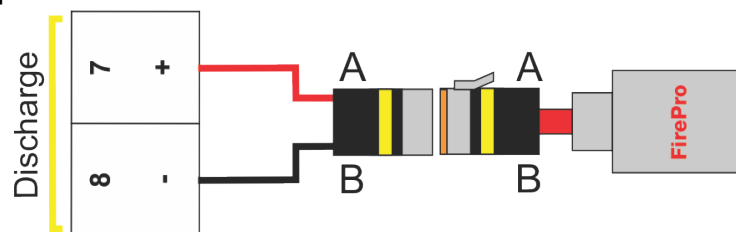



## 7. Discharge Delay Module

FirePro generators **must** remain disconnected until system is completed and fire control panel is no longer in a fault or alarm condition. The FirePro Universal Test Lamp (P/N FP-8800) can be used to take the panel out of a fault condition.

### Discharge Delay Programming:

**When using a discharge delay module, the FP-08451KR Fire Control Panels must be programmed for extended discharge.**

The Delay Timer Switch allows for the activation of the connected FirePro generators to be delayed for a period of up to 255 seconds after the FIP has entered an alarm condition. Individual programming of modules **must not** exceed 4.5 minutes (the total time power is applied to the activation circuit).

Each switch on the Delay Timer has a separate delay value (in seconds) as follows:

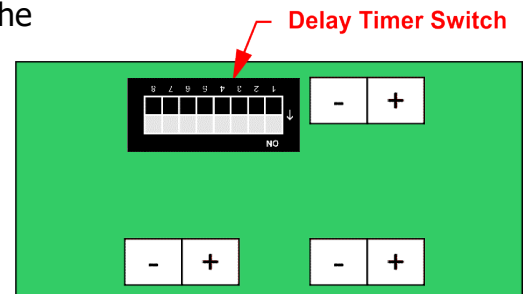

Delay Timer Switch								
Switch Number	1	2	3	4	5	6	7	8
Delay Value	1 sec	2 sec	4 sec	8 sec	16 sec	32 sec	64 sec	128 sec

The delay time is programmed by setting the required switches to the "OFF" position. When multiple switches are used, the delay values are added together, allowing for any delay time between 1 to 255 seconds to be programmed.



Example of common delay times can be programmed as follows:

Delay Time	Switch Positions	Delay Time	Switch Positions
<b>2 seconds</b>		<b>60 seconds</b> <small>KIWI RAIL SETTING</small>	
<b>15 seconds</b>		<b>90 seconds</b>	
<b>20 seconds</b>		<b>120 seconds</b>	
<b>30 seconds</b>		<b>240 seconds</b>	

**Note:** The settings of the module should be recorded in the service logbook and marked in the space provided on the front of the module.

## 7 Control Panel Indicators & Operation

### 7.1 LED Indicators

The FP-8451KR Control Panel uses LED indicators to notify the operator of the condition of the control panel and each of the monitored circuits. If an LED is illuminated, it indicates the following:

Circuit	LED	Condition
Power	Green	Power supply is available
Circuit 1 Alarm	Red	System is in alarm condition
Circuit 2 Alarm	Red	System is in alarm condition
Fault	Orange	System is in fault condition and needs servicing
Isolated	Yellow	System has been isolated or discharge held using buttons on panel
Discharging	Red	System has initiated activation sequence
Agent Released	Red	Agent has been released and needs servicing

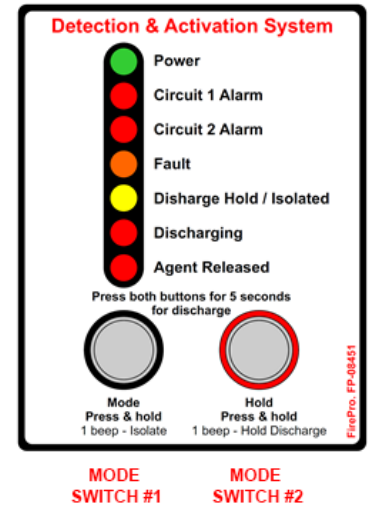

### 7.2 Isolate Function

To **isolate** the control panel, press and hold Mode Switch 1 until a 1 beep is heard and the "Isolated" LED is illuminated. To **restore** the control panel to normal operation, press Mode Switch 1 and ensure the "Isolated" LED turns off.

**Isolating disables automatic activation. Manual Activation will remain operational.**

When isolated, the control panel continues to monitor for alarm and fault, and show the alarm and fault indications, but will not operate the siren and the automatic discharge. When isolated, any change in the detector status, will cause the panel sounder to operate for 1 second as an alert of the status change, but the panel will remain isolated. The isolate function will also silence the siren/strobe and the internal sounder but will not cancel the alarm or fault indication.

### 7.3 Hold Discharge Function

To STOP/HOLD the discharge of the suppression system during activation press and hold Mode Switch 2 on the control panel until 1 beep is heard and the "Hold" LED is illuminated. To **restore** the control panel to normal operation, press Mode Switch 2 and ensure the "HOLD" LED turns off.

**Holding discharge disables automatic activation. Manual Activation will remain operational.**

When in HOLD, the control panel continues to monitor for alarm and fault, and show the alarm and fault indications, but will not operate the siren and the automatic discharge. The HOLD function will also silence the siren/strobe and the internal sounder but will not cancel the alarm or fault indication.

### 7.4 Reset Function

To reset the control panel, press and hold Mode Switch 1 until 2 beeps are heard. Following a reset, the control panel will automatically isolate. To restore the control panel to normal operation, press Mode Switch 1 and ensure the “Isolated” LED turns off. **Note:** The control panel **cannot** be reset if the activation sequence has been initiated. When the “Discharging” LED is no longer illuminated, the reset function will become available again.

### 7.5 Discharging the Fire Suppression System

To manually discharge the fire system, press and hold both Mode Switch 1 and Mode Switch 2 continuously for 5 seconds. This will immediately operate any installed siren/strobes and any shutdown relays (subject to delays), to warn any occupants. Manually discharging the fire system should only be performed during commissioning/servicing when the system has been appropriately isolated, or in case of fire.

### 7.6 Alarm Silence

To silence the internal sounder and any installed siren/strobes that have operated due to an alarm condition, press and hold Mode Switch 1 until 1 beep is heard and the “Isolated” LED is illuminated. This will also override any installed shutdown relays and allow for operation of the equipment. **Note:** Equipment should not be operated until it has been rendered safe by the appropriate authority. The control panel will remain in an alarm/fault condition until serviced and reset.

## 8 Commissioning and Test Procedure

Commissioning should be performed when the fire control panel is not in an alarm/fault condition. **Note:** No personnel should be in the risk area until the fire system is fully isolated.

To ensure that the FirePro system will operate as designed, it should be inspected and serviced every 6 months, and yearly, in accordance with AS5062.

### Six Monthly Test Procedure:

- **Isolate the control panel** and disconnect any installed FirePro aerosol generators. This will generate a fault on the fire control panel.
- **Connect FP-8800 Test Module(s)** to the "Discharge" output to the panel (marked yellow). Turn off the Isolate function. The Test Module should remain installed throughout the test procedure.

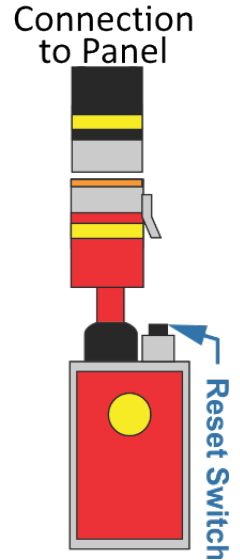

Testing of 4 FirePro Units

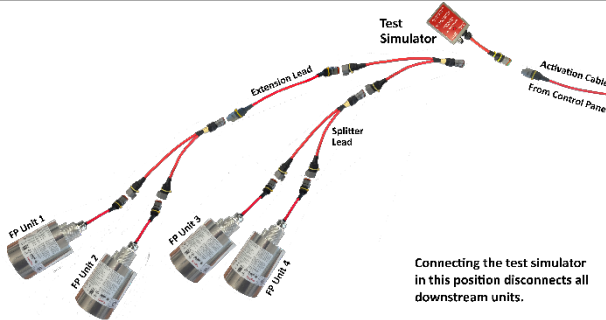

Testing of 2 FirePro Units

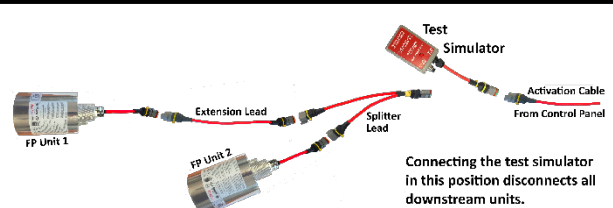

Alternate testing of 4 FirePro Units

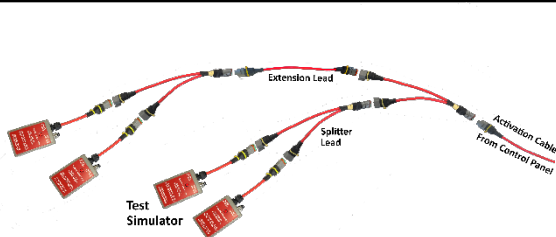

Alternate testing of 2 FirePro Units

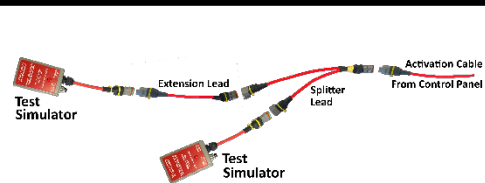

- **Control Panel and components:**

- Clean and remove dirt, grease or foreign material. Replace any parts that appear damaged or have been painted.
- Check all indicators are in normal position.

- **FirePro Aerosol Generators:**

- Inspect FirePro generators to ensure they are in good condition.
- Check mounting brackets are in good condition and secure.
- Check FirePro Units are at predetermined aiming points.

- **Electrical System Inspection:**
  - Check Manual Actuators are secure, clean, undamaged.
  - Check that anti-tamper seals/pull pins are in place and secure.
  - Check all wiring, connection and supports are in intact, undamaged and in correct position.
- **Labels:**
  - Check manual release, system warning and instruction labels are in place and legible.
- **Test the fault monitoring** system by disconnecting and reconnecting all connected detection devices and the siren strobe circuit one at a time. Ensure the "Fault" LED indicator illuminates and the internal sounder is heard each time a circuit is disconnected.
- **Discharge Testing from Control Panel:**
  - Perform a manual discharge test by pressing and holding both mode switches on the panel continuously for 5 seconds.
  - Discharge of the system will occur after the programmed delay of the first discharge delay module
  - System shutdown will occur in time with the programmed delay of this module. Ensure steps are followed as below.
  - Following activation, ensure the Test Module Red LED has operated.
  - Isolate the panel to silence alarm. Panel should now display a fault.
  - Reset Test Module. Panel should no longer be in fault condition.
  - Turn off the Isolate function.
- **Discharge Testing from External Devices:** thermal probe detection activation must be tested separately.
  - Perform an automatic discharge test by applying heat to a thermal probe in the detection line. Use only a variable temperature heat gun set to a maximum of 250°C. DO NOT use a naked flame as this could damage the unit.
  - The suppression system will begin its discharge sequence with programmed delays on discharge of 30 seconds.
  - During this delay press mode button 2 on the display panel to HOLD the discharge. Ensure HOLD function prevents discharge by waiting longer than the programmed delay.
  - Re-start automatic activation by pressing mode switch 2 until 1 beep is heard. Discharge delay will restart from this point.
  - Following the activation sequence ensure the Test Module Red LED has operated and the shutdown module operated correctly.
  - Isolate the panel to silence the alarm. The control panel should now display a fault.
  - Reset the Test Module.
  - Reset the control panel by pressing and holding a single mode switch until 2 beeps are heard. The control panel should no longer be in alarm/fault condition.

- **System control and indicating equipment.**
  - During discharge test, ensure operation of all installed siren/strobe(s).
  - During discharge test, ensure operation of all installed shutdown relays. This must shutdown any equipment specified in the risk assessment.
  - Test backup battery capacity. Replace every backup battery every 2 years.
- Disconnect the FP-8800 Test Module and reconnect all FirePro aerosol generators.
- Turn off the Isolation function. System is now operational.

### **Additional requirements for Commissioning of a System after Install or Discharge**

- **Design Survey** - check against the baseline data, for alterations, changes in use or operating environment, or other factors that could affect the performance of the fire protection system. (Annual)
- **Risk Assessment** – required to be prepared and reviewed every 5 years or after any incident. Review document to ensure system compliance. Check if document is current.

### **Testing of the Central Crossover Panel includes:**

- Ensure power switching method operates.
- Turn power on to first control panel.
- One at a time, disconnect the signal cables (excluding the power connection) and ensure the connected control panel enters a fault condition.
- Switch power to the second control panel and repeat step 3 for the second control panel.

## 9 Servicing and Maintenance

Inspection and servicing of the installed fire system should occur in accordance with the relevant New Zealand/Australian Standards (i.e. AS5062). Any alterations to the risk area should be recorded and where necessary the risk assessment, design calculation and installed components must be revised to reflect the new operating conditions.

A logbook must be kept, recording all the relevant information from the installation and servicing. The logbook must contain the following:

Content of logbook:	Appendices of Logbook:
<ul style="list-style-type: none"> <li>- General details</li> <li>- Devices used</li> <li>- Date and outcome each inspection</li> <li>- Risk Assessment</li> </ul>	<ul style="list-style-type: none"> <li>- Schematic diagrams</li> <li>- Photos of the original Installation</li> <li>- Programming of the control panel</li> <li>- Inspection reports</li> </ul>

### 9.1 Daily Service Schedule

A daily inspection should be performed by the operator prior to operation of the equipment. If anything does not appear normal, the equipment should not be operated and the fire service provider alerted. The Daily Inspection should include:

- Visual inspection of the control panel and installed components. These should be accessible and free from debris, rust, or electrical faults.
- Visual inspection of the control panel to ensure normal functioning. When functioning normally the only indicator illuminated should be the "Power" indicator (green).

### 9.2 Semi-annual / Annual Service Schedule

Semi-annual and Annual servicing and maintenance **are to be undertaken only by accredited service technicians.** Any misuse of the control panels may result in an accidental discharge of the suppression system and is not covered by warranty.

Servicing should include a visual inspection of all the installed components to ensure they are in good condition, and that the relevant stream lengths and thermal clearances are observed as per the original design calculation and risk assessment.

Operation of the fire system should be tested as outlined in 9. Commissioning.

## 10 Troubleshooting

The FP-8451KR Control Panel provides a comprehensive fault monitoring system that will detect any open-circuit in the Circuit 1 Alarm Output, Circuit 2 Alarm Output, Siren/Strobe Output, Discharge Output and Agent Released Input and any malfunctions of the control panel's internal components.

When in a fault condition, the control panel will operate the "Fault" LED indicator and operate the internal sounder. The control panel uses a coded sequence to indicate the type circuit to the operator. **Note:** To diagnose if a fault is internal or external, attempt to isolate the panel. If the control panel can be isolated, the fault is external. (see 9.2 Isolating the Control Panel).

Troubleshooting		
Problem	Possible Cause	Solution
Isolation function displaying differently on connected 8451 control panels	Communication Error	Disconnect backup power supplies and cycle main power supply.

For additional assistance, contact your supplier.

### 10.1 Fault Indicators

A fault will be indicated if any monitored circuit connected to the panel is not complete. This could be caused by the devices connected or the wiring to each device. This will display as:

Internal Sounder	Fault LED	Fault
1 beep	On	Circuit 1 Alarm
2 beeps	On	Circuit 2 Alarm
3 beeps	On	Discharge Circuit
4 beeps	On	Siren/Strobe Circuit – Version 4 Panel Only

This will require inspection and testing of connections and installed components. End-of-line plugs should be plugged directly into the panel, to return it normal condition, and then used to systematically check along the effected circuit(s). If the fault persists, contact your supplier.

### 10.2 Panel is Unresponsive

If the panel has become unresponsive, check the incoming power supply. Panel will operate down to approx. 9vDC. If incoming voltage is above this contact supplier.

### 10.3 Internal Faults

An internal fault cannot be isolated and will display as:

Internal Sounder	Fault LED	Fault
Continuous, steady beep	On	Internal 5vDC Supply OR Watch Dog Circuit
Continuous, pulsing beep	On	Internal Microprocessor

Internal faults can be rectified by powering down the panel and powering up again. This will reset the system to normal conditions. If the fault persists, contact your supplier.



## 10.4 Agent Released Fault



Refer to 3.1 Agent Released Input. If the Agent Released LED is illuminated, this indicates a fault on the Agent Release input. Typical causes are that the thermal fuse coupling has operated or has been disconnected. To test if the thermal fuse coupling has operated, check with a multi-meter for a closed circuit. Thermal Fuse couplings are single use only. If the thermal fuse coupling has operated, it must be replaced (P/N FP-8825). If the thermal fuse coupling is functioning normally and the fault persists, contact your supplier.

## 11 RFI Environments

The control panel's circuit arrangement provides protection designed for the effects of electromagnetic emissions and prevent accidental discharges of the system. Shielded, fire rated cable (FP-10543) MUST to be used throughout every installation to protect the fire system from electromagnetic emissions. Cables should be installed with appropriate clearances from any cables or equipment that may produce high levels of RF interference.

## 12 Safety Data Sheet (SDS) - FirePro

This is an EXTRACT ONLY from the full SDS. To view the full SDS go to [www.chemwatch.com.au](http://www.chemwatch.com.au).

	<p><b>HAZARDOUS SUBSTANCE. DANGEROUS GOODS.</b> <b>According to NOHSC Criteria, and ADG Code.</b></p> <p><small>CHEMWATCH HAZARD RATINGS</small></p> <table border="1"> <tr> <td>Flammability</td> <td>Low=1</td> <td>Moderate=2</td> <td>High=3</td> <td>Extreme=4</td> </tr> <tr> <td>Toxicity</td> <td>Low=1</td> <td>Moderate=2</td> <td>High=3</td> <td>Extreme=4</td> </tr> <tr> <td>Body Contact</td> <td>Low=1</td> <td>Moderate=2</td> <td>High=3</td> <td>Extreme=4</td> </tr> <tr> <td>Reactivity</td> <td>Low=1</td> <td>Moderate=2</td> <td>High=3</td> <td>Extreme=4</td> </tr> <tr> <td>Chronic</td> <td>Low=1</td> <td>Moderate=2</td> <td>High=3</td> <td>Extreme=4</td> </tr> </table> <p><small>SCALE: Min/Nil=0 Low=1 Moderate=2 High=3 Extreme=4</small></p> <div style="display: flex; justify-content: space-around;">   </div>	Flammability	Low=1	Moderate=2	High=3	Extreme=4	Toxicity	Low=1	Moderate=2	High=3	Extreme=4	Body Contact	Low=1	Moderate=2	High=3	Extreme=4	Reactivity	Low=1	Moderate=2	High=3	Extreme=4	Chronic	Low=1	Moderate=2	High=3	Extreme=4
Flammability	Low=1	Moderate=2	High=3	Extreme=4																						
Toxicity	Low=1	Moderate=2	High=3	Extreme=4																						
Body Contact	Low=1	Moderate=2	High=3	Extreme=4																						
Reactivity	Low=1	Moderate=2	High=3	Extreme=4																						
Chronic	Low=1	Moderate=2	High=3	Extreme=4																						
<p><b>PRODUCT NAME</b> CELANOVA FIREPRO</p>																										
<p><b>PRODUCT USE</b> Fire extinguishing agent.</p>																										

### POISONS SCHEDULE - None

RISK	SAFETY
<ul style="list-style-type: none"> <li>Contact with combustible material may cause fire.</li> <li>Harmful if swallowed</li> <li>Irritating to eyes and skin.</li> <li>May cause SENSITISATION by skin contact.</li> <li>Harmful to aquatic organisms may cause long- adverse effects in the aquatic environment.</li> <li>Cumulative effects may result following exposure</li> <li>May produce discomfort of the respiratory. system*</li> <li>Possible respiratory sensitiser*.</li> <li>May possibly affect fertility* (limited evidence).</li> </ul>	<ul style="list-style-type: none"> <li>Keep away from combustible material</li> <li>Avoid exposure - obtain special instructions before use.</li> <li>To clean the floor and all objects contaminated by this material use water and detergent.</li> <li>Keep away from food drink and animal feeding stuffs.</li> <li>In case of contact with eyes rinse with plenty term of water and contact Doctor or Poisons Information Centre.</li> <li>If swallowed IMMEDIATELY contact Doctor or. Poisons Information Centre (show this container or label).</li> <li>This material and its container must be disposed of as hazardous waste.</li> </ul>

### FIRST AID MEASURES

<b>SWALLOWED</b>	<ul style="list-style-type: none"> <li>If swallowed do NOT induce vomiting.</li> <li>If vomiting occurs, lean patient forward or place on left side (head-down position, if possible) to maintain open airway and prevent aspiration. Observe the patient carefully.</li> <li>Never give liquid to a person showing signs of being sleepy or with reduced awareness.</li> <li>Give water to rinse out mouth, then provide liquid slowly and as much as casualty can comfortably drink.</li> <li>Seek medical advice.</li> </ul>
<b>EYE</b>	<ul style="list-style-type: none"> <li>If this product comes in contact with the eyes:</li> <li>Wash out immediately with fresh running water.</li> <li>Ensure complete irrigation of the eye.</li> <li>Seek medical attention without delay; if pain persists or recurs seek medical attention.</li> <li>Removal of contact lenses after an eye injury should only be undertaken by skilled personnel.</li> </ul>
<b>SKIN</b>	<ul style="list-style-type: none"> <li>If skin contact occurs:</li> <li>Immediately remove all contaminated clothing, including footwear.</li> <li>Flush skin and hair with running water (and soap if available).</li> <li>Seek medical attention in event of irritation.</li> </ul>
<b>INHALED</b>	<ul style="list-style-type: none"> <li>If dust is inhaled, remove from contaminated area.</li> <li>Encourage patient to blow nose to ensure clear passage of breathing.</li> <li>If irritation or discomfort persists, seek medical attention.</li> </ul>

## 13 Vehicle and Mobile Plant Installation Notes (AS5062)

For AS5062 vehicle installations, a risk assessment must be completed, and the design agreed upon by the installer and operators. The risk assessment should include identification of all fuel and ignition sources, and these must be considered in the system design.

### **AS 5062 requires:**

**Automatic Discharge:** The system shall be programmed for automatic discharge on alarm unless it is determined by the risk assessment why automatic discharge would be inappropriate.

**Equipment Shutdown:** As determined by the risk assessment, any equipment that may impede operation of the fire system must be shutdown prior to system discharge. This requires the installation of the FP-08860 Shutdown Relay Module.

**Secondary Power Supply:** In addition to the power supply requirements as per 3.1 Power Supply Input, AS5062 also requires a secondary power supply capable of operating the fire system for a minimum of 24 hours. This requires the installation of the Power Control Module, or the identification of a secondary power source in the equipment that will not be affected by any failure of the primary power supply.

**System Discharge Advice:** AS5062 requires independent notification of the suppression system discharged. This requires the installation of the FP-08825 Thermal Fuse Coupling.

**Manual Actuation:** Should manual actuators must be installed on Circuit 1 Alarm to allow for remote manual activation of the suppression system. This requires the installation of FP-14053 Manual Actuators and Circuit 1 Alarm to be programmed for automatic discharge.

## 14 Specifications

<b>General</b>	<b>Dimensions</b>	148L x 84W x 35D mm	
	<b>Material</b>	Diecast Aluminium, UV Tolerant	
	<b>Ingress Protection</b>	IP65	
	<b>Operating Temperature</b>	-40 to 85 degrees Celsius	
	<b>Fault Monitoring – External</b>	<ul style="list-style-type: none"> <li>- Circuit 1/2 Alarm – Open/Closed</li> <li>- Siren/Strobe – Open/Closed</li> <li>- Discharge – Open/Closed</li> </ul>	
	<b>Fault Monitoring – Internal</b>	<ul style="list-style-type: none"> <li>- Poly-switch fuse operated</li> <li>- Loss of internal 5V supply</li> <li>- Internal microprocessor malfunction</li> </ul>	
<b>Power Supply Input</b>	<b>Mains Operating Voltage</b>	12-30VDC	
	<b>Mains Operating Current</b>	20mA on 12V	23mA on 24V
	<b>Backup Power</b>	See FP-08870 / 08871 / 08872 manual	
<b>Detection Output</b> Circuit 1 Alarm & Circuit 2 Alarm	<b>No. of Detection Zones</b>	2	
	<b>Operating Voltage</b>	12-30VDC (same as main supply voltage)	
	<b>Detection End-of-line</b>	27kΩ / 22kΩ ½W Resistor	
	<b>Maximum Detectors per Zone</b>	<ul style="list-style-type: none"> <li>- 30 Conventional Detectors</li> <li>- 100m Linear Heat Detection</li> <li>- 30 Manual Actuators</li> </ul>	
	<b>Alarm Threshold</b>	3.6V Fault sensing threshold: 0.53V	
	<b>Compatible Detectors</b>	Hochiki SLV-AS Smoke Detector Hochiki DCD-AE3M Thermal Detector 14053 Manual Actuator 09510 180°C Linear Heat Detection	
<b>Discharge Output</b>	<b>Discharge Output Current</b>	1.5A at 12vDC	1.5A at 24vDC
	<b>Discharge End-of-line</b>	3K3Ω ½W Resistor	
	<b>Max FirePro Units</b>	2 at 12vDC	4 at 24vDC
	<b>Standard Discharge Delay</b>	5 seconds from automatic/manual activation	
	<b>Max Discharge Delay Modules</b>	2 DDM's at 12vDC	4 DDM's at 24vDC
	<b>Max FirePro units using DDM's</b>	6 at 12vDC	20 at 24vDC
<b>Siren/Strobe Output</b>	<b>Siren/Strobe Output Current</b>	Max 0.5A	
	<b>Siren/Strobe Output Protection</b>	0.5A poly-switch resettable fuse	
	<b>Siren/Strobe End-of-line</b>	1N4004 Diode	
	<b>Max Siren/Strobes</b>	5	
	<b>Compatible Siren/Strobes</b>	Banshee Sounder Strobe	
	<b>Max Siren Shutdown Modules</b>	2 at 12vDC	4 at 24vDC
<b>Agent Released Input</b>	<b>Input Type</b>	Thermal Switch, NC, Latching, Non-resettable	
	<b>Operation</b>	Thermal Event >80°C	

BANSHEE multi-tone sounder/strobe - suitable for internal or external locations.



IP 66

Specifications		
Voltage:	9 – 30vDC	
Current:	12v - Max 60mA	24v - Max 39mA
Sound Output:	101dB(A)	
Beacon:	0.7j	
Flash Rate:	60/min (1Hz)	
Temperature:	-20 C to +55 C	
IP Rating:	FP-08940 – IP 45	FP-08941 – IP 66