

1 Introduction

The FirePro SIGMA XT-A, conventional fire alarm control panel with Extinguishant Control Unit and Aerosol Agent Controller, is designed to comply with AS7240-2, AS7240-4 Fire Detection and Fire Alarm Systems - Control and Indicating Equipment, and AS ISO 14520.1 2009 Gaseous Fire Extinguishant Systems.

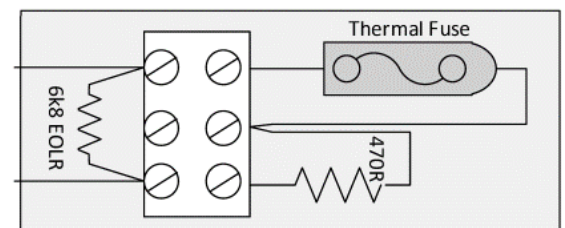



The thermal fuse is required by AS-4487 as an indicator that the system has activated.

This thermal fuse is mounted in a cast alloy enclosure, and this is rated to IP65. The mounting of the unit will determine the final IP rating. It designed for use at temperatures between -5°C (+/- 3) and $+40^{\circ}\text{C}$ (+/-2) and with a maximum relative humidity of 95%.



2 Installation

2.1 For FirePro Generators FP-1200S to FP-5700S range for products after 2023

<p>1</p>	<p>Remove the Thermal Connector Cover.</p> <p>Thermal Port configuration has changed in units after supplied 2024.</p> <p>Thermal Sensor FP-08828 is required</p>		
<p>2</p>	<p>Install the Thermal Sensor FP-08828</p>		 <p>Thermal Sensor</p>
<p>3</p>	<p>Install the Thermal Fuse Assembly FP-08826</p> <p>Connect cable to the SYSTEM ACTIVATED circuit at the FIP.</p>		 <p>Thermal Fuse Assembly</p>

2.2 For FirePro Generators FP-1200S to FP-5700S range for products prior 2023

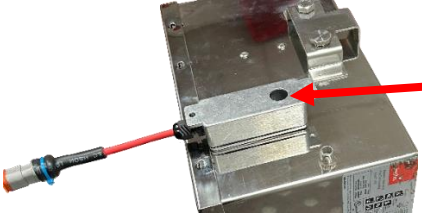
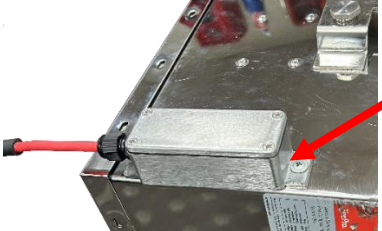
<p>1</p>		<p>Thermal fuse should be mounted on the most convenient – or closest FirePro unit to the FIP. Only one thermal fuse is required in each system.</p> <p>Remove the Cap</p>
<p>2</p>		<p>Place the hole in the thermal fuse over the thermal port in the FP Unit.</p>
<p>3</p>		<p>Add a screw to hold into position.</p> <p>Note</p> <ul style="list-style-type: none"> • there is a 25mm gap on the inside of the FP unit. • The FP unit is made from 304SS so drill pilot hole.

2.3 Thermal Fuse Connection

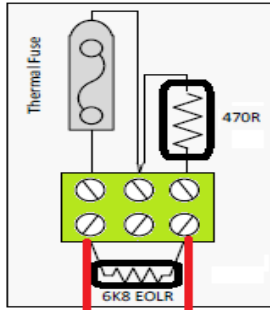

The Thermal Fuse provides notification to a control panel that a FirePro unit has activated. It should be installed in accordance with the instructions included in the relevant FirePro document.

Menu setting in the XT card allows for a normally closed (inverted) input to be used(10.3.16).

Cables connected using 3 Pin Deutsch Plugs

To Pressure Switch input for System Released Indication

Connect Thermal Fuse to Rel.P Switch

2.4 Thermal Fuse connection when 2 Thermal Fuses installed

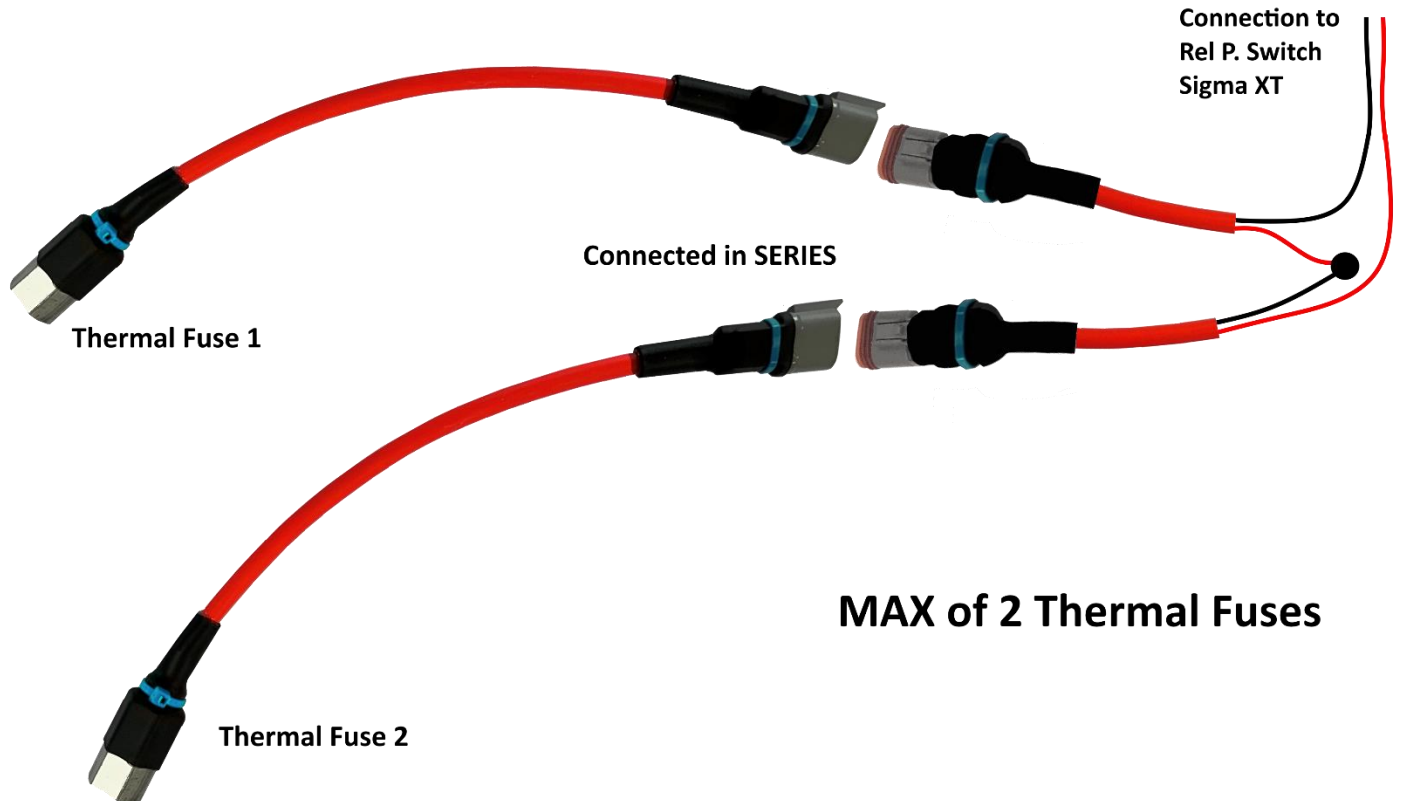

MAX of 2 Thermal Fuses

2.5 Released Indication

It is possible to select whether the released indication on a module is operated at the same time as the extinguishant release outputs operate or by operation of a pressure switch connected to the released, pressure switch input.

The factory default setting is for the released indication to be operated by operation of a pressure switch connected to the pressure switch input.

To change, open the *Display Window* and slide the *Write Enable* switch on the module to be configured gently to the right. Press the *Enter* button on the extinguishant module then press the "+" button until the display shows:

**RELEASE IND ON
RELEASED INPUT**

**RELEASED IND ON
EXTING. REL ?**

To change press *Enter*. To save, slide the *Write Enable* switch to the right.

2.6 Release Pressure Switch – Normal/Invert

To enable released pressure switches to be used which have normally closed rather than normally open contacts, it is possible to invert the released pressure switch input. The factory default setting is for the pressure switch input to use a normally open contact.

To invert, open the *Display Window* and slide the *Write Enable* switch to the left. Press the *Enter* button on the extinguishant module then press the "-" button until the display shows:

**RELEASED INPUT
MODE = NORMAL**

To Change Press the *Enter* button.

The released pressure switch input needs to be disconnected to bring it into fault before changing from Normal to Inverted or back in order to prevent the input from activating









**RELEASED INPUT
MODE – INVERTED ?**

To save, slide the *Write Enable* switch to the right. The released pressure switch input will now require a normally closed contact via a 470R trigger resistor and 6K8 end of line resistor for correct supervision.

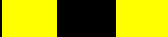
3 Cabling Requirements

Cable Requirements - All cabling in the FirePro Installation MUST be done using 0.75mm shielded Fire Rated Cable. Care taken to ensure that all cables are isolated, and that RF shielding on cable is stripped back to ensure that there is not accidental grounding. Cables are colour coded for easy identification.

Extension Leads - Deutsch Plugs must be used to ensure water-proof connections are made throughout the installation.

Colour	Circuit
	Red Power Supply
	Yellow 1 Activation
	Yellow 2 Activation Delayed
	Green 1 Detection 1
	Green 2 Detection 2
	Blue Discharge Advice
	Orange Siren/Strobe
	White Relay Output

Deutsch Plug 2 Pin Male/Female



Deutsch Plug 3 Pin Male/Female

