

# MTU ENERGY PACK

## USER MANUAL

REV 1.0

**FP-08451 Fire System Control Panel**

**FP-08800 FirePro Test Module**

**FP-08825 Thermal Fuse**

**FP-08860 Shutdown Module**

**FP-08872 Battery Backup**

**FP-09510 Linear Heat Detection**

**FP-0500S FirePro Aerosol Unit**



**FirePro.**

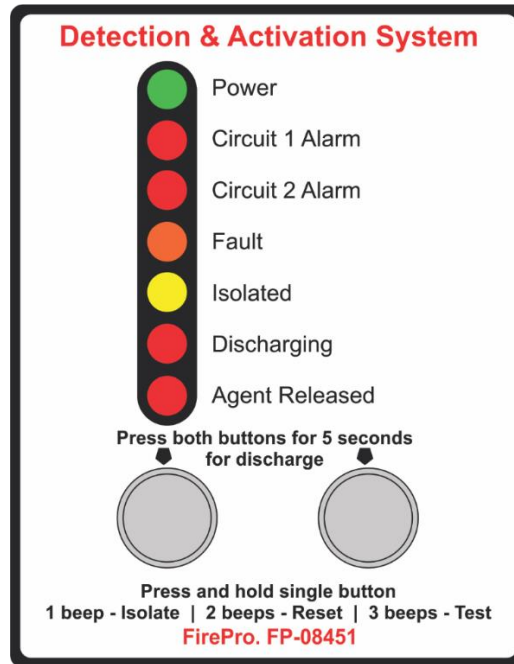

## Contents

1	Introduction	2
2	Components List	3
3	Design Considerations	4
4	Installation of FirePro Generators	7
5	Connection of Multiple FirePro Generators	8
6	Installation	9
7	Wiring Diagram	11
8	Programming	12
9	Control Panel Indicators & Operation	12
10	Commissioning and Test Procedure	14
11	Servicing and Maintenance	16
12	Troubleshooting	17
13	RFI Environments	18
14	Safety Data Sheet (SDS) - FirePro	18
15	Vehicle and Mobile Plant Installation Notes (AS5062)	19
16	Specifications	20



## 1 Introduction

### 1.1 General Information

The FirePro FP-08451 Fire Control Panel is a combined detection and extinguishant system is compliant for vehicle and mobile plant installations (AS5062).

The FIP (fire indicator panel) incorporates:

- 2x Detection circuits;
- 1x Extinguishing Discharge circuit;
- 1x Siren/Strobe circuit;
- 1x Agent Release Notification circuit;
- Programmable Activation (automatic and/or manual);
- Fault Monitoring system;
- Isolation Function.

#### How Does it Work

All **FirePro** Fire Extinguishing Aerosol Generators use the latest generation FPC solid compound. Upon activation, the solid compound is transformed into a rapidly expanding, highly efficient gas, based on Potassium salts. It does not deplete oxygen levels. **Its built-in fail-safe activation system** ensures operation of the generators when required, even if everything else fails. The FirePro Aerosol Generators have a certified life of 15 years, with minimal maintenance required.

Ozone Depletion Potential (O.D.P.) = 0

Atmospheric Life Time (A.L.T.) = 0

Global Warming Potential (G.W.P.) = 0

Non-corrosive & Non-toxic

### 1.2 In Case of Fire

If a fire occurs, equipment operators should do the following:

1. Detection will initiate an alarm condition on the FirePro System
2. The siren/strobe will operate and if shutdown relays have been installed, equipment shutdown will be initiated.
3. Evacuate all personnel from the risk area and alert the Fire Brigade.
4. Close all hatches and openings, and shutdown engines and any extraction fans or vents.
5. **Manual Activation:** Press and hold both mode switches continuously for 5 seconds to activate the system.
6. **Automatic Activation:** The control panel will automatically begin the activation sequence when fire has been detected on Circuit 1 Alarm.
7. Keep the FirePro suppression gas within the risk until the fire is extinguished and not able to re-ignite.
8. Do not start engine or fans until the fire is extinguished. Operating the exhaust fans will enable the gas to escape the risk area and could allow the fire to re-ignite.
9. Do not enter the risk until it has been rendered safe.
10. Recommended clean up after discharge is with soapy water or cleaning agent based on citric acid.
11. Following a discharge, replace all installed FirePro Generators and Thermal Fuse Couplings.

## 2 Components List

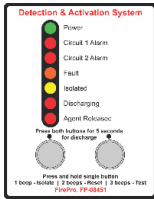

**FP-CP-08451**  
**Fire Control Panel**  
Detection and extinguishant control system

- 2x DP-3000      Deutsch Plug 3 Pin M/F, c/w heatshrink
- 4x DP-2000      Deutsch Plug 3 Pin M/F, c/w heatshrink
- 2x FP-08950      End-of-line Plug 27kΩ ½W (Detection)
- 1x                    End-of-line Diode 1N4004 (Siren/Strobe)
- 1x                    End-of-Line Resistor 3k3Ω ½W (Discharge)
- 1x                    Operator's Manual

### Agent Release Circuit      Siren / Strobe Circuit



**FP-08825**  
Thermal Fuse Coupling  
See 3.2 Agent Released



**FP-08940**  
Siren/Strobe

### Discharge Circuit



**FirePro Aerosol Generator**  
100g – 500g Unit.  
Constructed from Stainless Steel.  
Comes with installed Deutsch Plug for easy install



**FP-6200**  
Heavy Duty Bracket 316 SS.  
Suits FP-100, 200, 500 FirePro Aerosol Generators.



**FirePro Aerosol Generator**  
1200g – 5700g Unit.  
Constructed from Stainless Steel.  
Comes with installed Deutsch Plug for easy install.



**FP-6100**  
Heavy Duty Bracket 316 SS.  
Suits FP-1200, 2000, 3000 5700 FirePro Aerosol Generators.

### Detection Circuit (Circuit 1 Alarm & Circuit 2 Alarm)



**FP-08920**  
Marine Grade Thermal Detector 60°C Fixed. Other temperatures available on request.



**FP-14053**  
Manual Actuator  
Internal OR External



**FP-9510**  
Linear Heat Detection Cable 182° C  
Supplied in Cut Lengths with Deutsch Plugs for easy install. Lengths: 1,2,4,6 & 8m

### Installation Components      Service Components



**FP-09500**  
2 Hour Fire Rated Shielded Cable.



**FP-08960**  
Signage for the System. A sheet of different size labels.



**FP-08919**  
Wiring loom and Splitter Cable for installation of multiple FirePro generators.



**FP-08800**  
FirePro Simulator – for Testing & Commissioning.

### Additional Modules



**FP-08850**  
Discharge Delay Module  
Allows additional FirePro generators to be discharged



**FP-08860**  
Shutdown Relay Module  
Provides facility for equipment shutdown



**FP-08870/8871/8872**  
Power Control Module  
Provides back up power for control panel.



**FP-08879**  
Voltage Sensitive Relay

## 3 Design Considerations

### 3.1 Power Supply Input

The FP-08451 Fire Control Panel provide a single power supply input that is compatible with 12 / 24vDC. The main power supply should be connected directly to a battery or power source, not through a distribution board. The main power **must not** be interrupted if the vehicle/equipment is powered down. The FirePro Battery Lead (P/N FP-14016) may be used to connect power to the control panel. If a secondary power supply is required for an installation, a Power Control Module will be required.

### 3.2 Agent Released Input

The Agent Released input provides an indicator to the operator to notify if the suppression system has been activated. For the indicator to operate, the FP-08825 Thermal Fuse Coupling must be used. Thermal Fuse Couplings are single use only. If the suppression system has operated, the thermal fuse coupling must be replaced. If the Agent Release output is not used, the circuit must be bridged out and sealed using the supplied deutsch plugs.

### 3.3 Siren/Strobe Output

The recommended siren/strobe is the Banshee Sounder-Strobe. In a typical install, the maximum number of supported sirens/strobes that can be installed is 5. When installed, Siren/Strobes are to be clearly visible and audible at all points around the risk area.

The siren/strobe output is a monitored circuit. The supplied end-of-line diode (1N4004) must be installed on the last siren/strobe in the circuit, otherwise the fire control panel will display a fault. If a siren/strobe is not used, the supplied end-of-line diode (1N4004) must be connected to the siren output using the supplied Deutsch plugs.

### 3.4 Discharge Output

The maximum number of FirePro generators able to be discharged by the FP-08451 Fire Control Panel is limited by the voltage of the main power supply. That is:

<b>Voltage 12vDC</b> Max = 2 Units	<b>Voltage 24vDC</b> Max = 4 Units
------------------------------------	------------------------------------

If a risk area requires a greater number of FirePro generators, the FP-08850 Discharge Delay module must be used. The module will discharge generators in multiples up to the maximum as above.

**If the number of FirePro generators connected to each output is greater than the maximum, the fire system will not operate.**

When multiple FirePro generators are connected to a single output, they **must** be connected using the FP-08919 Splitter Lead. If a suppression system is not used, the supplied end-of-line resistor (3k3Ω) must be connected to the Discharge output using the supplied deutsch plugs.

### 3.5 Circuit 1 Alarm Output

The Circuit 1 Alarm Output is a zoned detection circuit capable of operating up to 30 conventional detectors, 100 metres of linear heat detection cable or 30 manual actuators. The Circuit 1 Alarm Output can be programmed for detection and alarm, or for automatic discharge if an alarm is detected on this circuit. The end-of-line resistor (22k or 27kΩ) must be installed on the last detector or manual actuator in the circuit, or the fire control panel will display a fault. The end-of-line plug (marked green) must be connected.

### 3.6 Circuit 2 Alarm Output

The Circuit 2 Alarm Output is a zoned detection circuit capable of operating up to 30 conventional detectors, 100 metres of linear heat detection cable or 30 manual actuators. The Circuit 2 Alarm Output is a detection and alarm circuit only. When in alarm condition the siren/strobe will operate, however the suppression system will not discharge until manually operated. The end-of-line resistor (22kΩ) must be installed on the last detector or manual actuator in the circuit, or the fire control panel will display a fault. The end-of-line plug (marked green) must be connected.

### 3.7 Agent Release Notification – Thermal Fuse

The thermal fuse is required by AS-5062 as an indicator that the system has activated. The thermal fuse should be mounted on the most convenient – or closet FirePro unit to the Control Panel. Only one thermal fuse is required in each system. The fuse is mounted in a stainless steel enclosure, and this is rated to IP65. It designed for use at temperatures between -5°C (+/- 3) and +40°C (+/-2) and with a maximum relative humidity of 95%. The fuse is a means of indicating to the FIP that the system has operated. It has no ability to activate the system.



**SINGLE USE ONLY – CANNOT BE RESET**

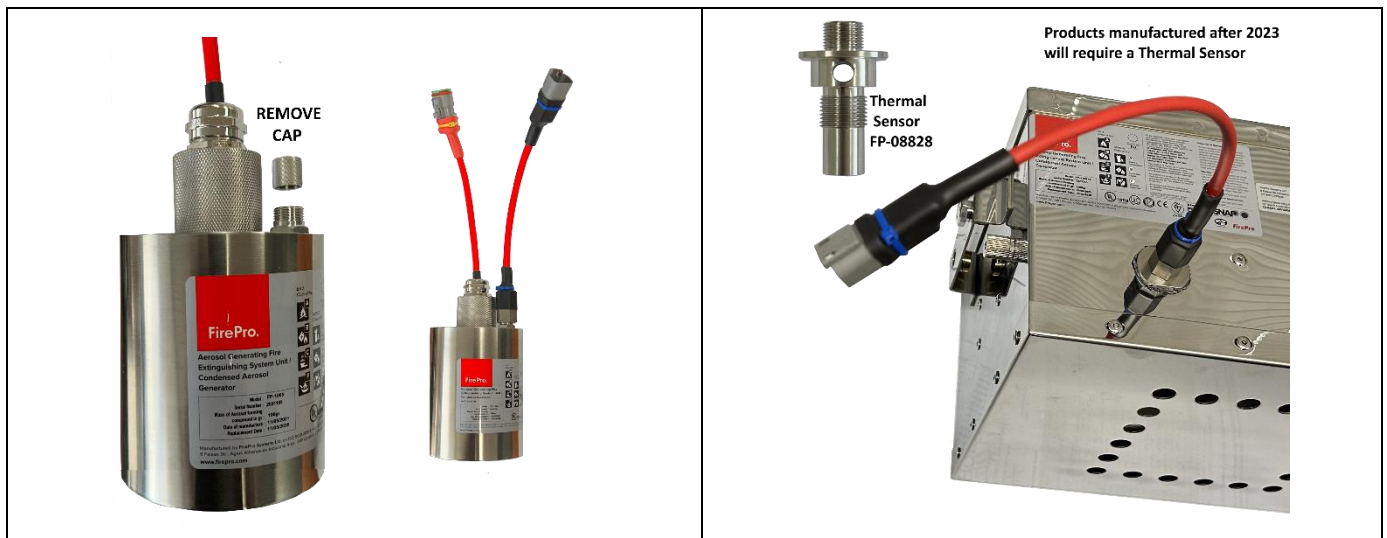

### 3.8 Mounting

For correct installation, the Fire Control Panel must be mounted by four bolts or screws through the mounting holes in the flange on both sides of the Module. **No penetrations are to be made through the casing of the panel.**

The Fire Control Panel enclosure is rated IP65, so should be installed in a convenient location, away from where it may be affected by large amounts of water.

It is necessary to complete all wiring and any programming of the detection mode prior to mounting the panel.

Dimensions and relevant clearances for installing the FP-08451 Control Panel are below. A Dash Mount Bracket (P/N FP-08451B) is also available and may be used if the minimum clearances cannot be met.

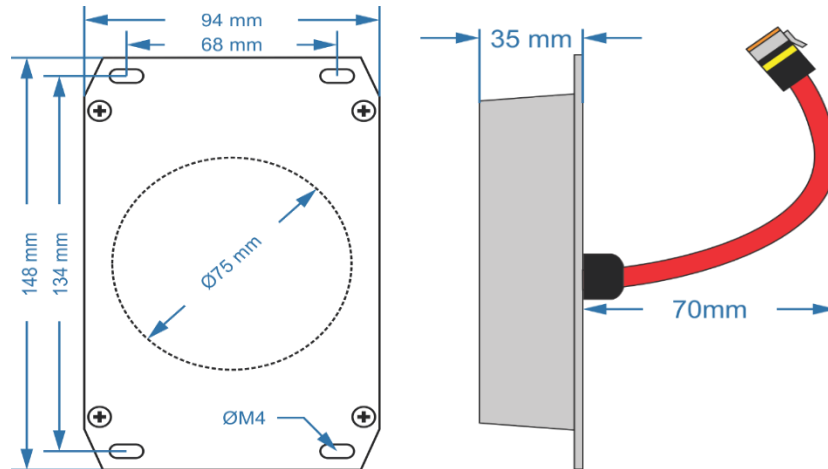

### 3.9 System Test Point

Due to regular testing requirements, it is good practice to install a System Testing point. This is a break in the activation cable from the control panel. Attach Deutsch plugs which allow the FirePro Simulator to be connected. Locate where it is easy to access and be signed as **"FirePro System Test Point"**. **The benefit is that all FirePro units in the system will be disconnected for testing, so the chance of accidental activation during testing is reduced.** It creates a process which is easy to follow for anyone working on the system.

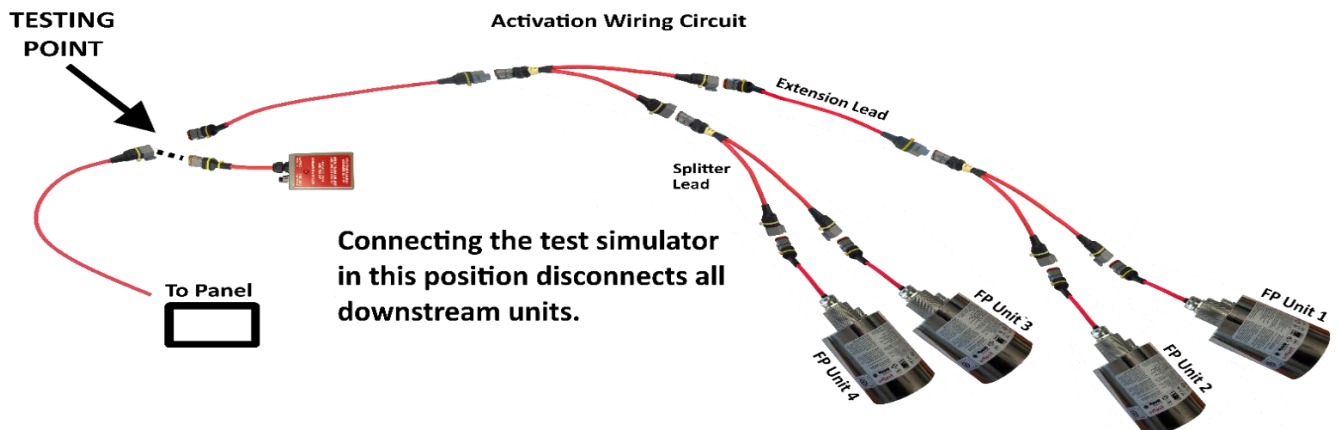

### 3.10 Cabling Requirements

Cable Requirements - All cabling in the FirePro Installation MUST be done using 0.75mm shielded Fire Rated Cable. Cables are colour coded for easy identification.

Colour	Circuit
Red	Power Supply
Yellow	Activation
Yellow with black stripe	Activation Delayed
Green	Detection 1
Green with black stripe	Detection 2
Blue	Discharge Advice
Orange	Siren/Strobe
White	Relay Output

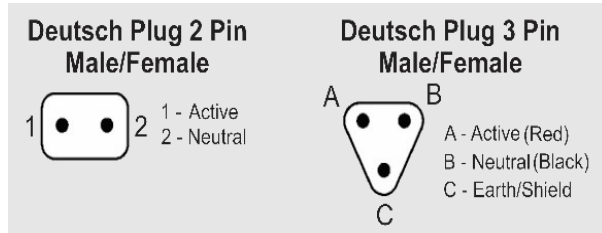

Deutsch Plugs must be used to ensure water-proof connections are made throughout the installation.

## 4 Installation of FirePro Generators

### FirePro Condensed Aerosol Fire Extinguishing System Arrangement.

- FirePro units and system components installed to allow inspection and maintenance.
- Locate FirePro units where they are not exposed to mechanical damage, exposed to chemicals, or weather conditions, that may render them inoperative. Protective provisions shall be adopted, if necessary.
- FirePro units shall be securely installed. Use heavy duty brackets where necessary. Brackets should be capable of handling the risk environment, including vibration.

**FirePro units** must be installed **at NOT less than the minimum safe distances** as specified in the design calculations.

### Means for prompt rescue of any trapped personnel shall be provided, including:

- Adequate aisle ways/routes of exit.
- Alarms – audible and visual, that operate immediately on detection of the fire.
- Signs in accordance with relevant standards for the installation.

**System components** shall be positioned to the minimum clearances from energized electrical parts as per: AS 4487 and AS 3000.

### Handling and Storage - when handling the Condensed Aerosol Generators do not:

- Disassemble the unit
- Carry out any welding work in the vicinity of the fire extinguishing system components.
- Exert force or impact which creates physical or mechanical damage to the casing.

### STORAGE and OPERATIONAL CONDITIONS

- Temperature: -54 and +54°C
- Humidity: maximum 98% RH
- Service life: 15 years (date of manufacture appears on each generator)



## Positioning



**CORRECT**

FP Units directing the aerosol stream away from opening

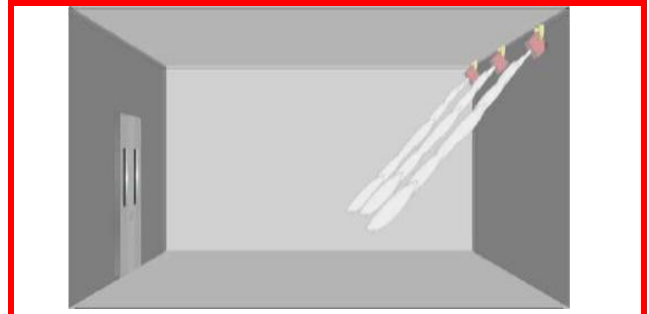

**INCORRECT**

FP units are directing the stream towards the opening.

## 5 Connection of Multiple FirePro Generators

Where multiple FirePro Generators are installed, connect using the FP-08919 Splitter Lead.

Splitter Leads can be installed at any point on the activation. For ease of install, servicing and efficient field wiring, Splitter Leads should be installed in areas easy to access and minimise extension leads.



**The supply voltage** of any system will determine the no of FirePro units which can be used

**12vDC**

**Max = 2 FP Units**

**24vDC**

**Max = 4 FP Units**

Where additional units are required in the system use **Discharge Delay Module(s)**.

### Connection of 2 FirePro Units

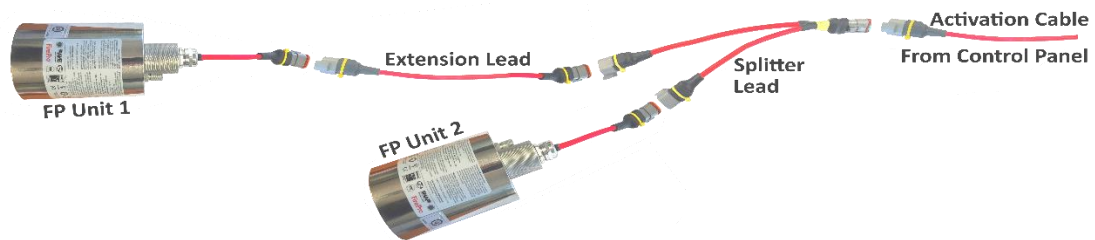

### Connection of 4 FirePro Units

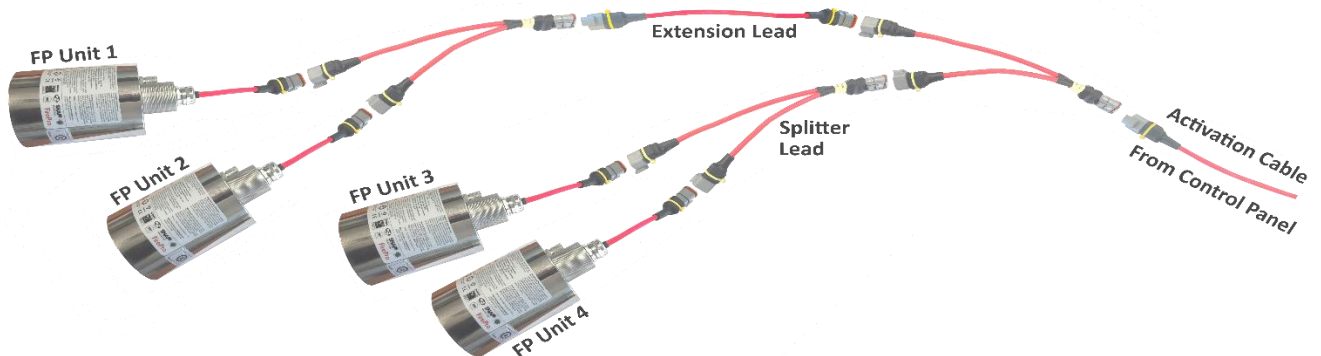

## 6 Installation

It is recommended that one circuit is installed and connected at a time to isolate the cause of any faults that may occur during installation. The supplied End-of-line plugs and Test Module may be used to keep the control panel out of a fault condition.

- Power:** When panel has been mounted in a suitable location, connect main supply power using a FP-14016 Battery Lead to the power input (marked red).

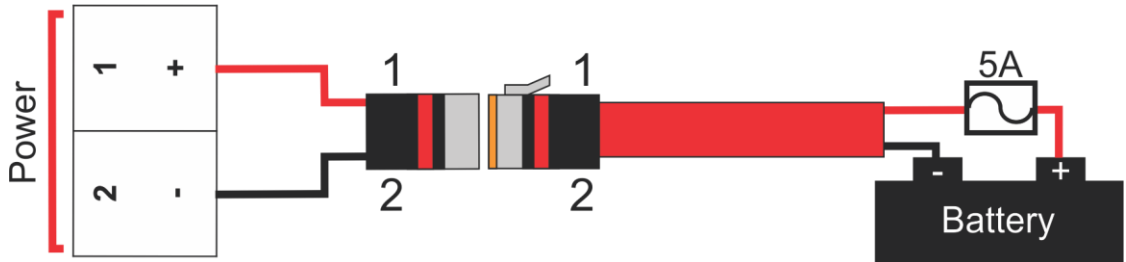

- Agent Released Circuit:** The Thermal Fuse Coupling (P/N FP-08825) should be screwed into the thermal port on one of the installed FirePro generators and connected to the control panel.

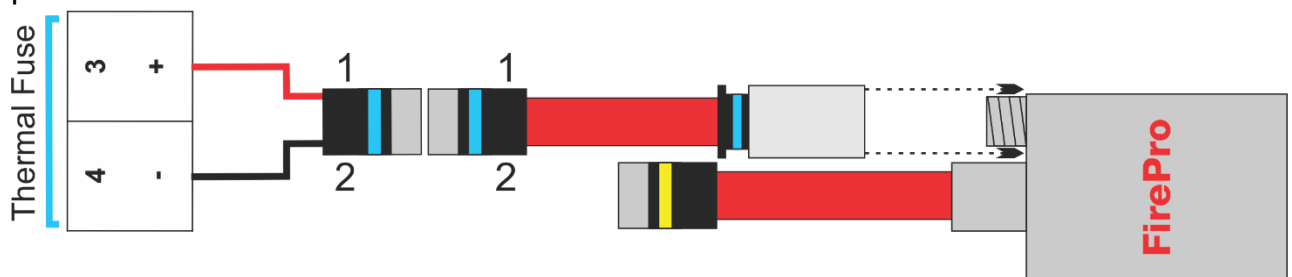

- Siren/Strobe Circuit:** Mount the siren/strobe (P/N FP-08940) in a location where it is visible and audible in all points with the risk area and connect to the "Siren" output on the module (marked orange). If more than one siren/strobe is being installed, they are to be connected using the secondary positive/negative terminals in the sounder.

The supplied end-of-line diode should be installed in the secondary positive/negative terminals of the last siren/strobe in the circuit. The diode is polarised, so the positive lead of the diode (marked with a grey band) should be terminated in the positive terminal of the siren/strobe, otherwise a fault will occur on the fire control panel.

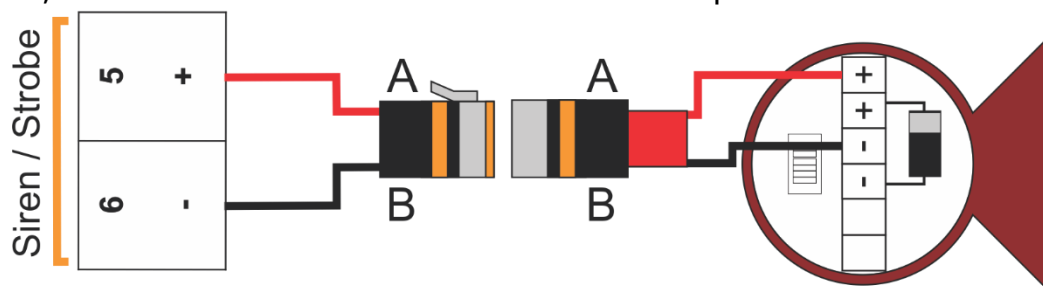

- Circuit 1 Alarm Circuit:** This circuit can be programmed for **ALARM ONLY** (operate siren/strobe) or **AUTOMATIC DISCHARGE** (discharges suppression system and operates siren/strobe). If detection is not used, the supplied end-of-line plugs (marked green) must be connected to the Circuit 1 Alarm output.

**Manual Actuator** (P/N FP-14053) can be connected together in quantities up to 30. If a manual actuator is being used for remote activation, it **must** be installed on Circuit 1 Alarm. The supplied end-of-line plugs (marked green) must be connected to the last manual actuator in the circuit.

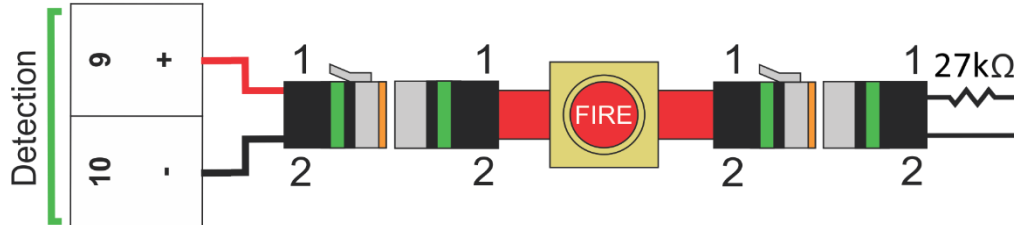

**Linear Heat Detection:** Linear Heat Detection can be installed in cut lengths with Deutsch plugs fitted. P-Clips must be installed at intervals of 50cm maximum to support the cable. The supplied End-of-line resistor is mounted in the Deutsch plug.

**Conventional Detector (Thermal / Smoke):** Conventional Detector (P/N FP-08920 Thermal / FP-94140 Smoke) can be connected together in quantities up to 30. A End-of-line resistor must be installed in the last detector in the circuit.

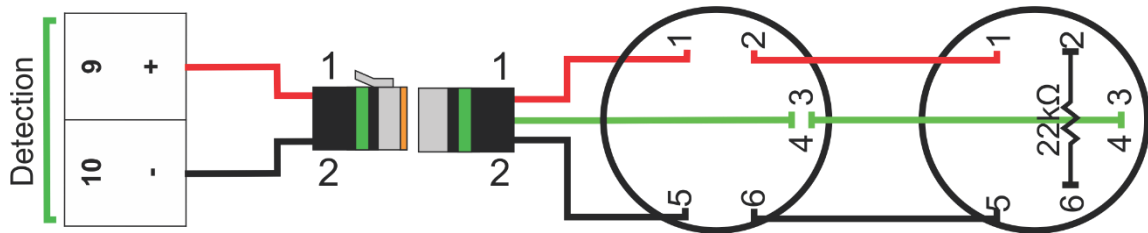

**Detection Not Used:** If detection is not used, the supplied end-of-line plugs (marked green) must be connected to the Circuit 1 Alarm output.

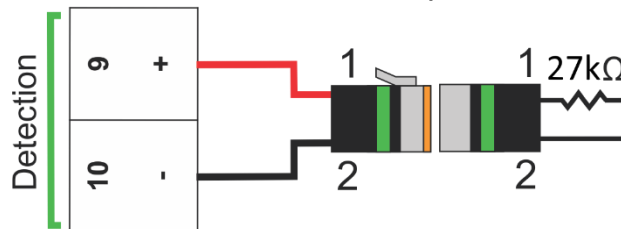

5. **Circuit 2 Alarm Circuit:** This circuit is **ALARM ONLY** and will only operate the siren/strobe. Connections for detection and manual actuators are the same as Circuit 1 Alarm. This is a monitored circuit so end-of-line plugs (marked green) must be connected.
6. **Discharge Circuit:** This circuit should remain disconnected until all other circuits are connected. The control panel **must not** be in an alarm/fault condition when the FirePro generators are connected, as this may cause an accidental discharge. A FirePro Test Module (P/N FP-08800) should be connected to take the control panel out of fault condition and for any commissioning.

**Connecting FirePro Generators:** If a single FirePro Generator is being installed, it can be

connected directly to the Discharge output on the control panel.

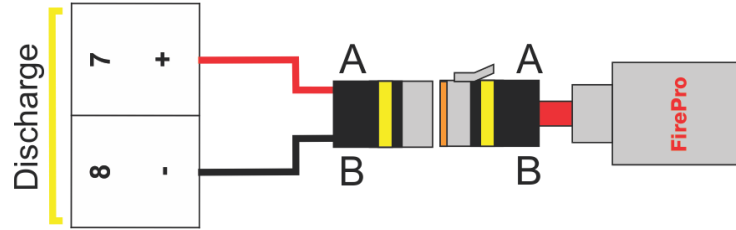

**Discharge Not Used:** If the discharge circuit is not used, the supplied end-of-line resistor (3k3Ω) must be connected to the Discharge output using the supplied deutsch plugs.

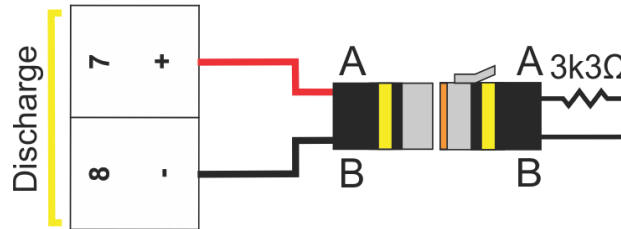

## 7 Wiring Diagram

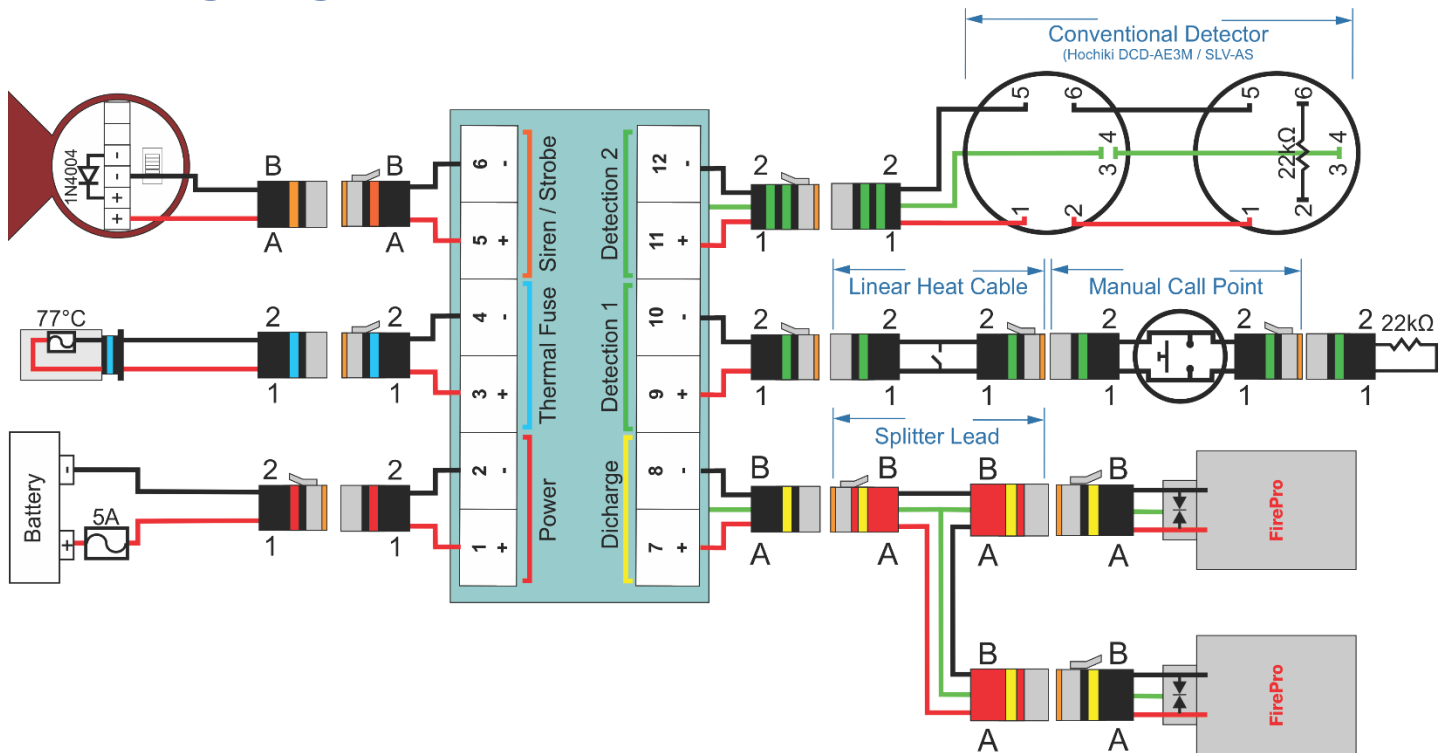

## 8 Programming

The FP-08451 Control Panel provides several programming options, allowing it to be adapted to site conditions. The 2-way DIP switches inside the panel next to the terminal block allow one of 4 modes to be selected. To access the DIP switches, open the panel enclosure.

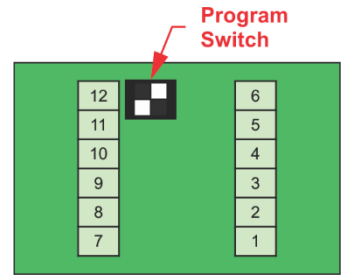

Switch 1	Mode	Switch 2	Mode
	<b>Standard Discharge</b> Power Applied for 2 seconds <b>DEFAULT</b>		<b>Manual Discharge</b> Detectors operate siren/strobe only
	<b>Extended Discharge</b> Power applied for 240 seconds		<b>Automatic Discharge</b> Detection on Circuit 1 Alarm will discharge system <b>DEFAULT</b>

**Note:** All programmed settings should be recorded in the logbook.

**Note:** If a Discharge Delay Module (P/N FP-08850) is installed, panel **must** be programmed for extended discharge.

## 9 Control Panel Indicators & Operation

### 9.1 LED Indicators

The FP-08451 Control Panel uses LED indicators to notify the operator of the condition of the control panel and each of the monitored circuits. If an LED is illuminated, it indicates the following:

Circuit	LED	Condition
Power	Green	Power supply is available
Circuit 1 Alarm	Red	System is in alarm condition
Circuit 2 Alarm	Red	System is in alarm condition
Fault	Yellow	System is in fault condition and needs servicing
Isolated	Yellow	System has been isolated using buttons on panel
Discharging	Red	System has initiated activation sequence
Agent Released	Red	Agent has been released and needs servicing

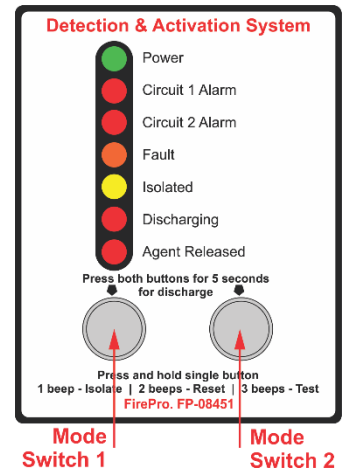

### 9.2 Isolate Function

To **isolate** the control panel, press and hold Mode Switch 1 until a 1 beep is heard and the "Isolated" LED is illuminated. To **restore** the control panel to normal operation, press Mode Switch 1 and ensure the "Isolated" LED turns off.

**Isolating disables automatic activation. Manual Activation will remain operational.**

When isolated, the control panel continues to monitor for alarm and fault, and show the alarm and fault indications, but will not operate the siren and the automatic discharge. When

isolated, any change in the detector status, will cause the panel sounder to operate for 1 second as an alert of the status change, but the panel will remain isolated. The isolate function will also silence the siren/strobe and the internal sounder but will not cancel the alarm or fault indication.

### 9.3 Reset Function

To reset the control panel, press and hold Mode Switch 1 until 2 beeps are heard. Following a reset, the control panel will automatically isolate. To restore the control panel to normal operation, press Mode Switch 1 and ensure the "Isolated" LED turns off. **Note:** The control panel **cannot** be reset if the activation sequence has been initiated. When the "Discharging" LED is no longer illuminated, the reset function will become available again.

### 9.4 Test Function

The control panel includes a test function, enabling the operator to ensure that the control panel is functioning correctly. To operate the test function, press and hold Mode Switch 1 until 3 beeps are heard. The test function will illuminate all LEDs on the control panel and operate the internal sounder and any external siren/strobes for 2 seconds, and then return the control panel to normal operation. The test function does not activate the suppression system. **Note:** If any LEDs or siren/strobes do not operate, contact your supplier.

### 9.5 Discharging the Fire System

To manually discharge the fire system, press and hold both Mode Switch 1 and Mode Switch 2 continuously for 5 seconds. This will immediately operate any installed siren/strobes and any shutdown relays, to warn any occupants. Manually discharging the fire system should only be performed during commissioning/servicing when the system has been appropriately isolated, or in case of fire.

### 9.6 Alarm Silence

To silence the internal sounder and any installed siren/strobes that have operated due to an alarm condition, press and hold Mode Switch 1 until a 1 beep is heard and the "Isolated" LED is illuminated. This will also override any installed shutdown relays and allow for operation of the equipment. **Note:** Equipment should not be operated until it has been rendered safe by the appropriate authority. The control panel will remain in an alarm/fault condition until serviced and reset.

## 10 Commissioning and Test Procedure

Commissioning should be performed when the fire control panel is not in an alarm/fault condition. **Note:** No personnel should be in the risk area until the fire system is fully isolated.

To ensure that the FirePro system will operate as designed, it should be inspected and serviced every 6 months, and yearly, in accordance with AS1851 and AS5062.

### Six Monthly Test Procedure:

- **Isolate the control panel** and disconnect the any installed FirePro aerosol generators. This will generate a fault on the fire control panel.
- **Connect FP-08800 Test Module(s)** to the "Discharge" output to the panel (marked yellow). Turn off the Isolate function. The Test Module should remain installed throughout the test procedure.

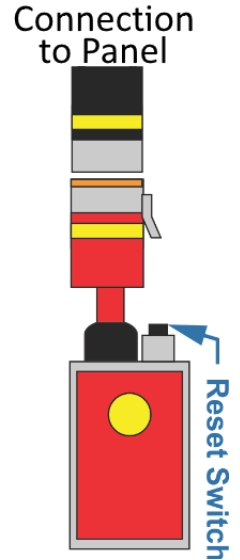

Testing of 4 FirePro Units

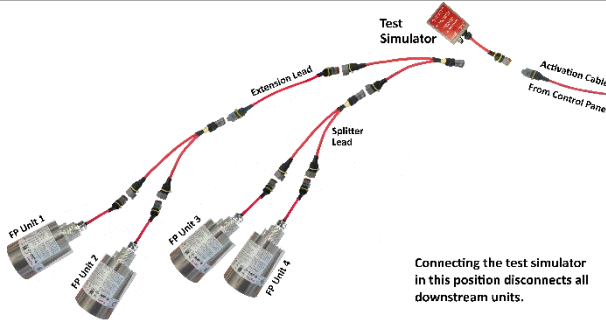

Testing of 2 FirePro Units

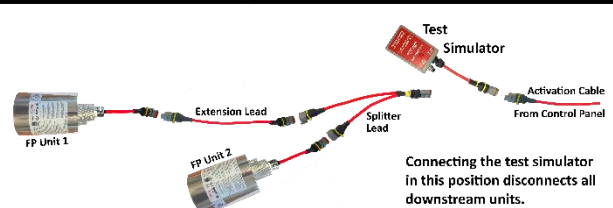

Alternate testing of 4 FirePro Units

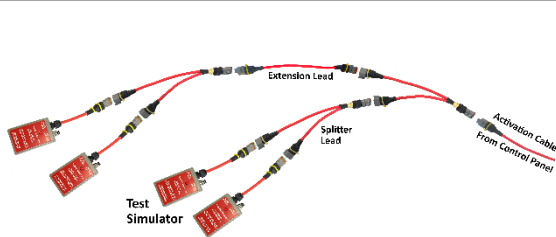

Alternate testing of 2 FirePro Units

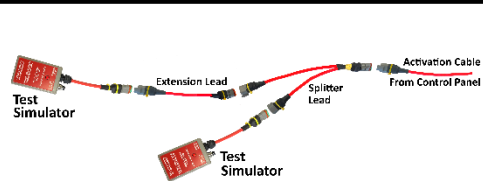

- **Control Panel and components:**

- Clean and remove dirt, grease or foreign material. Replace any parts that appear damaged or have been painted.
- Check all indicators are in normal position.

- **FirePro Aerosol Generators:**

- Inspect FirePro generators to ensure they are in good condition.
- Check mounting brackets are in good condition and secure.
- Check Dust Covers are in good condition – replace as necessary.
- Check FirePro Units are at predetermined aiming points.

- **Electrical System Inspection:**
  - Check Manual Actuators are secure, clean, undamaged.
  - Check that anti-tamper seals/pull pins are in place and secure.
  - Check all wiring, connection and supports are in intact, undamaged and in correct position.
- **Labels:**
  - Check manual release, system warning and instruction labels are in place and legible.
- **Test the fault monitoring** system by disconnecting and reconnecting all connected detection devices and the siren strobe circuit one at a time. Ensure the "Fault" LED indicator illuminates and the internal sounder is heard each time a circuit is disconnected.
- **Discharge Testing from Control Panel:**
  - Perform a manual discharge test by pressing and holding both mode switches on the panel continuously for 5 seconds.
  - Following activation, ensure the Test Module Red LED has operated.
  - Isolate the panel to silence alarm. Panel should now display a fault.
  - Reset Test Module. Panel should no longer be in fault condition.
  - Turn off the Isolate function.
- **Discharge Testing from External Devices:** Each detection and manual actuator device connected to must be tested individually.
  - Perform an automatic discharge test by activating the detectors or manual actuators.
  - Following the activation sequence ensure the Test Module Red LED has operated.
  - Isolate the panel to silence the alarm. The control panel should now display a fault.
  - Reset the Test Module.
  - Reset the control panel by pressing and holding a single mode switch until 2 beeps are heard. The control panel should no longer be in alarm/fault condition.
- **System control and indicating equipment.**
  - During discharge test, ensure operation of all installed siren/strobe(s).
  - During discharge test, ensure operation of all installed shutdown relays. This must shutdown any equipment specified in the risk assessment.
  - Test backup battery capacity. Replace every backup battery every 2 years.
- Disconnect the FP-08800 Test Module and reconnect all FirePro aerosol generators.
- Turn off the Isolation function. System is now operational.

### **Additional requirements for Commissioning of a System after Install or Discharge**

- **Design Survey** - check against the baseline data, for alterations, changes in use or operating environment, or other factors that could affect the performance of the fire protection system. (Annual)
- **Risk Assessment** – required to be prepared and reviewed every 5 years or after any incident. Review document to ensure system compliance. Check if document is current.



## 11 Servicing and Maintenance

Inspection and servicing of the installed fire system should occur in accordance with the relevant Australian Standards (i.e. AS1851 or AS5062). Any alterations to the risk area should be recorded and where necessary the risk assessment, design calculation and installed components must be revised to reflect the new operating conditions.

A logbook must be kept, recording all the relevant information from the installation and servicing. The logbook must contain the following:

### Content of logbook:

- General details
- Devices used
- Date and outcome each inspection
- Risk Assessment

### Appendices of Logbook:

- Schematic diagrams
- Photos of the original Installation
- Programming of the control panel
- Inspection reports

### 11.1 Daily Service Schedule

A daily inspection should be performed by the operator prior to operation of the equipment. If anything does not appear normal, the equipment should not be operated and the fire service provider alerted. The Daily Inspection should include:

- Visual inspection of the control panel and installed components. These should be accessible and free from debris, rust, or electrical faults.
- Visual inspection of the control panel to ensure normal functioning. When functioning normally the only indicator illuminated should be the "Power" indicator (green).
- Visual inspection of anti-tamper seals and travel pins, to ensure they are in place.

### 11.2 Semi-annual / Annual Service Schedule

Semi-annual and Annual servicing and maintenance **are to be undertaken only by accredited service technicians.** Any misuse of the FIP may result in an accidental discharge of the suppression system and is not covered by warranty.

Servicing should include a visual inspection of all the installed components to ensure they are in good condition, and that the relevant stream lengths and thermal clearances are observed as per the original design calculation and risk assessment.

Operation of the fire system should be tested as outlined in 8. Commissioning.

## 12 Troubleshooting

The FP-08451 Control Panel provides a comprehensive fault monitoring system that will detect any open-circuit in the Circuit 1 Alarm Output, Circuit 2 Alarm Output, Siren/Strobe Output, Discharge Output and Agent Released Input and any malfunctions of the control panel's internal components.

When in a fault condition, the control panel will operate the "Fault" LED indicator and operate the internal sounder. The control panel uses a coded sequence to indicate the type circuit to the operator. **Note:** To diagnose if a fault is internal or external, attempt to isolate the panel. If the control panel can be isolated, the fault is external. (see 9.2 Isolating the Control Panel).

### 12.1 Fault Indicators

A fault will be indicated if any monitored circuit connected to the panel is not complete. This could be caused by the devices connected or the wiring to each device. This will display as:

Internal Sounder	Fault LED	Fault
1 beep	On	Circuit 1 Alarm
2 beeps	On	Circuit 2 Alarm
3 beeps	On	Discharge Circuit
4 beeps	On	Siren/Strobe Circuit – Version 4 Panel Only

This will require inspection and testing of connections and installed components. End-of-line plugs should be plugged directly into the panel, to return it normal condition, and then used to systematically check along the effected circuit(s). If the fault persists, contact your supplier.

### 12.2 Panel is Unresponsive

If the panel has become unresponsive, check the incoming power supply. Panel will operate down to approx. 9vDC. If incoming voltage is above this contact supplier.

### 12.3 Internal Faults

An internal fault cannot be isolated and will display as:

Internal Sounder	Fault LED	Fault
Continuous, steady beep	On	Internal 5vDC Supply OR Watch Dog Circuit
Continuous, pulsing beep	On	Internal Microprocessor

Internal faults can be rectified by powering down the panel and powering up again. This will reset the system to normal conditions. If the fault persists, contact your supplier.

### 12.4 Agent Released Fault



Refer to 3.2 Agent Released Input. If the Agent Released LED is illuminated, this indicates a fault on the Agent Release input. Typical causes are that the thermal fuse coupling has operated or has been disconnected. To test if the thermal fuse coupling has operated, check with a multi-meter for a closed circuit. Thermal Fuse couplings are single use only. If the thermal fuse coupling has operated, it must be replaced (P/N FP-08825). If the thermal fuse coupling is functioning normally and the fault persists, contact your supplier.

## 13 RFI Environments

The control panel's circuit arrangement provides protection designed for the effects of electromagnetic emissions and prevent accidental discharges of the system. Shielded, fire rated cable (FP-09500) is **MUST** to be used throughout every installation to protect the fire system from electromagnetic emissions. Cables should be installed with appropriate clearances from any cables or equipment that may produce high levels of RF interference.

## 14 Safety Data Sheet (SDS) - FirePro

This is an **EXTRACT ONLY** from the full SDS. To view the full SDS go to [www.chemwatch.com.au](http://www.chemwatch.com.au).

	<p><b>HAZARDOUS SUBSTANCE. DANGEROUS GOODS.</b> <b>According to NOHSC Criteria, and ADG Code.</b></p> <p><b>CHEMWATCH HAZARD RATINGS</b></p> <table border="1"> <tr> <td>Flammability</td> <td>Low=1</td> <td>Moderate=2</td> <td>High=3</td> <td>Extreme=4</td> </tr> <tr> <td>Toxicity</td> <td>Low=1</td> <td>Moderate=2</td> <td>High=3</td> <td>Extreme=4</td> </tr> <tr> <td>Body Contact</td> <td>Low=1</td> <td>Moderate=2</td> <td>High=3</td> <td>Extreme=4</td> </tr> <tr> <td>Reactivity</td> <td>Low=1</td> <td>Moderate=2</td> <td>High=3</td> <td>Extreme=4</td> </tr> <tr> <td>Chronic</td> <td>Low=1</td> <td>Moderate=2</td> <td>High=3</td> <td>Extreme=4</td> </tr> </table> <p>SCALE: Min/Nil=0    Low=1    Moderate=2    High=3    Extreme=4</p> <div style="display: flex; justify-content: space-around;">   </div>	Flammability	Low=1	Moderate=2	High=3	Extreme=4	Toxicity	Low=1	Moderate=2	High=3	Extreme=4	Body Contact	Low=1	Moderate=2	High=3	Extreme=4	Reactivity	Low=1	Moderate=2	High=3	Extreme=4	Chronic	Low=1	Moderate=2	High=3	Extreme=4
Flammability	Low=1	Moderate=2	High=3	Extreme=4																						
Toxicity	Low=1	Moderate=2	High=3	Extreme=4																						
Body Contact	Low=1	Moderate=2	High=3	Extreme=4																						
Reactivity	Low=1	Moderate=2	High=3	Extreme=4																						
Chronic	Low=1	Moderate=2	High=3	Extreme=4																						
<p><b>PRODUCT NAME</b> CELANOVA FIREPRO</p> <p><b>PRODUCT USE</b> Fire extinguishing agent.</p>																										

### POISONS SCHEDULE - None

RISK	SAFETY
<ul style="list-style-type: none"> <li>Contact with combustible material may cause fire.</li> <li>Harmful if swallowed</li> <li>Irritating to eyes and skin.</li> <li>May cause SENSITISATION by skin contact.</li> <li>Harmful to aquatic organisms may cause long- adverse effects in the aquatic environment.</li> <li>Cumulative effects may result following exposure</li> <li>May produce discomfort of the respiratory. system*</li> <li>Possible respiratory sensitiser*.</li> <li>May possibly affect fertility* (limited evidence).</li> </ul>	<ul style="list-style-type: none"> <li>Keep away from combustible material</li> <li>Avoid exposure - obtain special instructions before use.</li> <li>To clean the floor and all objects contaminated by this material use water and detergent.</li> <li>Keep away from food drink and animal feeding stuffs.</li> <li>In case of contact with eyes rinse with plenty term of water and contact Doctor or Poisons Information Centre.</li> <li>If swallowed <b>IMMEDIATELY</b> contact Doctor or. Poisons Information Centre (show this container or label).</li> <li>This material and its container must be disposed of as hazardous waste.</li> </ul>

FIRST AID MEASURES	
<b>SWALLOWED</b>	<ul style="list-style-type: none"> <li>If swallowed do NOT induce vomiting.</li> <li>If vomiting occurs, lean patient forward or place on left side (head-down position, if possible) to maintain open airway and prevent aspiration. Observe the patient carefully.</li> <li>Never give liquid to a person showing signs of being sleepy or with reduced awareness.</li> <li>Give water to rinse out mouth, then provide liquid slowly and as much as casualty can comfortably drink.</li> <li>Seek medical advice.</li> </ul>
<b>EYE</b>	<ul style="list-style-type: none"> <li>If this product comes in contact with the eyes:</li> <li>Wash out immediately with fresh running water.</li> <li>Ensure complete irrigation of the eye.</li> <li>Seek medical attention without delay; if pain persists or recurs seek medical attention.</li> <li>Removal of contact lenses after an eye injury should only be undertaken by skilled personnel.</li> </ul>
<b>SKIN</b>	<ul style="list-style-type: none"> <li>If skin contact occurs:</li> <li>Immediately remove all contaminated clothing, including footwear.</li> <li>Flush skin and hair with running water (and soap if available).</li> <li>Seek medical attention in event of irritation.</li> </ul>
<b>INHALED</b>	<ul style="list-style-type: none"> <li>If dust is inhaled, remove from contaminated area.</li> <li>Encourage patient to blow nose to ensure clear passage of breathing.</li> <li>If irritation or discomfort persists, seek medical attention.</li> </ul>

## 15 Vehicle and Mobile Plant Installation Notes (AS5062)

For AS5062 vehicle installations, a risk assessment must be completed all equipment, and the design agreed upon by the installer and operators. The risk assessment should include identification of all fuel and ignition sources, and these must be considered in the system design.

### **AS 5062 requires:**

**Automatic Discharge:** The system shall be programmed for automatic discharge on alarm unless it is determined by the risk assessment why automatic discharge would be inappropriate.

**Equipment Shutdown:** As determined by the risk assessment, any equipment that may impede operation of the fire system must be shutdown prior to system discharge. This requires the installation of the FP-08860 Shutdown Relay Module.

**Secondary Power Supply:** In addition to the power supply requirements as per 3.1 Power Supply Input, AS5062 also requires a secondary power supply capable of operating the fire system for a minimum of 24 hours. This requires the installation of the Power Control Module, or the identification of a secondary power source in the equipment that will not be affected by any failure of the primary power supply.

**System Discharge Advice:** AS5062 requires independent notification of the suppression system discharged. This requires the installation of the FP-08825 Thermal Fuse Coupling.

**Manual Actuation:** Should manual actuators must be installed on Circuit 1 Alarm to allow for remote manual activation of the suppression system. This requires the installation of FP-14053 Manual Actuators and Circuit 1 Alarm to be programmed for automatic discharge.

## 16 Specifications

<b>General</b>	<b>Dimensions</b>	148L x 84W x 35D mm	
	<b>Material</b>	Diecast Aluminium, UV Tolerant	
	<b>Ingress Protection</b>	IP65	
	<b>Operating Temperature</b>	-40 to 85 degrees Celsius	
	<b>Fault Monitoring – External</b>	<ul style="list-style-type: none"> <li>- Circuit 1/2 Alarm – Open/Closed</li> <li>- Siren/Strobe – Open/Closed</li> <li>- Discharge – Open/Closed</li> </ul>	
	<b>Fault Monitoring – Internal</b>	<ul style="list-style-type: none"> <li>- Poly-switch fuse operated</li> <li>- Loss of internal 5V supply</li> <li>- Internal microprocessor malfunction</li> </ul>	
<b>Power Supply Input</b>	<b>Mains Operating Voltage</b>	12-30VDC	
	<b>Mains Operating Current</b>	20mA on 12V	23mA on 24V
	<b>Backup Power</b>	See FP-08870 / 08871 / 08872 manual	
<b>Detection Output</b> Circuit 1 Alarm & Circuit 2 Alarm	<b>No. of Detection Zones</b>	2	
	<b>Operating Voltage</b>	12-30VDC (same as main supply voltage)	
	<b>Detection End-of-line</b>	27kΩ / 22kΩ ½W Resistor	
	<b>Maximum Detectors per Zone</b>	<ul style="list-style-type: none"> <li>- 30 Conventional Detectors</li> <li>- 100m Linear Heat Detection</li> <li>- 30 Manual Actuators</li> </ul>	
	<b>Alarm Threshold</b>	3.6V Fault sensing threshold: 0.53V	
	<b>Compatible Detectors</b>	Hochiki SLV-AS Smoke Detector Hochiki DCD-AE3M Thermal Detector 14053 Manual Actuator 09510 180°C Linear Heat Detection	
<b>Discharge Output</b>	<b>Discharge Output Current</b>	1.5A at 12vDC	1.5A at 24vDC
	<b>Discharge End-of-line</b>	3K3Ω ½W Resistor	
	<b>Max FirePro Units</b>	2 at 12vDC	4 at 24vDC
	<b>Standard Discharge Delay</b>	5 seconds from automatic/manual activation	
	<b>Max Discharge Delay Modules</b>	2 DDM's at 12vDC	4 DDM's at 24vDC
	<b>Max FirePro units using DDM's</b>	6 at 12vDC	20 at 24vDC
<b>Siren/Strobe Output</b>	<b>Siren/Strobe Output Current</b>	Max 0.5A	
	<b>Siren/Strobe Output Protection</b>	0.5A poly-switch resettable fuse	
	<b>Siren/Strobe End-of-line</b>	1N4004 Diode	
	<b>Max Siren/Strobes</b>	5	
	<b>Compatible Siren/Strobes</b>	Banshee Sounder Strobe	
	<b>Max Siren Shutdown Modules</b>	2 at 12vDC	4 at 24vDC
<b>Agent Released Input</b>	<b>Input Type</b>	Thermal Switch, NC, Latching, Non-resettable	
	<b>Operation</b>	Thermal Event >80°C	

BANSHEE multi-tone sounder/strobe - suitable for internal or external locations.



Specifications		
Voltage:	9 – 30vDC	
Current:	12v - Max 60mA	24v - Max 39mA
Sound Output:	101dB(A)	
Beacon:	0.7j	
Flash Rate:	60/min (1Hz)	
Temperature:	-20 C to +55 C	
IP Rating:	FP-08940 – IP 45	FP-08941 – IP 66



## 1 General Operations

1.1 FirePro Test Simulator used with the following:

<b>Sigma XT</b>	Aust. Standard Fire Panels	<b>FP-08917</b>	Local Application System (Check Volatge Required)
<b>FP-08450</b>	Marine Control Panel		
<b>FP-08451</b>	Vehicle AS 5062 Panel.	<b>FP-C2</b>	Sub-Panel or local protection solutions
<b>FP-08100</b>	NON-Monitored Control Panel (Check Volatge Required)	<b>FP-C4</b>	Local Application System (Check Volatge Required)

- 1.2 **Battery Power Supply & Indicators** - The simulator has a single indicator light. The unit has a latching indicator – will stay illuminated until reset.
- 1.3 Pressing **the Test/Reset button** will reset the simulator, and will illuminate the light to show that the unit and internal battery is operating properly. The simulator should be reset after each test is performed.
- 1.4 Replacing **the battery** – The simulator is operated by a standard 9V alkaline battery. To replace the battery remove the back plate. Battery should be replaced on average every 2 years. FP-08800 (Version 4) has a battery test facility – the test lamp will not operate once the internal battery voltage is below 7.5v – this will indicte when to replace this battery.



## 2 Specifications

<b>Power Supply</b>	<b>9v Alkaline Battery</b>
<b>Low Voltage Battery Indicator</b>	<b>7.5v – Test Lamp will not operate (V4 Only)</b>
<b>Resistance of Test Simulator</b>	<b>2.5 Ω</b>

<b>SPECIFIC CONTROL PANELS</b>	<b>MINIMUM SUPPLY VOLTAGE</b>		
<b>FP-08917</b> - Local Application System	<b>6v - 1 FP Unit</b>	<b>12v - 2 FP Units</b>	<b>24v - 4 FP Units</b>
<b>FP-08100</b> – Non Monitored Control Panel	<b>6v - 1 FP Unit</b>	<b>12v - 2 FP Units</b>	<b>24v - 4 FP Units</b>
<b>FP-C4</b> - Local Application System	<b>6v - 1 FP Unit</b>	<b>12v - 2 FP Units</b>	<b>24v - 4 FP Units</b>

## 3 Servicing & Maintenance

The FirePro Suppression system should be serviced at least every 6 months in accordance with AS 1851, more often in aggressive environments. Periodic visual inspections of the installed system must also be conducted by the operators to ensure all installed parts are free from debris, rust, or electrical faults. Servicing **must only be undertaken by accredited service technicians.**

**NO PERSONNEL SHOULD BE IN THE RISK AREA DURING TESTING UNTIL THE FIREPRO UNITS ARE DISCONNECTED AND TEST MODULES IN PLACE**

### Servicing and Maintenance Procedure

- 3.1 Specific Testing procedures are identified in each system manual.
- 3.2 Disconnect the FirePro activation circuit (Yellow) at the panel, and connect the FirePro simulator.
- 3.3 Visually inspect all installed FirePro Generators, cable, connections, detection devices and siren/strobes. Look for any signs of damage or wear and replace as necessary.
- 3.4 Activate the system – after ensuring the FirePro Simulator is connected. Simulator stay illuminated until the reset button on the simulator is pressed.
- 3.5 Reconnect the FirePro activation circuit.



**Note:** the FirePro Simulator stay illuminated until the reset button on the simulator is pressed.

## Testing of 2 FirePro Units

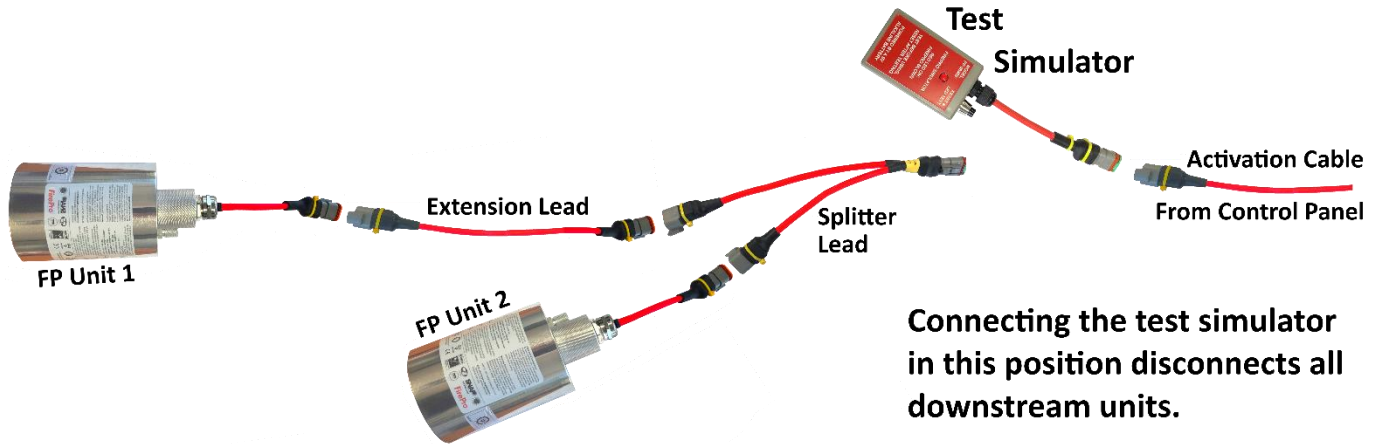

Connecting the test simulator in this position disconnects all downstream units.

## Alternate testing of 2 FirePro Units

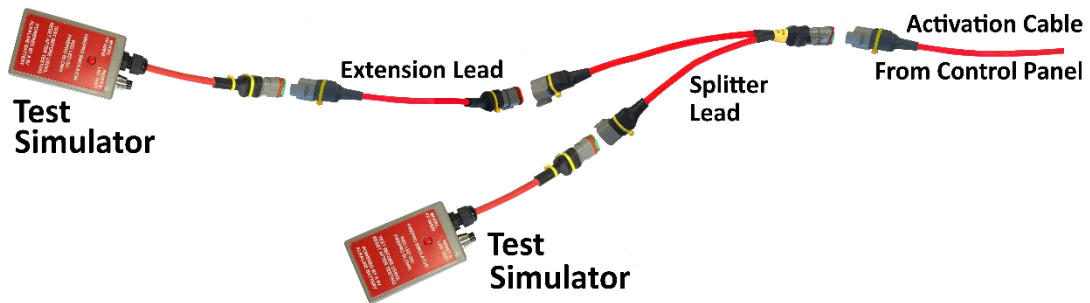



## Testing of 4 FirePro Units

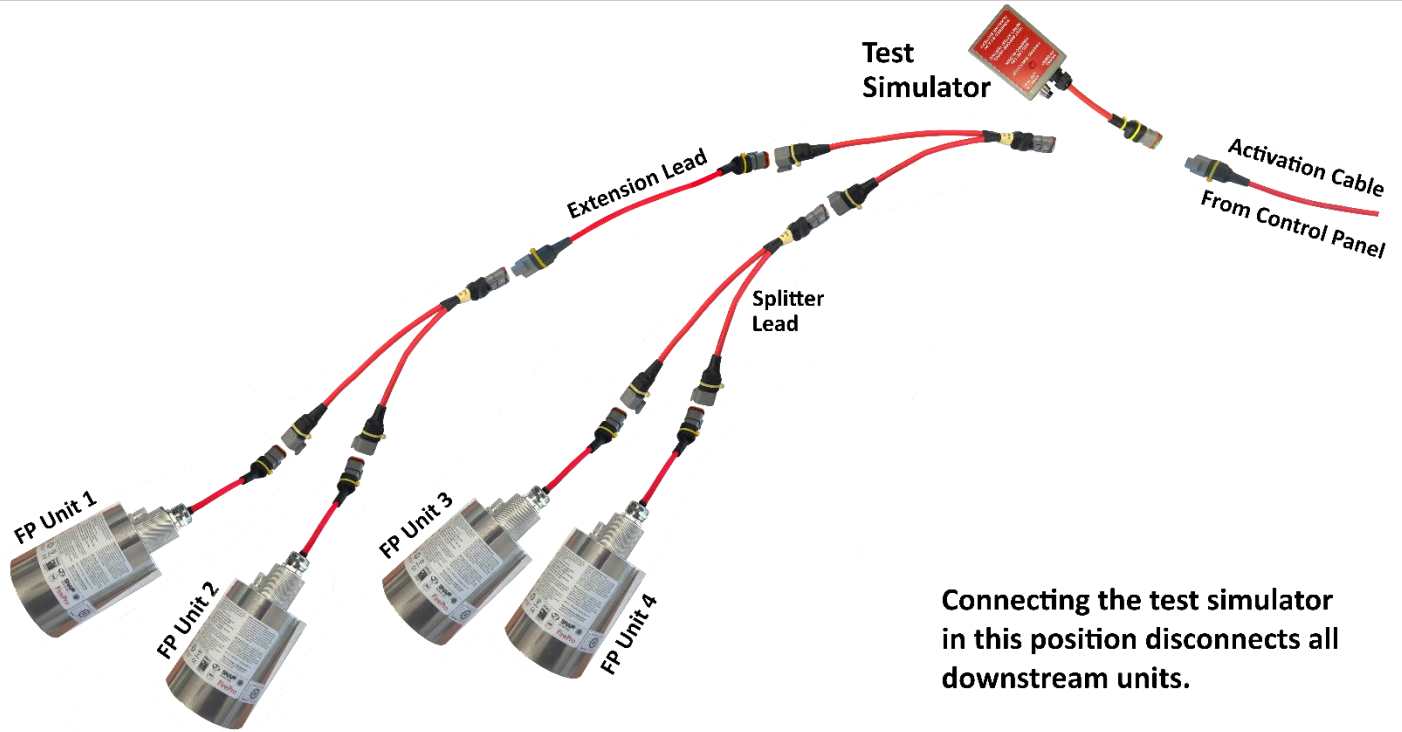

Connecting the test simulator in this position disconnects all downstream units.

## Alternate testing of 4 FirePro Units

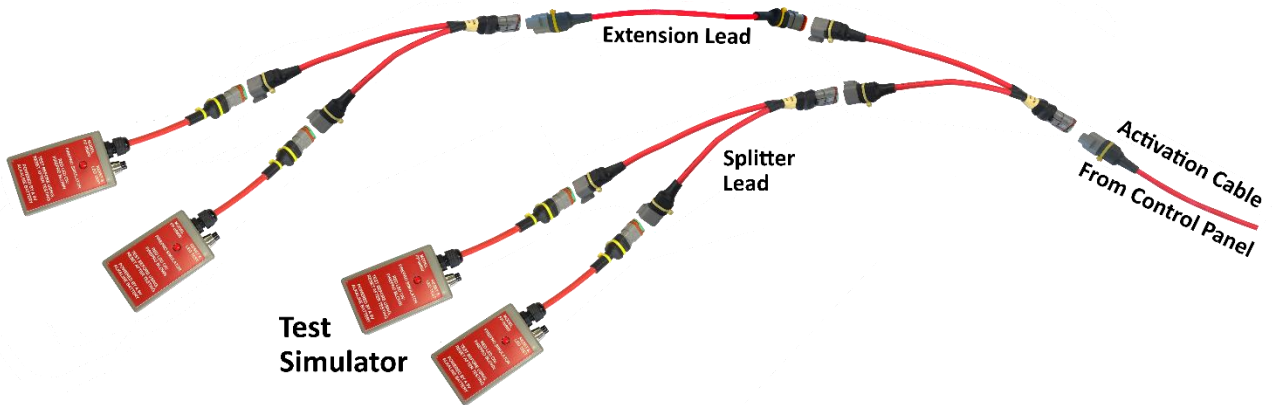



## 1 Introduction

The FirePro FP-08451 Fire Control Panel is a combined detection and extinguishant system and is certified for vehicle and mobile plant installations (AS5062). The thermal fuse is required by AS-5062 as an indicator that the system has activated. It has no ability to activate the system.

**SINGLE USE ONLY – CANNOT BE RESET**



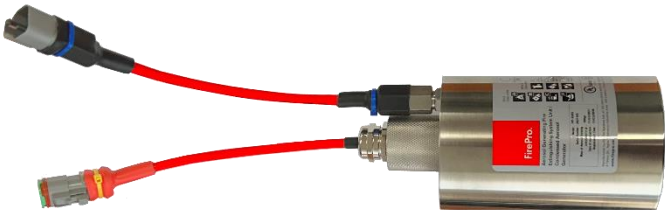

## 2 Thermal Fuse Connection -

The thermal fuse should be mounted on the most convenient – or closet FirePro unit to the Control Panel. Only one thermal fuse is required in each system. This thermal fuse is mounted in a stainless steel enclosure, and this is rated to IP65. It designed for use at temperatures between -5°C (+/- 3) and +40°C (+/-2) and with a maximum relative humidity of 95%.

### 2.1 For FirePro Generators FP-0040S to FP-0500S range

<p><b>1</b></p>	<p>Remove cap from the thermal port.</p>	
<p><b>2</b></p>	<p>Install the Thermal Fuse assembly. FP-08825.</p> <p>Connect cable to the SYSTEM ACTIVATED circuit at the FIP.</p>	

## 2.2 For FirePro Generators FP-1200S to FP-5700S range for products after 2023

<p><b>1</b></p>	<p>Remove the Thermal Connector Cover.</p>		
<p><b>2</b></p>	<p>Install the Thermal Sensor FP-08828</p>		 <p>Thermal Sensor</p>
<p><b>3</b></p>	<p>Install the Thermal Fuse Assembly FP-08825</p> <p>Connect cable to the SYSTEM ACTIVATED circuit at the FIP.</p>		 <p>Thermal Fuse Assembly</p>

## 2.3 For FirePro Generators FP-1200S to FP-5700S range for products prior 2023

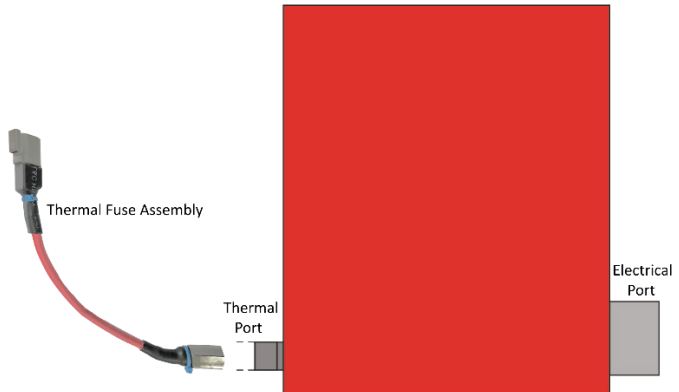
<p><b>1</b></p>	<p>Remove cap from the thermal port.</p>	 <p>Thermal Fuse Assembly</p> <p>Thermal Port</p> <p>Electrical Port</p>	
<p><b>2</b></p>	<p>Install the thermal fuse assembly.</p> <p>Connect cable to the SYSTEM ACTIVATED circuit at the FIP.</p>		



## Contents

1	Introduction .....	2
2	Components List.....	2
3	Design Considerations.....	2
4	Installation .....	4
5	Wiring Diagram .....	4
6	Programming.....	5
7	Commissioning .....	7
8	Servicing and Maintenance.....	7
9	Operation.....	7
10	Troubleshooting.....	8
11	Specifications .....	8

## 1 Introduction

### 1.1 General Information

The FP-08860 Siren & Shutdown Module provides a modular shutdown relay to be installed in conjunction with the FP-08450 or FP-08451 Fire Control Panel. The Siren & Shutdown Module allows for the fire control panel to shutdown or activate any necessary equipment when in an alarm condition. The Siren & Shutdown Module provides a volt free contact that can operate appropriately rated slave relays.

The module also includes a delay timer for the relay that can be set to suit for vehicle or site specific conditions.

### 1.2 AS5062 Vehicle and Mobile Plant Installations

Used where the risk assessment requires the engine to be shut down on alarm. Multiple Siren & Shutdown Modules can be connected together where multiple relay outputs are required in an install.

### 1.3 External Notification and Networking

Where equipment or a site requires networking to other equipment (e.g. a PLC) the shutdown relay module can be used to advise when the fire control panel is in an alarm condition.

### 1.4 Reset of Relay following Activation

The module takes power from the Siren output on the Panel so if Siren is silenced from the panel is reset then relay will go back to normal state.

## 2 Components List



**FP-08860**  
**Siren & Shutdown Module**  
Operates Siren and volt free contact  
for shutdown

1x DP-2010 - Deutsch Plug 2 Pin Female, c/w heatshrink

1x DP-3010 - Deutsch Plug 3 Pin Female, c/w heatshrink

## 3 Design Considerations

### 3.1 Siren/Strobes Output

In a typical install, the maximum number of supported sirens/strobes that can be installed is limited by the control panel, check manual for limits. When installed, Siren/Strobes are to be visible and audible at all points around the risk area.

The siren/strobe output is a monitored circuit. Where a siren/strobe is not installed the supplied end-of-line diode (1N4004) **must** be installed on the siren output, otherwise the fire control panel will display a fault and the relay will not operate. If multiple modules are used siren/strobes should be connected to the last installed module in the circuit.

### 3.2 Relay Output

In a typical install, the maximum number of supported shutdown modules that can be installed is 5. However, these can be connected to additional slave relays where required.

Where multiple modules are used, the modules are to be connected using the siren/strobe output (marked orange) as below. There are no limitations to the individual programming of a module when multiple modules are connected together.

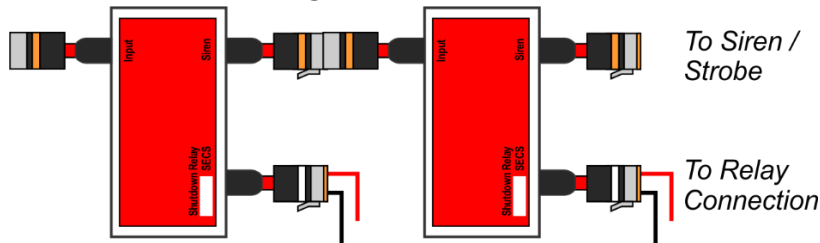

Direct connections of electrical equipment to the shutdown relay **must not** exceed the rating of the relay (see 11. Specifications), as this may damage the module and fire control panel.

The relay may be set to normally open or normally closed (see 6. Programming) to suit equipment or site specific conditions.

### 3.3 Cabling Requirements

Cable Requirements - All cabling in the FirePro Installation **MUST** be done using 0.75mm shielded Fire Rated Cable. Care taken to ensure that all cables are isolated, and that RF shielding on cable is stripped back to ensure that there is not accidental grounding. Cables are colour coded for easy identification.

Extension Leads - Deutsch Plugs must be used to ensure water-proof connections are made throughout the installation.

Colour	Circuit
Red	Power Supply
Yellow 1	Activation
Yellow 2	Activation Delayed
Green 1	Detection 1
Green 2	Detection 2
Orange	Siren/Strobe
White	Relay Output

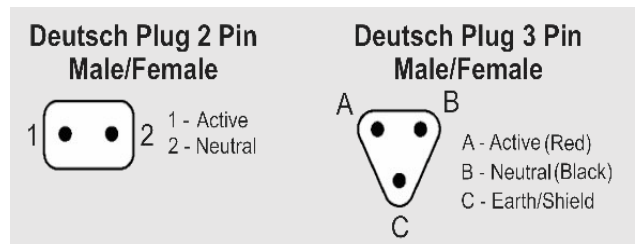

### 3.4 Mounting

For correct installation, the Siren & Shutdown Module must be mounted by four bolts or screws through the mounting holes in the flange on both sides of the Module. **No penetrations are to be made through the casing of the panel.**

The Siren & Shutdown Module enclosure is rated IP65, so should be installed in a convenient location, away from where it may be affected by large amounts of water. The module does not need to be installed adjacent to the fire control panel.

## 4 Installation

1. The input cable from the FIP may be connected at any time. However, the FIP will remain in fault condition and the relay will not operate until all other steps are completed.
2. **If siren/strobe installed**, use an extension lead to connect the siren strobe to the "Siren" output on the module (marked orange). The supplied end-of-line diode should be installed in the unused positive/negative terminals of the last siren/strobe in the circuit. The diode is polarised, so the positive lead of the diode (marked with a grey band) should be terminated in the positive terminal of the siren/strobe, otherwise a fault will occur on the fire control panel.
3. **If not using a siren/strobe**, the end-of-line diode should be terminated into the supplied 3 pin Deutsch plug (note polarisation) and then connected to the "Siren" output on the module (marked orange). The end-of-line plug should then be covered in heat shrink, and the heat shrink crimped, to avoid ingress of water into the circuit.
4. The shutdown relay can now be connected. The shutdown relay connection is not polarised and should be terminated using the supplied 2 pin Deutsch plug. The Siren/Strobe or end-of-line diode **must** be connected for the relay to operate.
5. The Siren & Shutdown Module can be programmed to suit vehicle or site specific requirements.

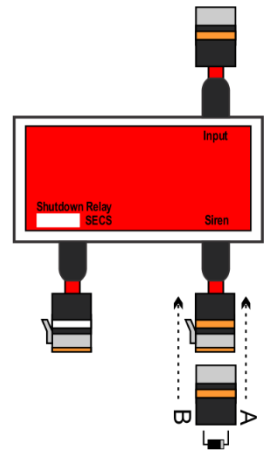

## 5 Wiring Diagram

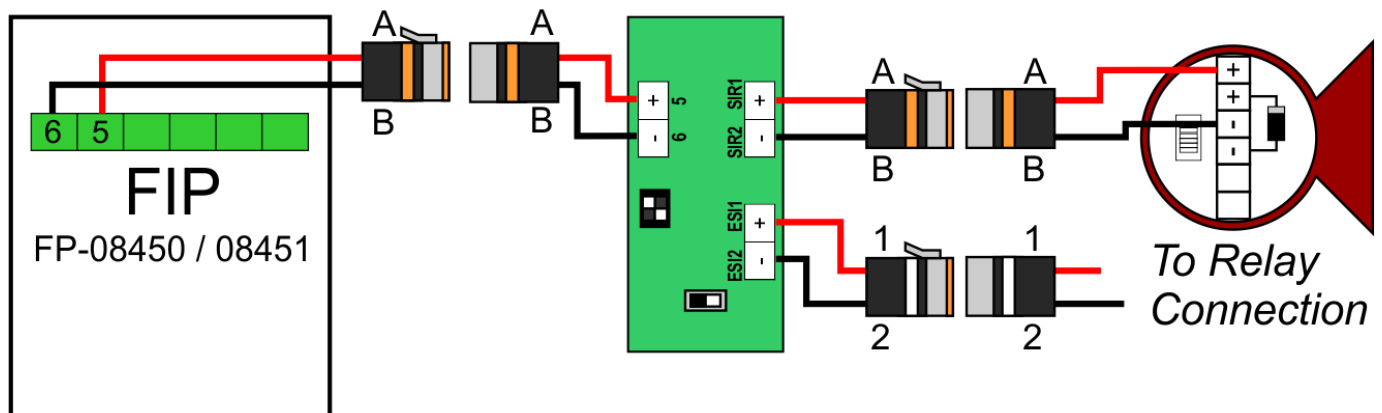

## 6 Programming

### 6.1 Programming Shutdown Delay - Module V3

The Delay Timer allows for the activation of the relay to be delayed after the panel has entered an alarm state. Where multiple modules are used, each module may have separate programming. The Siren/Strobe or end-of-line diode **must** be connected for the relay to operate.

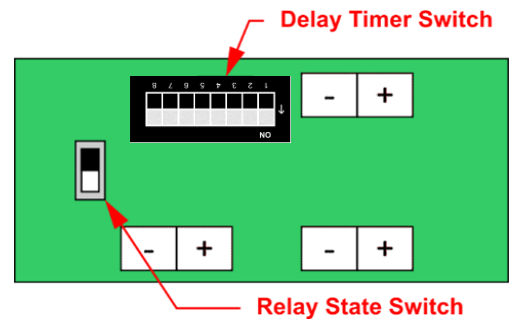

Delay Timer Switch								
Switch Number	1	2	3	4	5	6	7	8
Delay Value	1 sec	2 sec	4 sec	8 sec	16 sec	32 sec	64 sec	128 sec

The delay time is programmed by setting the required switches to the "OFF" position. If multiple switches are used, the delay values are added together, allowing for any delay time between 1 to 255 seconds to be programmed.

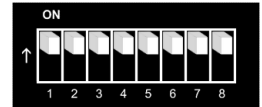

Example of common delay times:

Delay Time	Switch Positions	Delay Time	Switch Positions
2 seconds		60 seconds	
15 seconds		90 seconds	
20 seconds		120 seconds	
30 seconds		240 seconds	

Settings must be recorded in logbook and on in the space provided on the front of the module.

### Programming Relay State - Module Version 3

The Relay State Switch allows for the relay to be set to either normally open or normally closed. Where multiple modules are used, each module may have separate programming.

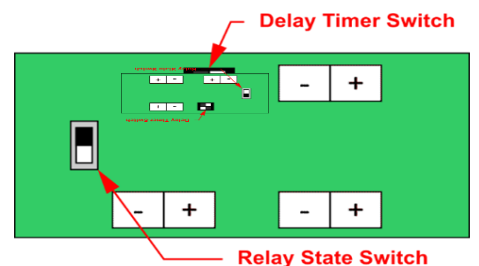

Relay State Switch	Mode
	ON <b>NORMALLY OPEN</b>

Relay State Switch	Mode
	OFF <b>NORMALLY CLOSED</b>



## 6.2 Programming Module Version 1 - 2.1

The Delay Timer Switch allows for the activation of the relay to be delayed for a period the fire control panel has entered an alarm state.

The Relay State Switch allows for the relay to be set to either normally open or normally closed.

There are no limitations to the individual programming of a module, when multiple modules are connected together.

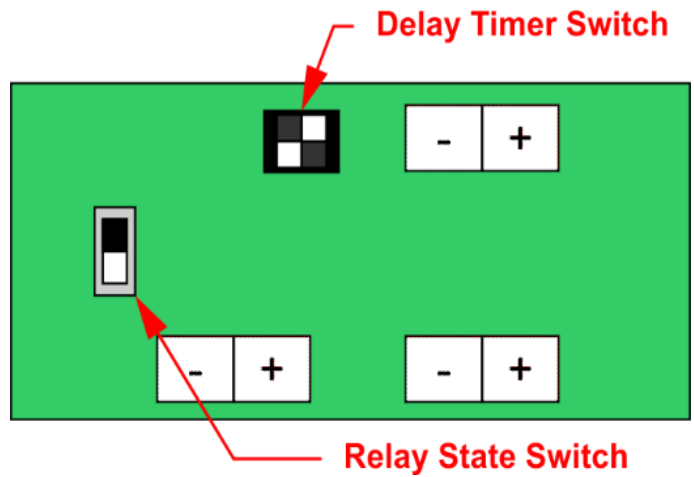

**The Siren/Strobe or end-of-line diode must be connected for the relay to operate.**

Delay Timer Switch	Mode
	Switch 1 – ON Switch 2 - ON <b>DELAY Set to 1 second</b>
	Switch 1 – OFF Switch 2 - ON <b>DELAY Set to 5 seconds</b>
	Switch 1 – ON Switch 2 - OFF <b>DELAY Set to 10 seconds</b>
	Switch 1 – OFF Switch 2 - OFF <b>DELAY Set to 15 seconds</b>

Relay State Switch	Mode
	Switch - ON <b>Relay set to NORMALLY OPEN</b>
	Switch - OFF <b>Relay set to NORMALLY CLOSED</b>

Settings must be recorded in logbook and on in the space provided on the front of the module.

## 7 Commissioning

Commissioning should be performed when the siren and shutdown relays are connected, and fire control panel is not in an alarm/fault condition.

1. Isolate and disconnect the any installed FirePro aerosol generators. This should generate a fault on the fire control panel.
2. Connect a FirePro FP-08800 Universal Test Lamp.
3. Perform an activation test, by pressing and holding the buttons on the fire control panel or through the detection circuits.
4. Ensure that any sirens or strobes connected to the system are operational.
5. Test the shutdown relay by testing the state of the contacts or attempting to turn on the related equipment.
6. Disconnect the FirePro FP-08800 Universal Test Lamp and reconnect all installed FirePro aerosol generators.

## 8 Servicing and Maintenance

Inspection and servicing of the installed fire system should occur in accordance with the relevant Australian Standards. This should include a visual inspection of the enclosure to ensure the seals are intact.

Operation of any installed sirens/strobes and connected relays should be tested as outlined.

## 9 Operation

The Siren & Shutdown Module operates when the fire control panel in is an alarm condition or the fire system has been manually activated. When activated, the siren will operate immediately, and initiate the programmed time delay for the relay. When the time delay is completed, the relay will operate and shutdown any connected equipment.

**Note: The siren and relay will remain active until the panel is isolated and reset.**

## 10 Troubleshooting

Problem	Possible Cause	Solution
Siren/strobe not operating	Reversed or poor connection to module or to siren/strobe	Check connection and polarity of any extension cables. Ensure power is reaching siren by measuring voltage when in normal and alarm condition.
Relay not operating	Reversed or poor connection to module or to siren/strobe OR Reversed or poor connection to End-of-line diode	Check connection and polarity of any extension cables and End-of-line diode.
Equipment not operating	Incorrect setting for relay OR System has activated	Check if equipment requires N/O or N/C Check condition of fire system
Fault displayed on fire control panel (3 Beeps)	Reversed or poor connection to End-of-line diode OR Number of installed modules exceeds limit OR Power supply below 9.0vDC	Check connection and polarity of any extension cables and End-of-line diode.

For additional assistance contact your supplier.

## 11 Specifications

<b>Dimensions</b>	140L x 65W x 30D
<b>Enclosure material</b>	Die Cast Aluminium
<b>Operating voltage</b>	12-30VDC
<b>Output - Siren</b>	Siren max 0.5A at 12 or 24VDC
<b>Output - Relay</b>	Relay max 30vDC 2A
<b>Discharge end-of- line</b>	Siren Only 1N4004 diode
<b>Fault-sensing</b>	Siren Only - wiring open-circuit
<b>Operating Temp.</b>	40 to 85 degrees Celsius
<b>Ingress Protection</b>	IP65
<b>Max no. of Modules</b>	5



Reinventing Fire Suppression

# Power Control Module Model 08872 Model 08873

Rev 3.0



**Model FP-08872**



**Model FP-08873**



## Contents

- 1 Introduction .....2
- 2 Components List.....2
- 3 Design Considerations.....3
  - 3.1 Power Supply Input .....3
  - 3.2 System Limitations.....3
  - 3.3 Mounting.....3
  - 3.4 Cabling Requirements .....3
  - 3.5 Operation.....4
- 4 Installation.....4
- 5 Commissioning .....5
- 6 Servicing and Maintenance.....5
  - 6.1 Replacing the Internal Batteries.....5
- 7 Power Control Module Version II – Auto Voltage Selection .....6
- 8 Power Control Module Version I – Manual Voltage Selection.....7

# 1 Introduction

The FP-08872 or FP-08873 Power Control Module provides a plug-in, supplementary power supply to be installed in conjunction with the FP-08450 or FP-08451 Fire Control Panel. The Power Control Module provides continuous power to the FirePro fire control panel, for a period of 24 hours (as per AS5062), in the event the main power supply fails.

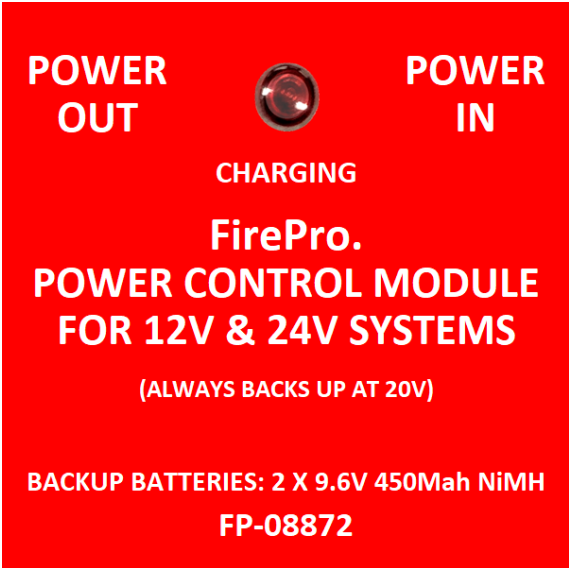

There are 2 versions

 <p><b>POWER OUT</b>      <b>POWER IN</b></p> <p>CHARGING</p> <p><b>FirePro.</b> <b>POWER CONTROL MODULE</b> <b>FOR 12V &amp; 24V SYSTEMS</b></p> <p>(ALWAYS BACKS UP AT 20V)</p> <p>BACKUP BATTERIES: 2 X 9.6V 450Mah NiMH</p> <p><b>FP-08872</b></p> <p><b>Version II</b></p> <p>This unit automatically selects incoming voltage</p>	 <p><b>POWER OUT</b>      <b>POWER IN</b></p> <p>CHARGING</p> <p><b>FirePro.</b> <b>POWER CONTROL MODULE</b> <b>FOR 12V &amp; 24V SYSTEMS</b></p> <p>(SET BY INTERNAL SLIDE SWITCH)</p> <p>BACKUP BATTERIES: 2 X 9.6V 450mAH NiMH</p> <p><b>FP-08872</b></p> <p><b>Version I</b></p> <p>Incoming Voltage to be selected by Internal Switch</p>
--	--

There are slight differences in the operation of the module, details are provided in the manual. Batteries are the same for each module.

**AS5062 Vehicle and Mobile Plant Installations required Battery backup** unless there are two separate power supplies capable of operating the fire system for 24 hours.

# 2 Components List

	<p>FP-08872 Power Control Module</p> <p>Power Control Module, 12 - 1x DP-2200</p> <p>24vDC, NiMh, two side entry</p>	<p>Deutsch Plug</p> <p>Pin Male/Female</p> <p>c/w heatshrink</p>
	<p>FP-08873 Power Control Module</p> <p>Power Control Module, 12 - 1x DP-2200</p> <p>24vDC, NiMh, one side entry</p>	<p>Deutsch Plug</p> <p>2 Pin Male/Female,</p> <p>c/w heatshrink</p>
	<p>FP-18157 Replacement Backup Battery</p> <p>9.6vDC, 450mAh NiMH</p>	

### 3 Design Considerations

#### 3.1 Power Supply Input

The FirePro Power Control Module is a multi-voltage backup power supply, able to be configured to operate on either 12-volt DC or 24-volt DC. The configuration of the Power Control Module should be based on the available power supply, as the main power supply input **MUST** have the same voltage as the selected operating voltage of the Power Control Module. The main power supply should be connected directly to the vehicle battery – NOT through the vehicle’s fuse block. This will ensure continuous power to the FIP. The connection to the vehicle battery must be done using a FP-14016 Battery lead, with an inline fuse installed.

#### 3.2 System Limitations

Due to the capacity of the backup batteries, the FP-08872/73 Power Control Module has limitations on the number and type of components that can be connected while still providing 24hr backup. Each installed system will be designed around these limitations, and your supplier must be consulted prior to adding any additional devices or modules to the system. The maximum number of FirePro generators able to be discharged is limited by the voltage of the main power supply. That is:

Voltage 12vDC Max = 2 Units	Voltage 24vDC Max = 4 Units
-----------------------------	-----------------------------

#### 3.3 Mounting

For correct installation, the Power Control Module must be mounted by bolts or screws through the mounting holes in the flange on both sides of the Module. **No penetrations are to be made through the casing of the panel.**

The Power Control Module enclosure is rated IP65, so should be installed in a convenient location, away from where it may be affected by large amounts of water. The module does not need to be installed adjacent to the fire control panel.

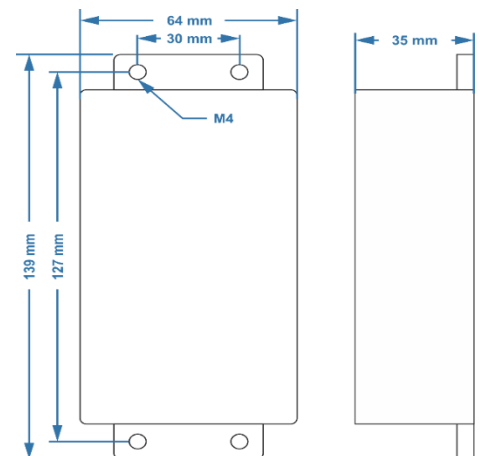

#### 3.4 Cabling Requirements

When constructing extension leads the supplied Deutsch Plugs must be used to ensure waterproof connections are made throughout the installation.

Use Heat Shrink to seal the back of the plug.

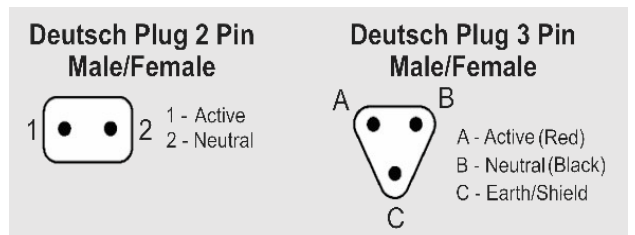

Cables are colour coded for easy identification. When installing system, cables should be only connected to the correctly coded cable. Colour Coding for cables is as follows:

Colour	Circuit
Red	Power Supply
Yellow 1	Activation
Yellow 2	Activation Delayed
Green 1	Detection 1
Green 2	Detection 2
Blue	Discharge Advice
Orange	Siren/Strobe
White	Relay Output

### 3.5 Operation

The Power Control Module operates when both a Main Power supply and the internal backup battery are connected. Should the main supply fail or drop below operating voltage, the module automatically switches the power supply to the internal batteries. When the Power Control Module has been connected the "Charging" LED will flash continuously to indicate that the main power supply is providing good supply.

## 4 Installation

1. The output cable to the FIP should remain disconnected until all other steps are completed.
2. **When supplied, the internal batteries are disconnected.** Before connecting the main power supply, open the Power Control Module and connect both internal batteries to the power terminals.
3. If **Version I module** Check the voltage of the available main supply, and using the internal switch select the appropriate operating voltage for the module. Version II is auto sensing so this step not required.

**Note:** Selecting an incorrect voltage will cause the internal batteries to not fully charge and may cause damage to the module.

4. With the main supply voltage selected, it is now safe to connect the main power supply.
5. Using the FP-14016 Battery Lead, connect the Power Control Module directly to the vehicle battery and plug the Battery Lead into the "Power In" Input. If the main power supply voltage is correct, the "Charging" LED indicator will illuminate and flash.
6. If the LED indicator is illuminated and flashing, the Power Control Module can be closed and the FIP power cable can be connected to the "Power Out" output, marked red.

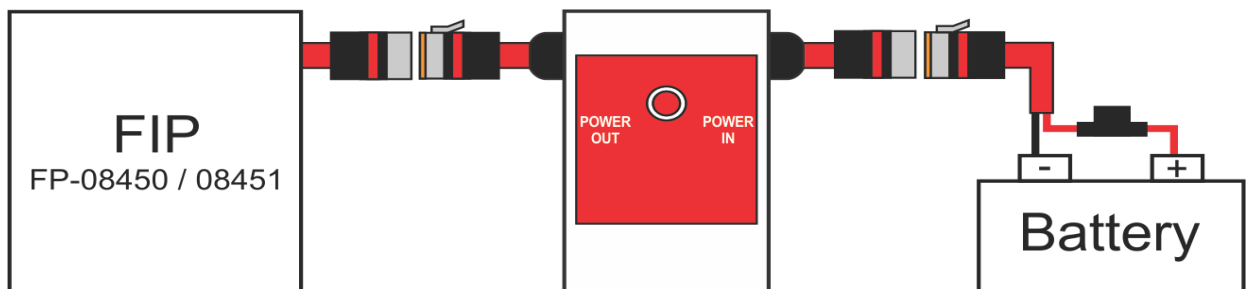
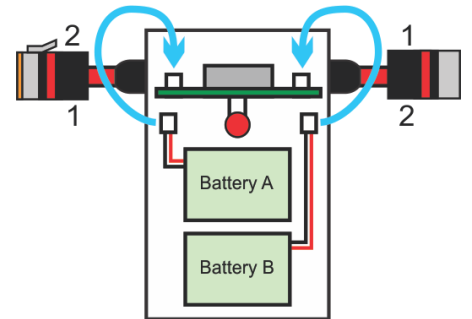

**Note:** Any connections must observe polarisation as shown in wiring diagram. Incorrect connections will not provide power and may damage the module or FIP.

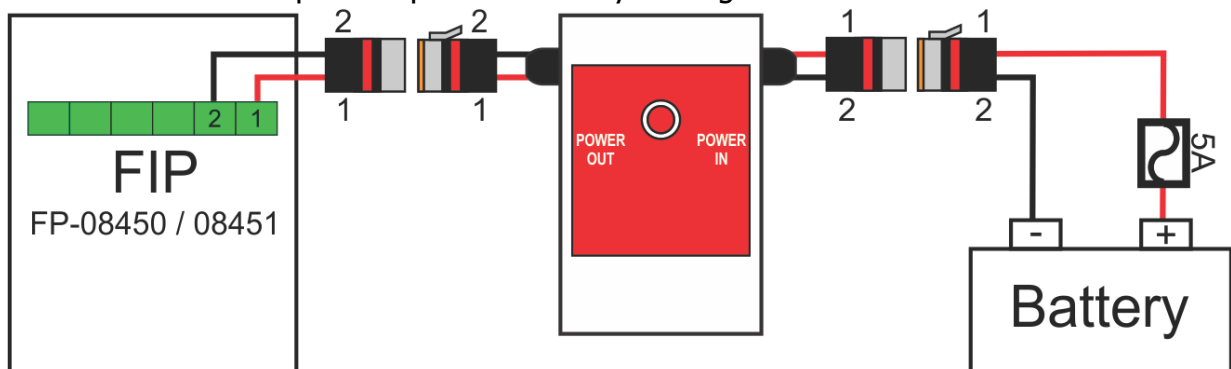

## 5 Commissioning

Commissioning should be performed when main supply and internal batteries are connected, and fire control panel is not in an alarm/fault condition.

1. Isolate and disconnect the any installed FirePro aerosol generators. This should generate a fault on the fire control panel.
2. Connect a FirePro FP-08800 Test Module.
3. Disconnect main power supply and ensure "Charging" LED indicator turns off.
4. Power supply will automatically switch to the internal batteries.
5. Ensure fire control panel remains operational and out of fault condition.
6. Reconnect main power supply.

## 6 Servicing and Maintenance

Inspection and servicing of the installed fire system should occur in accordance with the relevant Australian Standards. This should include a visual inspection of the enclosure to ensure the seals are intact.

Monitoring and operation of any installed modules should be tested as outlined in 6. Commissioning.

### 6.1 Replacing the Internal Batteries

The internal batteries **must** be changed every 3 years or if the backup batteries show signs of wear or damage. Both internal batteries must be replaced at the same time. New and old batteries **must not** be installed together. Old batteries should be disposed of in accordance with local regulations.

To replace the internal batteries:

1. Isolate and disconnect any installed FirePro aerosol generators. This should generate a fault on the fire control panel.
2. Connect a FirePro FP-08800 Test Module.
3. Disconnect main power supply and ensure "Charging" LED indicator turns off.
4. Isolate the Power Control Module by disconnecting both the output to the control panel and the input for the main power supply.
5. Remove the screws on the front to open the Power Control Module.
6. Disconnect and replace both internal batteries with 2x P/N FP-18156 Replacement Backup Battery.
7. Reconnect main supply input and control panel output.
8. If installed correctly, the "Charging" LED will indicate on the Power Control Module and the Control Panel will not be in a fault condition.
9. Disconnect the FirePro FP-08800 Test Module and reconnect all installed FirePro aerosol generators.



## 7 Power Control Module Version II – Auto Voltage Selection

The Power Control Module can operate on either 12-volt DC or 24-volt DC main supply. The module will auto sense the incoming supply and does not need any further adjustment.

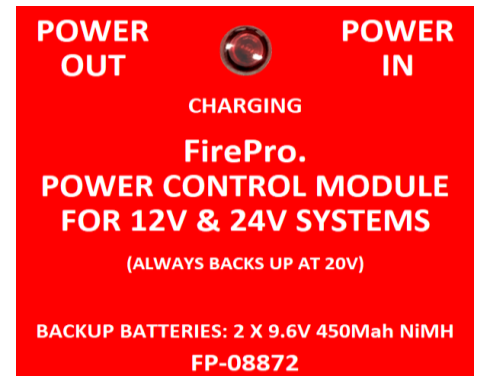

<b>Specifications</b>		
Enclosure material	Die Cast Aluminium	
Dimensions - mm	139L x 64W x 35D	
Ingress Protection	IP65	
Operating Temp.	-40 to 85°C	
Internal Battery	2 x 9.6v NiMH battery 450mAh	
Outgoing Fuse	1.5A Polyswitch self-resetting	
Incoming Fuse	1.5A Polyswitch self-resetting	
<b>Auto Voltage Selector</b>	<b>12vDC</b>	<b>24vDC</b>
Sensing Threshold V	Less than 15vDC	More than 15vDC
Backup Supply Voltage	20vDC	20vDC
Charging Voltage	13vDC	25vDC
Backup Supply takes over when incoming supply drops below	12vDC	25vDC
LED Charging Indicator	Incoming Power Over 13vDC	Incoming Power Over 25vDC
Output Current	max 1.5A	max 1.5A
<b>Troubleshooting</b>		
Problem	Possible Cause	Solution
"Charging" LED not illuminating	Incoming power below charging voltage. ----- Connection to incoming power. ----- Inline fuse has blown ----- Internal battery disconnected	Check connection and polarity of battery lead and any extension cables.  Check condition of the inline fuse and replace if necessary. Check connection to internal battery.

For additional assistance, contact your supplier.

## 8 Power Control Module Version I – Manual Voltage Selection

The Power Control Module can operate on either 12-volt DC or 24-volt DC main supply. A slide switch is located internally for the voltage selection.

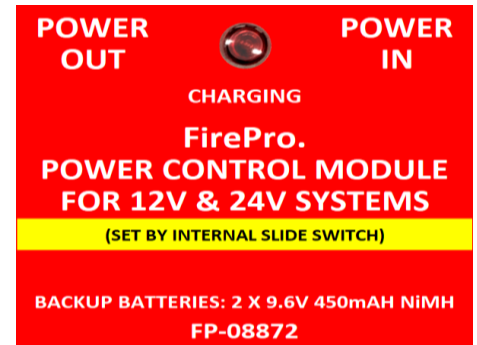

### Selecting Operating Voltage

The Power Control Module **MUST** be configured to operate on either 12-volt DC or 24-volt DC main supply. Switch is selected on the inside of the module. The incoming voltage must be the same as the incoming battery voltage.

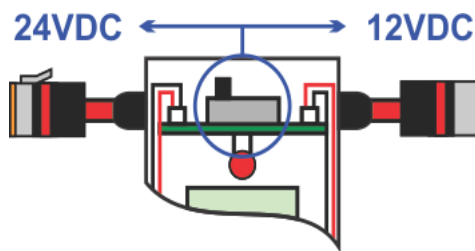

**Note:** Incorrect voltage selection may cause the internal batteries to not fully charge and may cause damage to the module.

Specifications		
Enclosure material	Die Cast Aluminium	
Dimensions - mm	139L x 64W x 35D	
Ingress Protection	IP65	
Operating Temp.	-40 to 85°C	
Internal Battery	2 x 9.6v NiMH battery 450mAh	
Outgoing Fuse	1.5A Polyswitch self-resetting	
Incoming Fuse	1.5A Polyswitch self-resetting	
Voltage Selector	12vDC	24vDC
Backup Supply Voltage	10vDC	20vDC
Charging Voltage	13vDC	24vDC
Backup Supply takes over when incoming supply drops below	10vDC	20vDC
LED Charging Indicator	Incoming Power Over 13vDC	Incoming Power Over 24vDC
Output Current	max 1.5A	max 1.5A
Troubleshooting		
Problem	Possible Cause	Solution
"Charging" LED not illuminating	Incoming power below charging voltage. ----- Connection to incoming power. ----- Inline fuse has blown ----- Internal battery disconnected	Check connection and polarity of battery lead and any extension cables.  Check condition of the inline fuse and replace if necessary. Check connection to internal battery.

For additional assistance, contact your supplier.

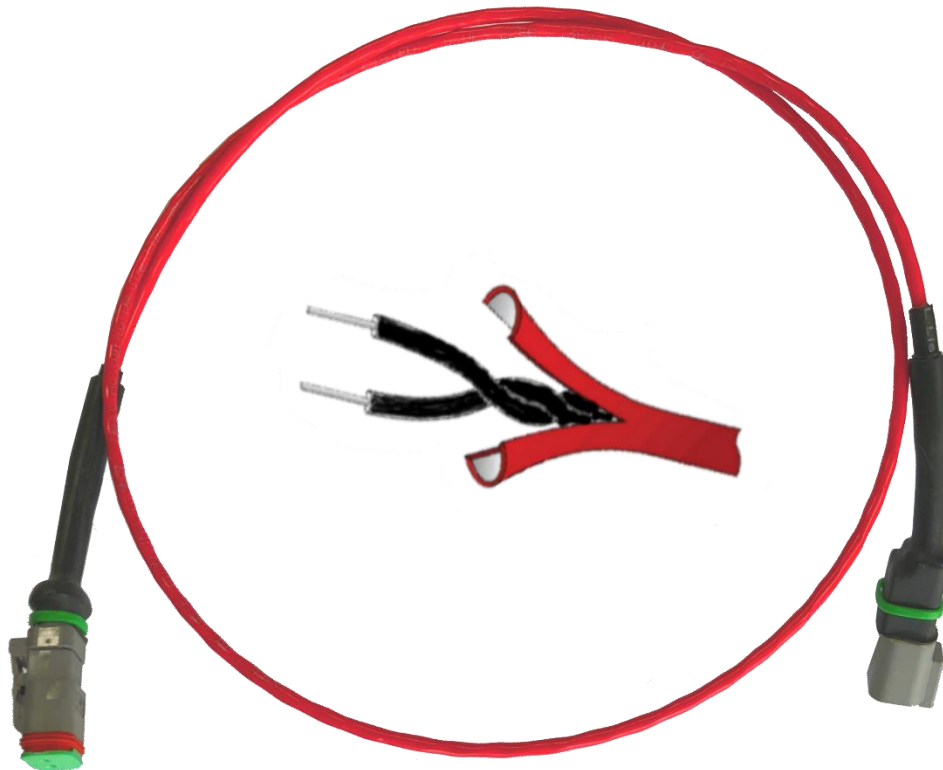

## Contents

2	Introduction .....	2
2.1	General Information.....	2
2.2	How Does it Work.....	2
3	Components List.....	2
4	Design Considerations.....	3
4.1	Mounting Location .....	3
4.2	Installation Requirements and Limitations .....	3
4.3	Cabling Requirements .....	4
4.4	Mounting Suggestion .....	4
5	Servicing and Maintenance.....	4
6	Specifications .....	4



## 1 Introduction

### 1.1 General Information

Linear Heat Detection (LHD) is a line-type form of fixed temperature heat detection that can be used in a variety of applications including vehicle, marine and industrial risks.

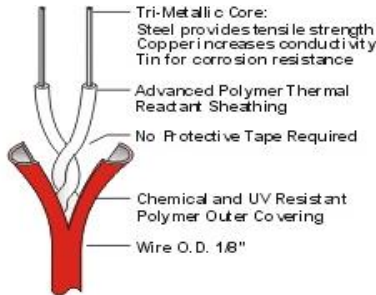

This linear cable can detect a fire anywhere along its entire length. LHD Cable detection systems are easy to design, install, operate and maintain.

Up to 100m of LHD Cable can be used on every zone of any approved conventional panel.

A low current is run through the cable which is monitored by the control panel. In a fire the LHD insulation will breakdown and make contact, signalling the control panel of an alarm.

### 1.2 How Does it Work

LHD Cable works using a twisted pair of extremely low resistance, tri-metallic conductors sheathed in advanced thermal polymers. When a fire occurs, the heat generated causes the internal thermal polymer insulation to melt. This allows the conductor wires to contact, creating a short circuit that signals an alarm.



## 2 Components List

### Linear Heat Detection Cable

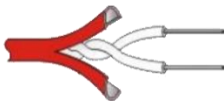

**FP-09510**  
Linear Heat Detection Cable 185° C

### Install Kit



**FP-09515**  
P Clip 1x DP-2000

Deutsch Plug 2 Pin M/F, c/w heatshrink

### Termination Options



**DP-2000**  
Deutsch Plug 2 Pin M/F, c/w heatshrink



**FP-09512**  
2way and EOL Junction Boxes with strain relief cable glands and 1x EOL for monitoring. (Obsolete)

- Note:** Standard detection temperature is 185°C. Different temperature detection cable available upon request.
- Note:** FP-09512 Junction boxes have been made obsolete and are to be used only in existing installations. Where installations are found to use Junction Boxes it is recommended to replace these with DP-2000 Deutsch Plug 2 Pin.



## 3 Design Considerations

### 3.1 Mounting Location

LHD Cable is to be installed on a smooth surface avoiding any obstructions that may inhibit detection, with appropriate clearance/protection from:

- Heat sources that may cause false alarms (e.g. exhaust manifold, turbo, etc)
- Moving parts or articulating joints
- Large amounts of water
- Corrosive chemicals

Using DP-2000 Deutsch Plugs, the LHD maintains an IP68 rating and is UV, oil and chemical resistant, however sources of these should be avoided to extend the life of the LHD cable. Where these cannot be avoided, FP-09500 Fire Rated Cable may be used to make extension leads to bypass these hazards and reduce any damage to the LHD.

### 3.2 Installation Requirements and Limitations

For total coverage, LHD should be looped around the risk area with spacing between cable no more than 600mm apart. The bend radius must never be less than 150mm. The maximum length of a continuous run of LHD is 100m metres. This includes any extension leads or manual actuators that may be included in the circuit.

LHD cable should never be installed in a high tension state, this may cause damage to the internal conductors. A service loop should be included to allow for normal expansion and contraction of the LHD due to temperature.

LHD cable must be mounted using only approved P Clips at minimum every 500mm. Additional P Clips should be used where necessary, particularly in high vibration or aggressive environments. P Clips are to be used to support bends and to prevent excessive sagging.

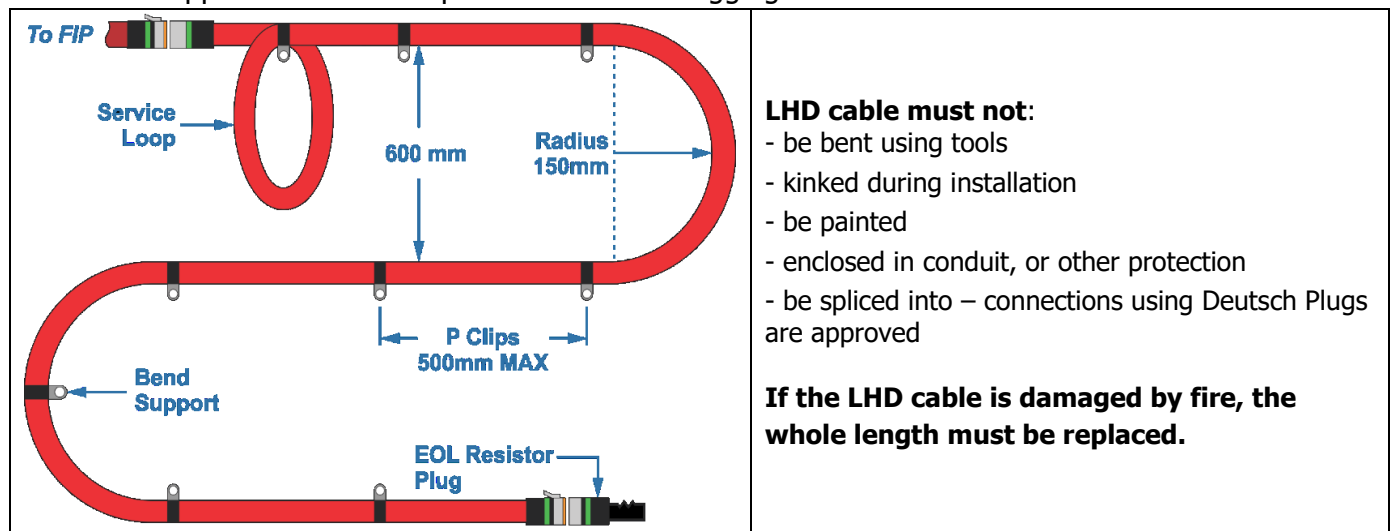

### 3.3 Cabling Requirements

Cable Requirements - All cabling in the FirePro Installation MUST be done using 0.75mm shielded Fire Rated Cable. Care taken to ensure that all cables are isolated, and that RF shielding on cable is stripped back to ensure that there is not accidental grounding. Cables are colour coded for easy identification.

Colour	Circuit
Red	Power Supply
Yellow 1	Activation
Yellow 2	Activation Delayed
Green 1	Detection 1
Green 2	Detection 2
Orange	Siren/Strobe
White	Relay Output

Extension Leads - Deutsch Plugs must be used to ensure water-proof connections are made throughout the installation.

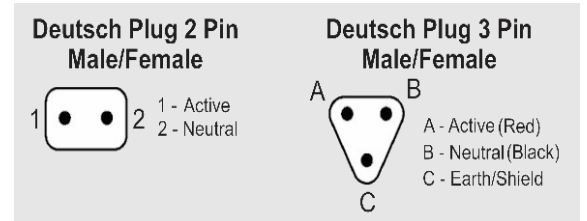

### 3.4 Mounting Suggestion

Mount the LHD Cable using P Clips to Aluminium Angle (25mm x 3mm Thick). This allows the LHD assembly to be then mounted in the risk. This process allows for easier inspection and maintenance process.

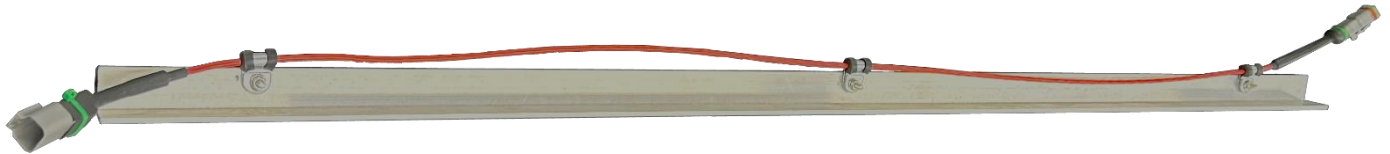

## 4 Servicing and Maintenance

Inspection and servicing of the installed fire system should occur in accordance with the relevant Australian Standards (i.e. AS1851 or AS5062). **Note:** Servicing should be performed, and no personnel should be in the risk area until the fire system is fully isolated.

1. Visually inspect the LHD cable. Ensure that the routing and installation procedures comply with the guidelines described in this document.
2. Ensure that there has been no damage to the cable, plug connections or junction boxes.
3. Isolate the fire suppression system and simulate an alarm condition on the detection circuit. This is done by closing the circuit where the linear end of line module is located by using a jumper wire. Verify the fire system enters an alarm condition and reset the control panel.

**Note: Do not** test LHD cable using heat source. LHD must be replaced after every heat detection event.

## 5 Specifications

<b>Max Run Length</b>	100 metres	<b>Resistance</b>	0.164 ohms/metre
<b>Max Voltage Rating</b>	30vDC	<b>Max Ambient Temp</b>	152° C
<b>Activating Temp</b>	185° C	<b>Diameter</b>	3.2mm
<b>Weight</b>	0.0223kg/metre	<b>Outer Sheath Material</b>	Polymer
<b>Bend Radius</b>	76.2mm		



**FP-0500 with BTA Fitted**

Height with BTA - 360mm  
Weight with BTA - 3400g

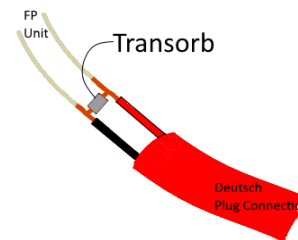
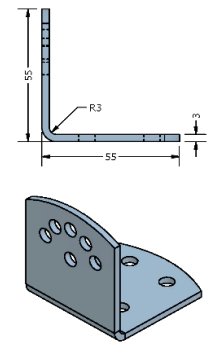
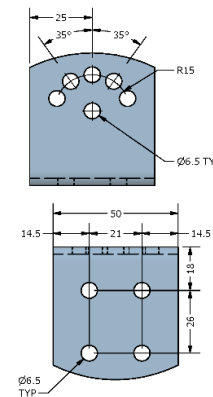
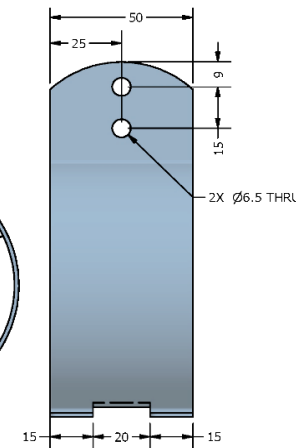
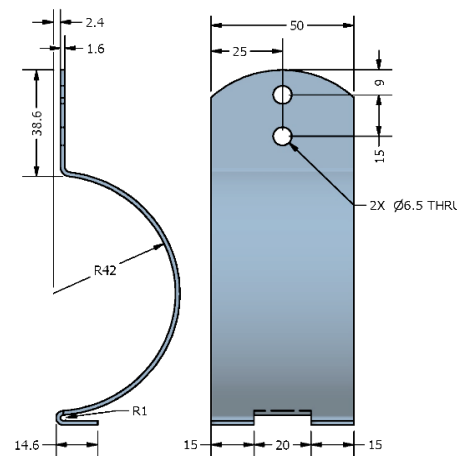
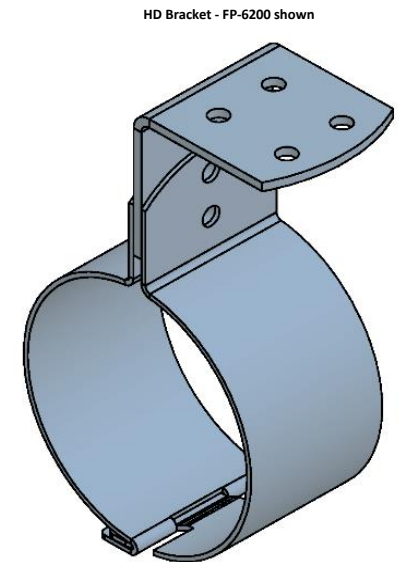
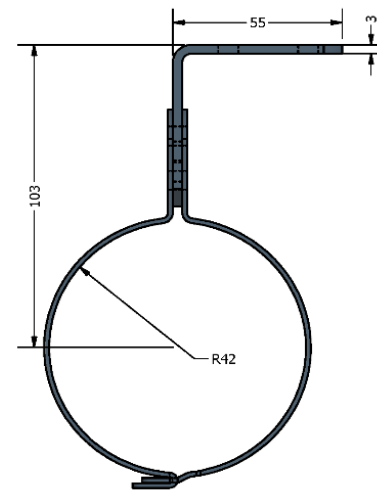

**Notes :**

- 1 Dimensi 295 x 84mm Excl Bracket
- 2 Weight 3.34kg Excl Bracket
- 3 Aerosol Canister Material - SS 304L
- 4 HD Bracket Material - 2.5mm SS316
- 5 Std Bracket Material - 1.5mm SS304L
- 6 Transorb installed in Electrical Units - Aust Only

Rev	Drawing Change	by	Date
	CRITICAL INSPECTION ITEMS DENOTED BY		
	TOLERANCES UNLESS OTHERWISE SPECIFIED		
FRAC. ±0.020	2 PL. DEC. ±0.010	3 PL. DEC. ±0.003	TIR

FIRE SAFETY EQUIPMENT PTY LTD					
Drawn By	Approved By	Title	Drawing No	Rev.	
PM		FirePro Aerosol Generator	0500	D	
Scale	Date	20-11-16			
		FP-0500			

## FirePro. Condensed Aerosol generators: FP-500S/T

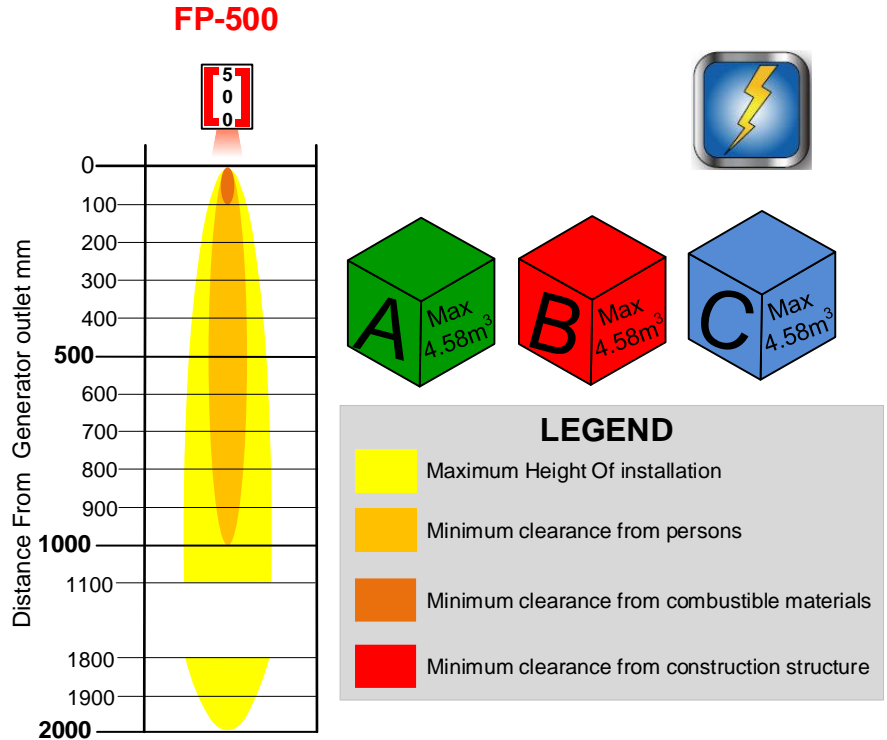

### Technical Data

<b>Mass of FPC</b> (Aerosol Generating Solid Compound)	500 g				
<b>Generators gross weight</b>	<b>Weight</b>		<b>Tolerance</b>		
	3340/3440 g		± 5%		
<b>Activation mode/s</b>	<b>Electrically</b>				
<b>Value of activation</b>	1.5 V DC, 0.8 A				
<b>FPC activation device</b>	Heating elements with 1.6-3.6 Ω Resistance				
<b>Activation line supervision current (Max)</b>	5 mA				
<b>Aerosol discharge time</b>	<b>Min.</b>		<b>Max</b>		
	5 seconds		10 seconds		
<b>Number of discharge outlet</b>	1				
<b>Generator dimension</b>	<b>Height</b>		<b>Diameter</b>		
	295/297 mm		84 mm		
<b>Self-activation temperature of FPC</b>	300° C				
<b>Classes of Fire</b> (NFPA 2010)	<b>A</b>	<b>B</b>	<b>C</b>	<b>D</b>	<b>K</b>
	√	√	√	NO	NO
<b>Generator Coverage Constraints</b>	Min ht: 0.45 m		Max area: 5.29 m <sup>2</sup>		
<b>Maximum height of installation</b>	2 m				
<b>Minimum clearance (mm)</b>	<b>From persons</b>		<b>From combustible material</b>		<b>From Generator's Casing</b>
	1000 mm		100 mm		6.4 mm
<b>Environmental parameters</b>	<b>ODP<sup>1</sup></b>		<b>GWP<sup>2</sup></b>		<b>ALT<sup>3</sup></b>
	Zero		Zero		Negligible <sup>4</sup>
<b>Technical Parameters</b>	<b>Electrical conductivity</b>		<b>Corrosion</b>		<b>Oxygen depletion After discharge</b>
	Nil up to 75KV		Negligible <sup>4</sup>		Negligible <sup>4</sup>
<b>Note</b>	<b>1</b>	ODP: Ozone Depletion Potential		<b>3</b>	ALT: Atmospheric Life Time
	<b>2</b>	GWP: Global Warming Potential		<b>4</b>	Within the parameters for use

<i>Manufactured by</i> <b>FirePro Systems Ltd.</b>	<i>Master dealers / Distributor</i>	<i>Trade Mark</i> <b>FirePro.</b>
---	-------------------------------------	--------------------------------------