

Instruction Manual
for Portable Compressors
English

XAMS 527 - XAMS 1150 CD7
XATS 487 - XATS 1050 CD7
XAHS 447 - XAHS 950 CD7
XAVS 407 - XAVS 900 CD7

Engine CAT C9

Instruction Manual
for Portable Compressor

XAMS 527 / XAMS 1150 Cd7
XATS 487 / XATS 1050 Cd7
XAHS 447 / XAHS 950 Cd7
XAVS 407 / XAVS 900 Cd7

Warranty and Liability Limitation

Use only authorized parts.

Any damage or malfunction caused by the use of unauthorized parts is not covered by Warranty or Product Liability.

The manufacturer does not accept any liability for any damage arising for modifications, additions or conversions made without the manufacturer's approval in writing.

Copyright 2034, Atlas Copco Airpower n.v., Antwerp, Belgium.

Any unauthorized use or copying of the contents or any part thereof is prohibited.

This applies in particular to trademarks, model denominations, part numbers and drawings.

Table of contents

1	SAFETY PRECAUTIONS	7
1.1	Introduction	7
1.2	General safety precautions	8
1.3	Safety during transport and installation	9
1.4	Safety during use and operation	10
1.5	Safety during maintenance and repair	12
1.6	Tool applications safety	14
1.7	Specific safety precautions	14
2	LEADING PARTICULARS	16
2.1	General description	16
2.2	Markings and information labels	18
2.3	Main parts	20
2.4	Regulating system	22
2.4.1	Overview	22
2.4.2	Air flow	24
2.4.3	Oil system	25
2.4.4	Continuous regulating system	26
2.5	Electric system	28
2.6	Options	30
2.6.1	ABS brakes	30
2.6.2	Aftercooler and waterseparator	30
2.6.3	Reheater	30
2.6.4	PD filter	30
2.6.5	QD filter	30
2.6.6	Spark arrestor	30
2.6.7	Inlet shut down valve	30
2.6.8	Cold weather equipment	30
2.6.9	Manifold with sensors	30
3	OPERATING INSTRUCTIONS	31
3.1	Parking, towing and lifting instructions	31
3.1.1	Parking instructions	32
3.1.2	Towing instructions	33
3.1.3	Lifting instructions	34
3.2	Before starting	35
3.2.1	Specific start procedure	39
3.3	Starting / Stopping	38
3.3.1	Control panel	38
3.3.2	Operations overview	39
3.3.4	Battery switch	39
3.3.4	Overview icons	40
3.3.5	Possible views	42
3.3.6	Starting	43
3.3.7	Stopping	50
3.3.8	Shutdown	52
3.3.9	Power off	52
3.3.10	Diesel particulate filter regeneration	52
3.3.11	Settings	57

3.3.12	Fault codes.....	59
3.3.13	Emergency stop.....	62
4	MAINTENANCE.....	62
4.1	Liability	62
4.2	Service paks.....	63
4.3	Service kits	63
4.4	Storage.....	63
4.5	Preventive maintenance schedule for the compressor.....	63
4.6	Oil specifications.....	66
4.6.1	Synthetic compressor oil PAROIL S.....	67
4.6.2	Mineral compressor oil PAROIL M.....	67
4.6.3	Synthetic engine oil PAROIL 5W30.....	67
4.6.4	Mineral engine oil PAROIL SAE 15W40.....	67
4.7	Oil level check.....	67
4.7.1	Check engine oil level	67
4.7.2	Check compressor oil level.....	68
4.8	Oil and oil filter change.....	68
4.8.1	Engine oil and oil filter change.....	68
4.8.2	Topping up the compressor oil	69
4.8.3	Compressor oil and oil filter change.....	70
4.9	Coolant specifications	72
4.9.1	PARCOOL EG	72
4.10	Coolant check.....	73
4.10.1	Monitoring coolant condition	73
4.10.2	Topping up of coolant.....	74
4.10.3	Replacing the coolant	74
4.11	Cleaning coolers.....	75
4.12	Battery care	75
4.12.1	Electrolyte.....	76
4.12.2	Activating a dry-charged battery	76
4.12.3	Recharging a battery.....	77
4.12.4	Battery maintenance	77
4.13	Compressor element overhaul.....	77
5	ADJUSTMENTS AND SERVICING PROCEDURES	78
5.1	Adjustment of the continuous regulating system	78
5.2	Air filters engine / compressor.....	79
5.2.1	Main parts	79
5.2.2	Cleaning the dust trap	80
5.2.3	Replacing the filter element and the safety cartridge	80
5.2.4	Air receiver	81
5.3	Safety valve.....	82
5.4	Fuel system.....	83
5.5	Brake adjustments	85
5.5.1	Brake shoe adjustment (no ABS)	85
5.5.2	Brake adjustment wagon	86
5.5.3	Frame maintenance and repair.....	87

6	PROBLEM SOLVING	88
7	AVAILABLE OPTIONS	91
8	TECHNICAL SPECIFICATIONS	93
8.1	Torque values	93
8.1.1	General torque values	93
8.1.2	Critical torque values	93
8.2	Compressor / Engine specifications	95
8.2.1	Reference conditions	95
8.2.2	Limitations	95
8.2.3	Performance data	96
8.2.4	Design data	96
9	DATAPLATE	99
10	LEGISLATION	100
10.1	Parts, subjected to Pressure Equipment Directive GB12243-89	100
10.2	Parts, subjected to Simple Pressure Vessel Directive GB150-1998	100
11	MAINTENANCE RECORD	101

Preface

Congratulations on the purchase of your Atlas Copco compressor. It is a solid, safe and reliable machine, built according to the latest technology. Follow the instructions in this booklet and we guarantee you years of troublefree operation. Please read the following instructions carefully before starting to use your compressor.

Always keep the manual available near the machine.

In all correspondence always mention the compressor type and serial number, shown on the data plate.

The company reserves the right to make changes without prior notice.

1 Safety precautions



To be read attentively and acted accordingly before towing, lifting, operating, performing maintenance or repairing the compressor.

1.1 Introduction

The policy of Atlas Copco is to provide the users of their equipment with safe, reliable and efficient products. Factors taken into account are among others:

- the intended and predictable future use of the products, and the environments in which they are expected to operate,
- applicable rules, codes and regulations,
- the expected useful product life, assuming proper service and maintenance,
- providing the manual with up-to-date information.

Before handling any product, take time to read the relevant instruction manual. Besides giving detailed operating instructions, it also gives specific information about safety, preventive maintenance, etc.

Keep the manual always at the unit location, easy accessible to the operating personnel.

See also the safety precautions of the engine and possible other equipment, which are separately sent along or are mentioned on the equipment or parts of the unit.

These safety precautions are general and some statements will therefore not always apply to a particular unit.

Only people that have the right skills should be allowed to operate, adjust, perform maintenance or repair on Atlas Copco equipment. It is the responsibility of management to appoint operators with the appropriate training and skill for each category of job.

Skill level 1: Operator

An operator is trained in all aspects of operating the unit with the push-buttons, and is trained to know the safety aspects.

Skill level 2: Mechanical technician

A mechanical technician is trained to operate the unit the same as the operator. In addition, the mechanical technician is also trained to perform maintenance and repair, as described in the instruction manual, and is allowed to change settings of the control and safety system. A mechanical technician does not work on live electrical components.

Skill level 3: Electrical technician

An electrical technician is trained and has the same qualifications as both the operator and the mechanical technician. In addition, the electrical technician may carry out electrical repairs within the various enclosures of the unit. This includes work on live electrical components.

Skill level 4: Specialist from the manufacturer

This is a skilled specialist sent by the manufacturer or its agent to perform complex repairs or modifications to the equipment.

In general it is recommended that not more than two people operate the unit, more operators could lead to unsafe operating conditions. Take necessary steps to keep unauthorized persons away from the unit and eliminate all possible sources of danger at the unit.

When handling, operating, overhauling and/or performing maintenance or repair on Atlas Copco equipment, the mechanics are expected to use safe engineering practices and to observe all relevant local safety requirements and ordinances. The following list is a reminder of special safety directives and precautions mainly applicable to Atlas Copco equipment.

These safety precautions apply to machinery processing or consuming air. Processing of any other gas requires additional safety precautions typical to the application and are not included herein.

Neglecting the safety precautions may endanger people as well as environment and machinery:

- ? endanger people due to electrical, mechanical or chemical influences,
- ? endanger the environment due to leakage of oil, solvents or other substances,
- ? endanger the machinery due to function failures.

All responsibility for any damage or injury resulting from neglecting these precautions or by non-observance of ordinary caution and due care required in handling, operating, maintenance or repair, also if not expressly mentioned in this instruction manual, is disclaimed by Atlas Copco.

The manufacturer does not accept any liability for any damage arising from the use of non-original parts and for modifications, additions or conversions made without the manufacturer's approval in writing.

If any statement in this manual does not comply with local legislation, the stricter of the two shall be applied.

Statements in these safety precautions should not be interpreted as suggestions, recommendations or inducements that it should be used in violation of any applicable laws or regulations.

1.2 General safety precautions

- 1 The owner is responsible for maintaining the unit in a safe operating condition. Unit parts and accessories must be replaced if missing or unsuitable for safe operation.
- 2 The supervisor, or the responsible person, shall at all times make sure that all instructions regarding machinery and equipment operation and maintenance are strictly followed and that the machines with all accessories and safety devices, as well as the consuming devices, are in good repair, free of abnormal wear or abuse, and are not tampered with.

- 3 Whenever there is an indication or any suspicion that an internal part of a machine is overheated, the machine shall be stopped but no inspection covers shall be opened before sufficient cooling time has elapsed; this to avoid the risk of spontaneous ignition of oil vapour when air is admitted.
- 4 Normal ratings (pressures, temperatures, speeds, etc.) shall be durably marked.
- 5 Operate the unit only for the intended purpose and within its rated limits (pressure, temperature, speeds, etc.).
- 6 The machinery and equipment shall be kept clean, i.e. as free as possible from oil, dust or other deposits.
- 7 To prevent an increase in working temperature, inspect and clean heat transfer surfaces (cooler fins, intercoolers, water jackets, etc.) regularly. See the **4.5 Preventive maintenance schedule for the compressor**
- 8 All regulating and safety devices shall be maintained with due care to ensure that they function properly. They may not be put out of action.
- 9 Care shall be taken to avoid damage to safety valves and other pressure-relief devices, especially to avoid plugging by paint, oil coke or dirt accumulation, which could interfere with the functioning of the device.
- 10 Pressure and temperature gauges shall be checked regularly with regard to their accuracy. They shall be replaced whenever outside acceptable tolerances.
- 11 Safety devices shall be tested as described in the maintenance schedule of the instruction manual to determine that they are in good operating condition. See the **4.5 Preventive maintenance schedule for the compressor**.
- 12 Mind the markings and information labels on the unit.
- 13 In the event the safety labels are damaged or destroyed, they must be replaced to ensure operator safety.
- 14 Keep the work area neat. Lack of order will increase the risk of accidents.
- 15 When working on the unit, wear safety clothing. Depending on the kind of activities these are: safety glasses, ear protection, safety helmet (including visor), safety gloves, protective clothing, safety shoes. Do not wear the hair long and loose (protect long hair with a hairnet), or wear loose clothing or jewelry.
- 16 Take precautions against fire. Handle fuel, oil and anti-freeze with care because they are inflammable substances. Do not smoke or approach with naked flame when handling such substances. Keep a fire-extinguisher in the vicinity.

1.3 Safety during transport and installation

To lift a unit, all loose or pivoting parts, e.g. doors and towbar, shall first be securely fastened.

Do not attach cables, chains or ropes directly to the lifting eye; apply a crane hook or lifting shackle meeting local safety regulations. Never allow sharp bends in lifting cables, chains or ropes.

Helicopter lifting is not allowed.

It is strictly forbidden to dwell or stay in the risk zone under a lifted load. Never lift the unit over people or residential areas. Lifting acceleration and retardation shall be kept within safe limits.

- 1 Before towing the unit:
 - . ascertain that the pressure vessel(s) is (are) depressurized,
 - . check the towbar, the brake system and the towing eye. Also check the coupling of the towing vehicle,
 - . check the towing and brake capability of the towing vehicle,
 - . check that the towbar, jockey wheel or stand leg is safely locked in the raised position,
 - . ascertain that the towing eye can swivel freely on the hook,

- . check that the wheels are secure and that the tyres are in good condition and inflated correctly,
 - . connect the signalisation cable, check all lights and connect the pneumatic brake couplers,
 - . attach the safety break-away cable or safety chain and emergency brake cable to the towing vehicle,
 - . remove wheel chocks, if applied, and disengage the parking brake.
- 2 To tow a unit use a towing vehicle of ample capacity. Refer to the documentation of the towing vehicle.
 - 3 If the unit is to be backed up by the towing vehicle, disengage the overrun brake mechanism (if it is not an automatic mechanism).
 - 4 Never exceed the maximum towing speed of the unit (mind the local regulations).
 - 5 Place the unit on level ground and apply the parking brake before disconnecting the unit from the towing vehicle. Unclip the safety break-away cable or safety chain. If the unit has no parking brake or jockey wheel, immobilize the unit by placing chocks in front of and/or behind the wheels. When the towbar can be positioned vertically, the locking device must be applied and kept in good order.
 - 6 To lift heavy parts, a hoist of ample capacity, tested and approved according to local safety regulations, shall be used.
 - 7 Lifting hooks, eyes, shackles, etc., shall never be bent and shall only have stress in line with their design load axis. The capacity of a lifting device diminishes when the lifting force is applied at an angle to its load axis.
 - 8 For maximum safety and efficiency of the lifting apparatus all lifting members shall be applied as near to perpendicular as possible. If required, a lifting beam shall be applied between hoist and load.
 - 9 Never leave a load hanging on a hoist.
 - 10 A hoist has to be installed in such a way that the object will be lifted perpendicular. If that is not possible, the necessary precautions must be taken to prevent load-swinging, e.g. by using two hoists, each at approximately the same angle not exceeding 30° from the vertical.
 - 11 Locate the unit away from walls. Take all precautions to ensure that hot air exhausted from the engine and driven machine cooling systems cannot be recirculated. If such hot air is taken in by the engine or driven machine cooling fan, this may cause overheating of the unit; if taken in for combustion, the engine power will be reduced.
 - 12 Before moving the compressor, switch it off.

1.4 Safety during use and operation

- 1 When the unit has to operate in a fire-hazardous environment, each engine exhaust has to be provided with a spark arrestor to trap incendiary sparks.
- 2 The exhaust contains carbon monoxide which is a lethal gas. When the unit is used in a confined space, conduct the engine exhaust to the outside atmosphere by a pipe of sufficient diameter; do this in such a way that no extra back pressure is created for the engine. If necessary, install an extractor. Observe any existing local regulations. Make sure that the unit has sufficient air intake for operation. If necessary, install extra air intake ducts.
- 3 When operating in a dust-laden atmosphere, place the unit so that dust is not carried towards it by the wind. Operation in clean surroundings considerably extends the intervals for cleaning the air intake filters and the cores of the coolers.
- 4 Close the compressor air outlet valve before connecting or disconnecting a hose. Ascertain that a hose is fully depressurized before disconnecting it. Before blowing compressed air through a hose or air line, ensure that the open end is held securely, so that it cannot whip and cause injury.
- 5 The air line end connected to the outlet valve must be safeguarded with a safety cable, attached next to the valve.

- 6 No external force may be exerted on the air outlet valves, e.g. by pulling on hoses or by installing auxiliary equipment directly to a valve, e.g. a water separator, a lubricator, etc. Do not step on the air outlet valves.
- 7 Never move a unit when external lines or hoses are connected to the outlet valves, to avoid damage to valves, manifold and hoses.
- 8 Do not use compressed air from any type of compressor, without taking extra measures, for breathing purposes as this may result in injury or death. For breathing air quality, the compressed air must be adequately purified according to local legislation and standards. Breathing air must always be supplied at stable, suitable pressure.
- 9 Distribution pipework and air hoses must be of correct diameter and suitable for the working pressure. Never use frayed, damaged or deteriorated hoses. Replace hoses and flexibles before the lifetime expires. Use only the correct type and size of hose end fittings and connections.
- 10 If the compressor is to be used for sand-blasting or will be connected to a common compressed-air system, fit an appropriate non-return valve (check valve) between compressor outlet and the connected sand-blasting or compressed-air system. Observe the right mounting position/direction.
- 11 Before removing the oil filler plug, ensure that the pressure is released by opening an air outlet valve.
- 12 Never remove a filler cap of the cooling water system of a hot engine. Wait until the engine has sufficiently cooled down.
- 13 Never refill fuel while the unit is running, unless otherwise stated in the Atlas Copco Instruction Book (AIB). Keep fuel away from hot parts such as air outlet pipes or the engine exhaust. Do not smoke when fuelling. When fuelling from an automatic pump, an earthing cable should be connected to the unit to discharge static electricity. Never spill nor leave oil, fuel, coolant or cleansing agent in or around the unit.
- 14 All doors shall be shut during operation so as not to disturb the cooling air flow inside the bodywork and/or render the silencing less effective. A door should be kept open for a short period only e.g. for inspection or adjustment.
- 15 Periodically carry out maintenance works according to the maintenance schedule.
- 16 Stationary housing guards are provided on all rotating or reciprocating parts not otherwise protected and which may be hazardous to personnel. Machinery shall never be put into operation, when such guards have been removed, before the guards are securely reinstalled.
- 17 Noise, even at reasonable levels, can cause irritation and disturbance which, over a long period of time, may cause severe injuries to the nervous system of human beings. When the sound pressure level, at any point where personnel normally has to attend, is:
 - . below 70 dB(A): no action needs to be taken,
 - . above 70 dB(A): noise-protective devices should be provided for people continuously being present in the room,
 - . below 85 dB(A): no action needs to be taken for occasional visitors staying a limited time only,
 - . above 85 dB(A): room to be classified as a noise-hazardous area and an obvious warning shall be placed permanently at each entrance to alert people entering the room, for even relatively short times, about the need to wear ear protectors,
 - . above 95 dB(A): the warning(s) at the entrance(s) shall be completed with the recommendation that also occasional visitors shall wear ear protectors,
 - . above 105 dB(A): special ear protectors that are adequate for this noise level and the spectral composition of the noise shall be provided and a special warning to that effect shall be placed at each entrance.
- 18 The unit has parts, which may be accidentally touched by personnel, of which the temperature can be in excess of 80 °C (176 °F). The insulation or safety guard, protecting these parts shall not be removed before the parts have cooled down to room temperature.

- 19 Never operate the unit in surroundings where there is a possibility of taking in flammable or toxic fumes.
- 20 If the working process produces fumes, dust or vibration hazards, etc., take the necessary steps to eliminate the risk of personnel injury.
- 21 When using compressed air or inert gas to clean down equipment, do so with caution and use the appropriate protection, at least safety glasses, for the operator as well as for any bystander. Do not apply compressed air or inert gas to your skin or direct an air or gas stream at people. Never use it to clean dirt from your clothes.
- 22 When washing parts in or with a cleaning solvent, provide the required ventilation and use appropriate protection such as a breathing filter, safety glasses, rubber apron and gloves, etc.
- 23 Safety shoes should be compulsory in any workshop and if there is a risk, however small, of falling objects, wearing of a safety helmet should be included.
- 24 If there is a risk of inhaling hazardous gases, fumes or dust, the respiratory organs must be protected and depending on the nature of the hazard, so must the eyes and skin.
- 25 Remember that where there is visible dust, the finer, invisible particles will almost certainly be present too; but the fact that no dust can be seen is not a reliable indication that dangerous, invisible dust is not present in the air.
- 26 Never operate the unit at pressures or speeds below or in excess of its limits as indicated in the technical specifications.

1.5 Safety during maintenance and repair

Maintenance, overhaul and repair work shall only be carried out by adequately trained personnel; if required, under supervision of someone qualified for the job.

- 1 Use only the correct tools for maintenance and repair work, and only tools which are in good condition.
- 2 Parts shall only be replaced by genuine Atlas Copco replacement parts.
- 3 All maintenance work, other than routine attention, shall only be undertaken when the unit is stopped. Steps shall be taken to prevent inadvertent starting. In addition, a warning sign bearing a legend such as "work in progress; do not start" shall be attached to the starting equipment. On engine-driven units the battery shall be disconnected and removed or the terminals covered by insulating caps. On electrically driven units the main switch shall be locked in open position and the fuses shall be taken out. A warning sign bearing a legend such as "work in progress; do not supply voltage" shall be attached to the fuse box or main switch.
- 4 Before dismantling any pressurized component, the compressor or equipment shall be effectively isolated from all sources of pressure and the entire system shall be relieved of pressure. Do not rely on non-return valves (check valves) to isolate pressure systems. In addition, a warning sign bearing a legend such as "work in progress; do not open" shall be attached to each of the outlet valves.
- 5 Prior to stripping an engine or other machine or undertaking major overhaul on it, prevent all movable parts from rolling over or moving.
- 6 Make sure that no tools, loose parts or rags are left in or on the machine. Never leave rags or loose clothing near the engine air intake.
- 7 Never use flammable solvents for cleaning (fire-risk).
- 8 Take safety precautions against toxic vapours of cleaning liquids.
- 9 Never use machine parts as a climbing aid.
- 10 Observe scrupulous cleanliness during maintenance and repair. Keep away dirt, cover the parts and exposed openings with a clean cloth, paper or tape.
- 11 Never weld on or perform any operation involving heat near the fuel or oil systems. Fuel and oil tanks must be completely purged, e.g. by steam-cleaning, before carrying out such operations. Never weld on, or in any way modify, pressure vessels. Disconnect the alternator cables during arc welding on the unit.

- 12 Support the towbar and the axle(s) securely if working underneath the unit or when removing a wheel. Do not rely on jacks.
- 13 Do not remove any of, or tamper with, the sound-damping material. Keep the material free of dirt and liquids such as fuel, oil and cleansing agents. If any sound-damping material is damaged, replace it to prevent the sound pressure level from increasing.
- 14 Use only lubricating oils and greases recommended or approved by Atlas Copco or the machine manufacturer. Ascertain that the selected lubricants comply with all applicable safety regulations, especially with regard to explosion or fire-risk and the possibility of decomposition or generation of hazardous gases. Never mix synthetic with mineral oil.
- 15 Protect the engine, alternator, air intake filter, electrical and regulating components, etc., to prevent moisture ingress, e.g. when steam-cleaning.
- 16 When performing any operation involving heat, flames or sparks on a machine, the surrounding components shall first be screened with non-flammable material.
- 17 Never use a light source with open flame for inspecting the interior of a machine.
- 18 Disconnect –battery-clamp before starting electrical servicing or welding (evt. turn battery-switch in “off” position).
- 19 When repair has been completed, the machine shall be barred over at least one revolution for reciprocating machines, several revolutions for rotary ones to ensure that there is no mechanical interference within the machine or driver. Check the direction of rotation of electric motors when starting up the machine initially and after any alteration to the electrical connection(s) or switch gear, to check that the oil pump and the fan function properly.
- 20 Maintenance and repair work should be recorded in an operator’s logbook for all machinery. Frequency and nature of repairs can reveal unsafe conditions.
- 21 When hot parts have to be handled, e.g. shrink fitting, special heat-resistant gloves shall be used and, if required, other body protection shall be applied.
- 22 When using cartridge type breathing filter equipment, ascertain that the correct type of cartridge is used and that its useful service life is not surpassed.
- 23 Make sure that oil, solvents and other substances likely to pollute the environment are properly disposed of.
- 24 Before clearing the unit for use after maintenance or overhaul, check that operating pressures, temperatures and speeds are correct and that the control and shutdown devices function correctly.

1.6 Tool applications safety

Apply the proper tool for each job. With the knowledge of correct tool use and knowing the limitations of tools, along with some common sense, many accidents can be prevented.

Special service tools are available for specific jobs and should be used when recommended. The use of these tools will save time and prevent damage to parts.

1.7 Specific safety precautions

Batteries

When servicing batteries, always wear protecting clothing and glasses.

- 1 The electrolyte in batteries is a sulphuric acid solution which is fatal if it hits your eyes, and which can cause burns if it contacts your skin. Therefore, be careful when handling batteries, e.g. when checking the charge condition.

- 2 Install a sign prohibiting fire, open flame and smoking at the post where batteries are being charged.
- 3 When batteries are being charged, an explosive gas mixture forms in the cells and might escape through the vent holes in the plugs. Thus an explosive atmosphere may form around the battery if ventilation is poor, and can remain in and around the battery for several hours after it has been charged. Therefore:
 - never smoke near batteries being, or having recently been, charged,
 - never break live circuits at battery terminals, because a spark usually occurs.
- 4 When connecting an auxiliary battery (AB) in parallel to the unit battery (CB) with booster cables: connect the + pole of AB to the + pole of CB, then connect the - pole of CB to the mass of the unit. Disconnect in the reverse order.

Pressure vessels

Maintenance/installation requirements:

- 1 The vessel can be used as pressure vessel or as separator and is designed to hold compressed air for the following application:
 - pressure vessel for compressor,
 - medium AIR/OIL,
 - and operates as detailed on the data plate of the vessel:
 - the maximum working pressure ps in bar (psi),
 - the maximum working temperature Tmax in Centigrade (Fahrenheit),
 - the minimum working temperature Tmin in Centigrade (Fahrenheit),
 - the capacity of the vessel V in l (US gal, Imp gal, cu.ft).
- 2 The pressure vessel is only to be used for the applications as specified above and in accordance with the technical specifications. Safety reasons prohibit any other applications.
- 3 National legislation requirements with respect to re-inspection must be complied with.
- 4 No welding or heat treatment of any kind is permitted to those vessel walls which are exposed to pressure.
- 5 The vessel is provided and may only be used with the required safety equipment such as manometer, overpressure control devices, safety valve, etc.
- 6 Draining of condensate shall be performed daily when vessel is in use.
- 7 Installation, design and connections should not be changed.
- 8 Bolts of cover and flanges may not be used for extra fixation.

Safety valves

Operating & Maintenance

Only trained and technically competent personnel should consider overhaul, re-set or performance testing of safety valves.

The safety valve is supplied with either a lead security seal or crimped cover to deter unauthorised access to the pressure regulation device.

Under no circumstances should the set pressure of the safety valve be altered to a different pressure than that stamped on the valve without the permission of the installation designer.

If the set pressure must be altered then use only correct parts supplied by Seetru and in accordance with the

instructions available for the valve type.

Safety valves must be frequently tested and regularly maintained.

The set pressure should be periodically checked for accuracy.

When fitted, the lifting device should be operated at pressures not less than 75% of the set pressure to ensure free and easy movement of internal parts.

The frequency of tests is influenced by factors such as the severity of the operating environment and aggressiveness of the pressurised medium.

Soft seals and springs should be replaced as part of the maintenance procedure.

Do not paint or coat the installed safety valve.

(see also **4.5 Preventive maintenance schedule for the compressor**).

2 Leading particulars

2.1 General description

The XAMS1150 CdH is a silenced, single-stage, oil-injected screw compressor, built for a nominal effective working pressure of 8.6 bar (125 psi).

- Engine

The compressor is driven by a liquid-cooled diesel engine.

The engine's power is transmitted to the compressor element through a heavy-duty coupling.

- Compressor

The compressor casing houses two screw-type rotors, mounted on ball and roller bearings. The male rotor, driven by the engine, drives the female rotor. The compressor delivers pulsation-free air.

Injected oil is used for sealing, cooling and lubricating purposes.

- Compressor oil system

The oil is boosted by air pressure. The system has no oil pump.

The oil is removed from the air, in the air/oil vessel at first by centrifugal force, secondly through the oil separator element.

The vessel is provided with an oil level indicator.

- Regulation

The compressor is provided with a continuous regulating system and a blow-off valve which is integrated in the unloader assembly. The valve is closed during operation by air receiver pressure and opens by air receiver pressure via the compressor element when the compressor is stopped.

When the air consumption increases, the air receiver pressure will decrease and vice versa.

This receiver pressure variation is sensed by the regulating valve which, by means of control air to the unloader and an electronic engine speed regulator, matches the air output to the air consumption. The air receiver pressure is maintained between the pre-selected working pressure and the corresponding unloading pressure.

- Cooling system

The engine is provided with a liquid-cooler and intercooler and the compressor is provided with an oil cooler. (For available options see chapter 7 **Available options**.)

The cooling air is generated by a fan, driven by the engine.

- Safety devices

A thermal shut-down sensor protects the compressor against overheating. The air receiver is provided with a safety valve.

The engine is equipped with low oil pressure and high coolant temperature shut-down sensors.

- Frame and axles

The compressor/engine unit is supported by rubber buffers in the frame.

The standard compressor has a towbar with parking brakes.

For available options see chapter **7 Available options**.

- Bodywork

The bodywork has openings for the intake and outlet of cooling air and hinged doors for maintenance and service operations. The bodywork is internally lined with sound-absorbing material.

- Lifting beam

A lifting beam is accessible when a small door at the top is opened.

- Control panel

The control panel grouping the air pressure gauge, control switch etc., is placed at the left hand/ rear end corner.

- Data plate







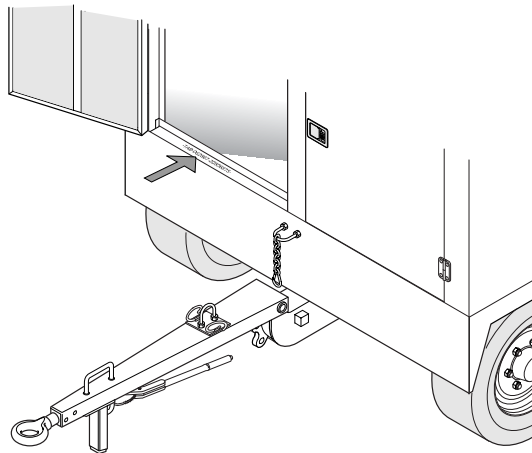







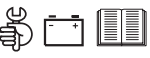

The compressor is furnished with a data plate showing the product code, the unit serial number and the working pressure (see chapter **9 Dataplate**).

- Serial number

The serial number is stamped in at the front of the compressor on the upper edge of the frame behind the right door. It is also mentioned on the data plate and inside the control box.



2.2 Markings and information labels

	Dangerous outlet gases.
	Danger, heat flat.
	Electrocution hazard.
 PAROIL S	Atlas Copco synthetic compressor oil.
 PAROIL SAE 15W40	Atlas Copco mineral engine oil.
	Manual.
	Read the instruction manual before working on the battery.
	Reset fuse.
	On / off button.
	Prohibition to open air valves without connected hoses.
	Rotation direction.
	Inlet.
	Outlet.
	Compressor oil drain.
	Read the instruction manual before starting.
	Service every 24 hours.

	Warning! Part under pressure.
	Do not stand on outlet valves.
	Start-Stop indication of switch.
	Do not run the compressor with open doors.
	Lifting permitted.
	Use diesel fuel only.
5.5 bar (80 psi)	Tyre pressure.
	Sound power level in accordance with Directive 00/14/EEC (expressed in dB (A)).
	Fork lifting permitted.
	Don't lift here.
	Read the instruction manual before lifting.
	Filler cap coolant.
	Read the instruction manual before topping up with coolant.
	Service point.
	Circuit breaker.
	Do not run the compressor when the baffles are not in the right position.

2.3 Main parts

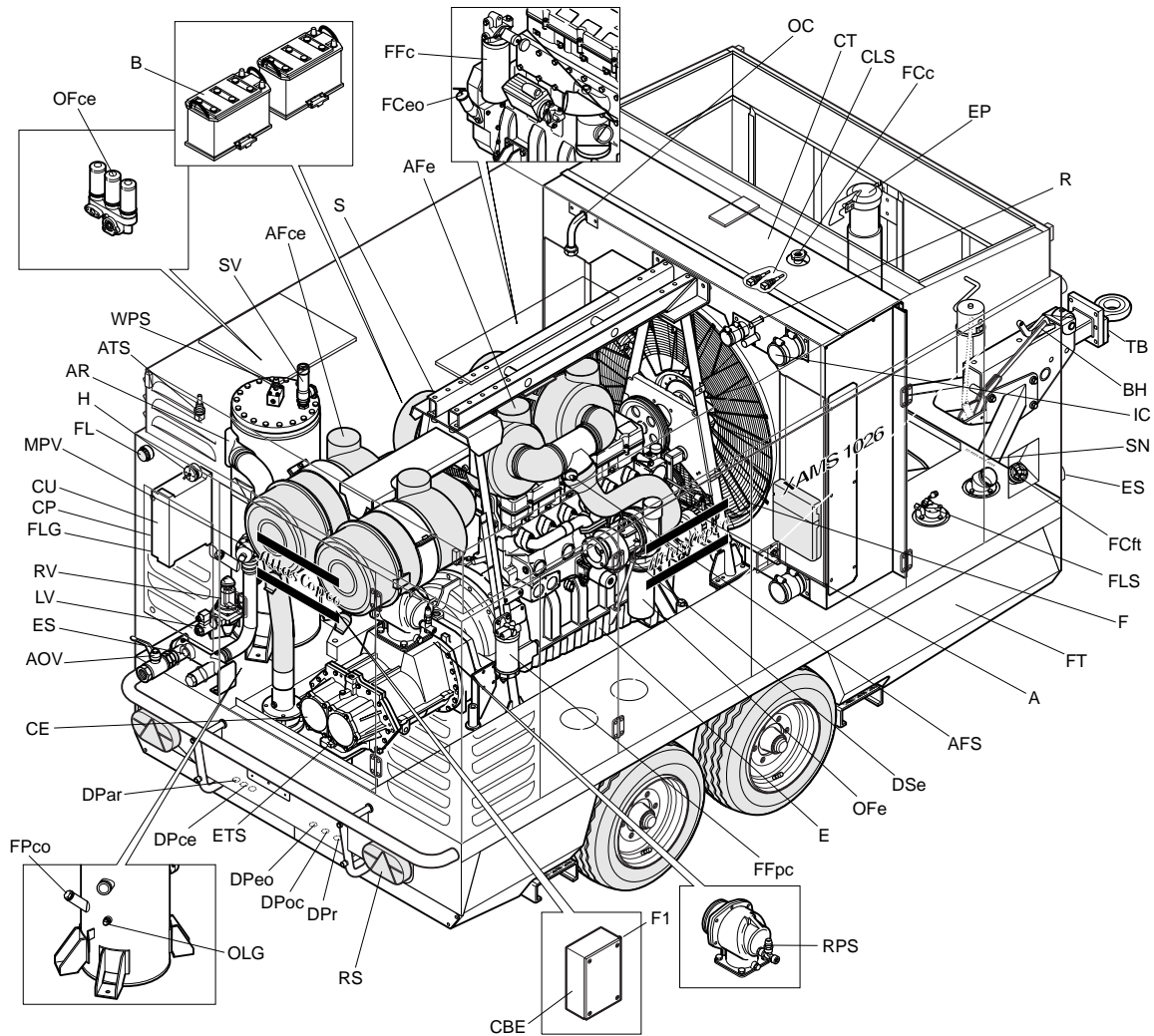

Reference	Name
A	Alternator
AFce	Air Filter (compressor element)
AFe	Air Filter (engine)
AFS	Air Filter Switch
AOV	Air Outlet Valves
AR	Air Receiver
ATS	Ambient Temperature Sensor
B	Battery
BH	Brake Handle
CBE	Cubicle for Electrical devices
CE	Compressor Element
CLS	Coolant Level Switch
CP	Control Panel
CT	Coolant Tank

Reference	Name
CU	Control Unit
DPar	Drain Plug Air Receiver
DPce	Drain Plug Compressor Element
DPeo	Drain Plug Engine Oil
DPoc	Drain Plug Oil Cooler
DPr	Drain Plug Radiator
DSe	Engine Oil Level Dipstick
E	Engine
EP	Exhaust Pipe
ES	Emergency Stop
ETS	Element Temperature Sensor
F	Fan
F1	Fuse
FCeo	Filler Cap (engine oil)
FCft	Filler Cap (fuel tank)
FCc	Filler Cap (coolant)
FFc	Fuel Filter Caterpillar
FFpc	Fuel Prefilter Caterpillar
FL	Flash Light
FLG	Fuel Level Gauge
FLS	Fuel Level Sensor
FPco	Filler Plug (oil compressor element)
FT	Fuel Tank
H	Horn
IC	Intercooler
LV	Loading Valve
MPV	Minimum Pressure Valve
OC	Oil Cooler
OFce	Oil Filter (compressor element)
OFe	Oil Filter (engine)
OLG	Oil Level Gauge
R	Radiator
RPS	Regulating Pressure Sensor
RS	Roadsignalisation
RV	Regulating Valve
S	Starting Motor
SN	Serial Number
SV	Safety Valve
TB	Towbar
WPS	Working Pressure Sensor

2.4 Regulating system

2.4.1 Overview

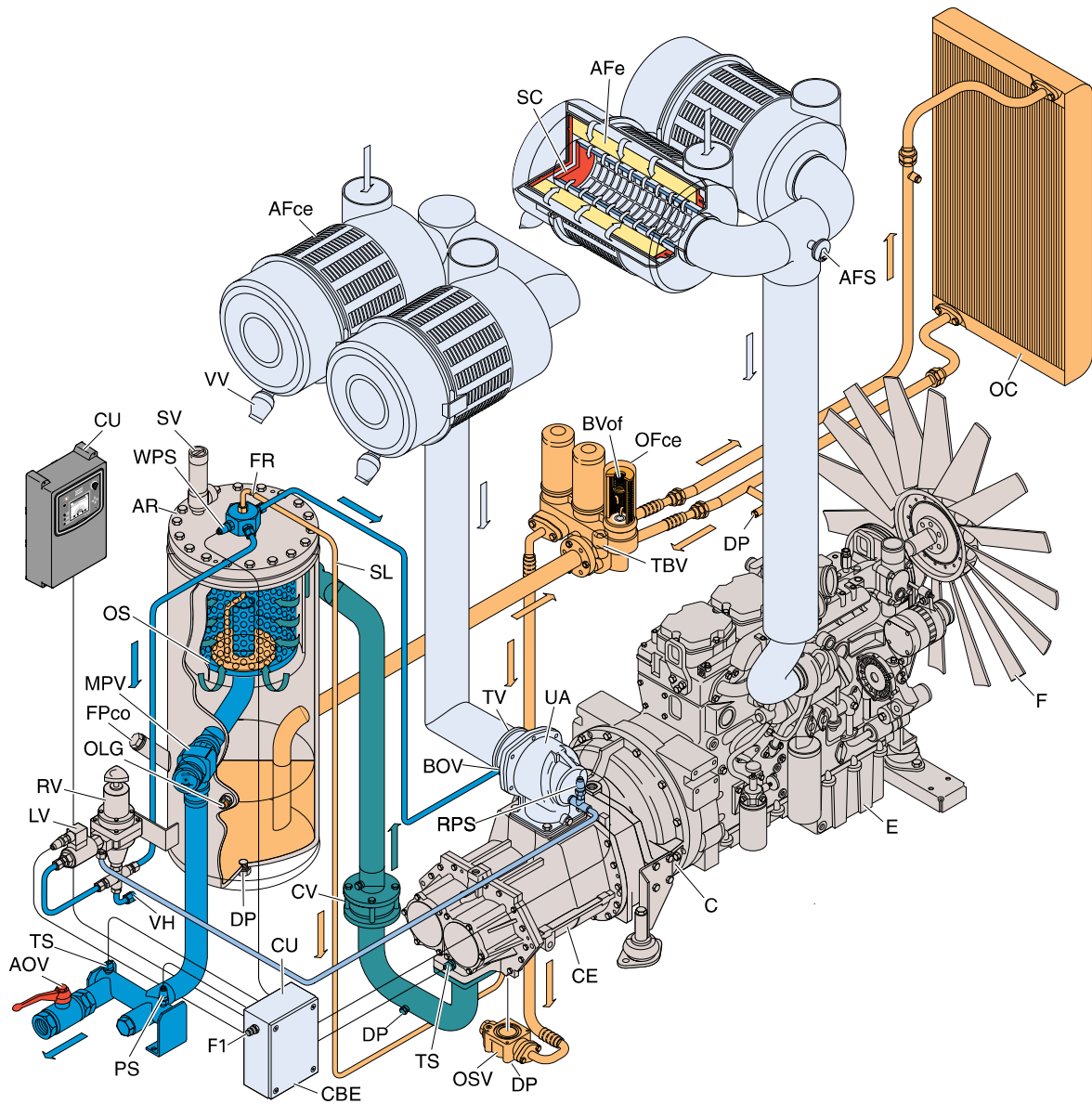

Reference	Name
AFce	Air Filter (compr. element)
AFe	Air Filter (engine)
AFS	Air Filter Switch
AOV	Air Outlet Valves
AR	Air Receiver
BOV	Blow Off Valve
BVof	Bypass Valve oil filter

Reference	Name
C	Coupling
CBE	Cubicle for Electrical devices
CE	Compressor Element
CU	Control Unit
CV	Check Valve
DP	Drain Plug
E	Engine
F	Fan
F1	Fuse
FPco	Filler Plug (oil compressor element)
FR	Flow Restrictor
LV	Loading Valve
MPV	Minimum Pressure Valve
OC	Oil Cooler
OFce	Oil Filter (compressor element)
OLG	Oil Level Gauge
OS	Oil Separator
OSV	Oil Stop Valve
PS	Pressure Sensor
RPS	Regulating Pressure Sensor
RV	Regulating Valve
SC	Safety Cartridge
SL	Scavenge Line
SV	Safety Valve
TBV	Thermostatic Bypass Valve
TS	Temperature Sensor
TV	Throttle Valve
UA	Unloader Assembly
VH	Vent hole
VV	Vacuator Valve
WPG	Working Pressure Gauge
WPS	Working Pressure Sensor

2.4.2 Air flow

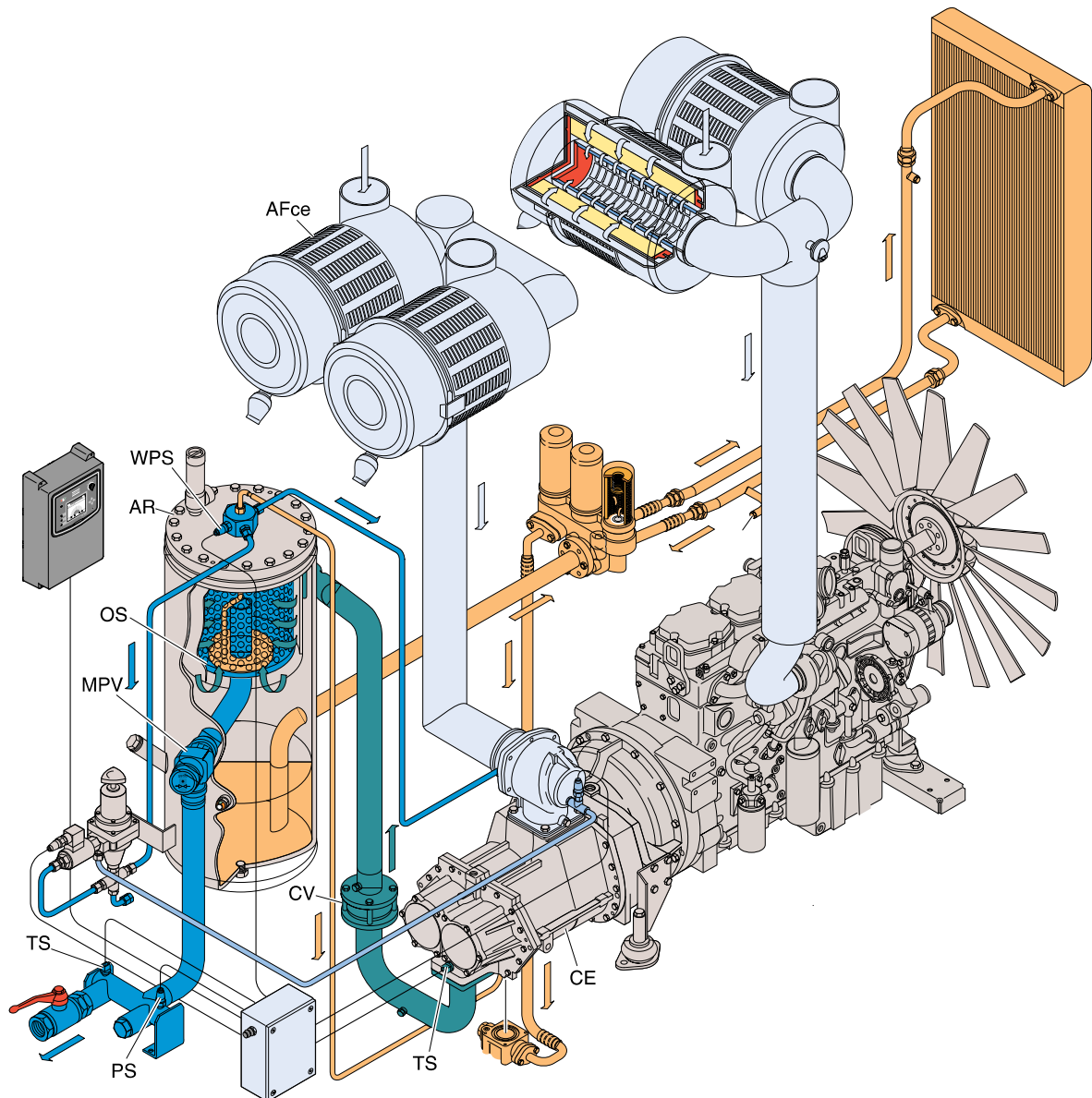

Air drawn through the airfilter (AFce) into the compressor element (CE) is compressed. At the element outlet, compressed air and oil pass into the air receiver/oil separator (AR/OS).

The check valve (CV) prevents blow-back of compressed air when the compressor is stopped. In the air receiver/oil separator (AR/OS), most of the oil is removed from the air/oil mixture.

The oil collects in the receiver and on the bottom of the separator element.

The air leaves the receiver via a minimum pressure valve (MPV) which prevents the receiver pressure from dropping below the minimum working pressure, even when the air outlet valves are open (specified in section **8.3.2 Limitations**). This ensures adequate oil injection and prevents oil consumption. The minimum pressure valve (MPV) also functions as a check valve.

The system comprises temperature sensors (TS), pressure sensors (PS) and a working pressure sensor (WPS).

2.4.3 Oil system

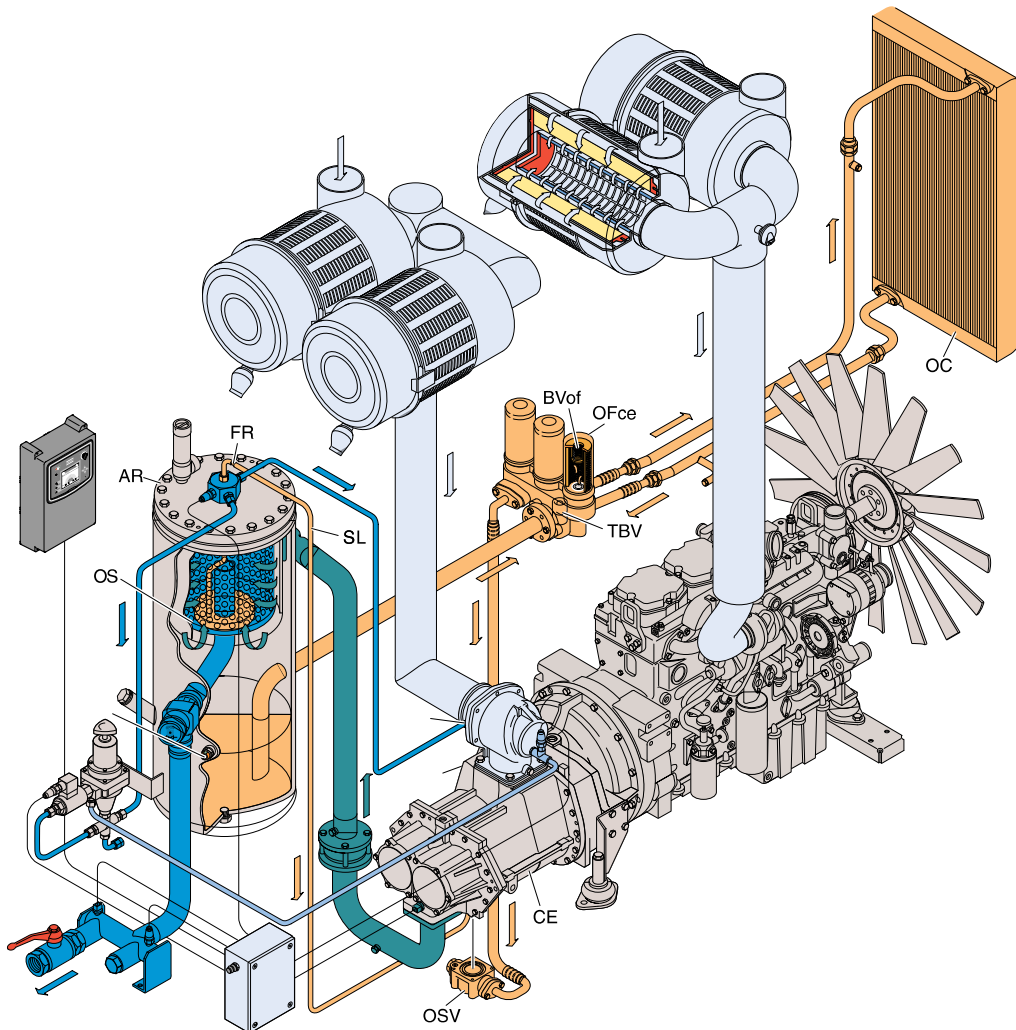

The lower part of the air receiver (AR) serves as oil tank.

Air pressure forces the oil from the air receiver/oil separator (AR/OS) through the oil cooler (OC), the oil filters (OF) and the oil stop valve (OSV) to the compressor element (CE).

When the compressor is stopped and / or there is no pressure in the system, the oil stop valve (OSV) prevents the oil from flowing back into the compressor element.

The thermostatic by-pass valve (TBV) starts opening when the oil temperature is 80 Centigrade (176 Fahrenheit).

The compressor element has an oil gallery in the bottom of its casing. The oil for rotor lubrication, cooling and sealing is injected through holes in the gallery.

Lubrication of the bearings is ensured by oil injected into the bearing housings.

The injected oil, mixed with the compressed air, leaves the compressor element and re-enters the air receiver, where it is separated from the air as described in section **2.4.2 Air flow**. The oil that collects in the bottom of the oil separator element is returned to the system through a scavenging line (SL), which is provided with a flow restrictor (FR).

The oil filter by-pass valve opens when the pressure drop over the filter is above normal because of a clogged filter. The oil then by-passes the filter without being filtered. For this reason, the oil filter must be replaced at regular intervals (see section **4.5 Preventive maintenance schedule for the compressor**).

2.4.4 Continuous regulating system

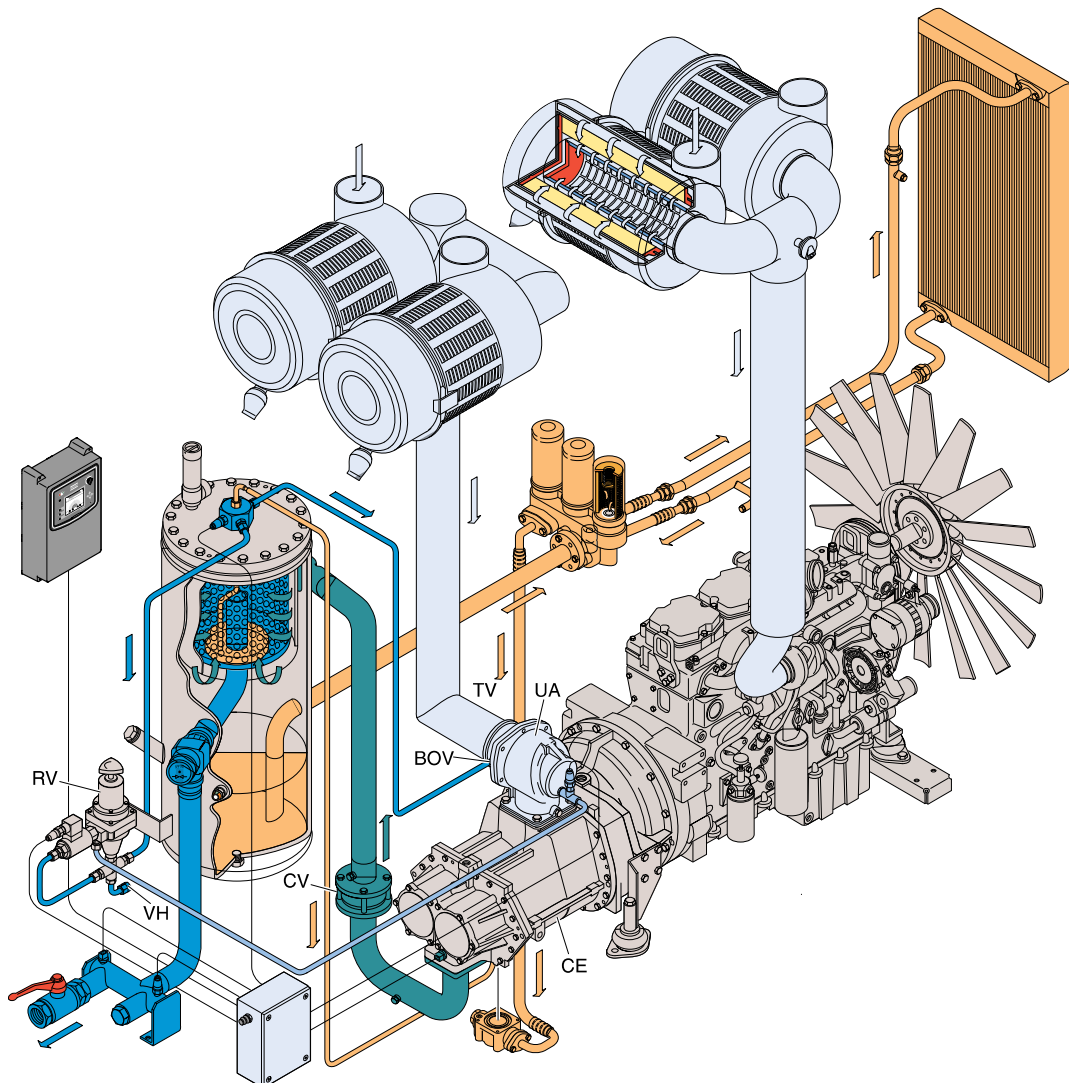

The compressor is provided with a continuous regulating system and a blow-off valve (BOV) which is integrated in the unloader assembly (UA). The valve is closed during operation by outlet pressure of the compressor element and opens by air receiver pressure when the compressor is stopped.

When the air consumption increases, the air receiver pressure will decrease and vice versa. This receiver pressure variation is sensed by the regulating valve (RV) which, by means of control air to the unloader assembly (UA), matches the air output to the air consumption. The air receiver pressure is maintained between the pre-selected working pressure and the corresponding unloading pressure.

When starting the compressor, the throttle valve (TV) is kept closed via receiver pressure. The compressor element (CEhp CElp) takes in air and pressure builds up in the receiver (AR). The throttle valve (TV) is closed. The air output is controlled from maximum output (100%) to no output (0%) by:

- 1 Speed control of the engine between maximum load speed and unloading speed (the output of a screw compressor is proportional to the rotating speed).
- 2 Air inlet throttling.

If the air consumption is equal to or exceeds the maximum air output, the engine speed is held at maximum load speed and the throttle valve (TV) is fully open.

If the air consumption is less than the maximum air output, air receiver pressure increases and the regulating valve supplies control air to throttle valve (TV) to reduce the air output and holds air receiver pressure between the normal working pressure and the corresponding unloading pressure. Unloading pressure = normal working pressure + 1 bar (14.504 psi).

When the air consumption is resumed, the blow off valve (BOV) closes and the throttle valve (TV) gradually opens the air intake and the electronic speed regulator increases the engine speed.

The construction of the regulating valve (RV) is such that any increase (decrease) of the air receiver pressure above the pre-set valve opening pressure results in a proportional increase (decrease) of the control pressure to the throttle valve and the electronic speed regulator.

Part of the control air is vented to atmosphere, and any condensate discharged, through the vent holes (VH).

2.5 Electric system

Circuit diagram (9822 0963 15 - Size 2 C9 LP)

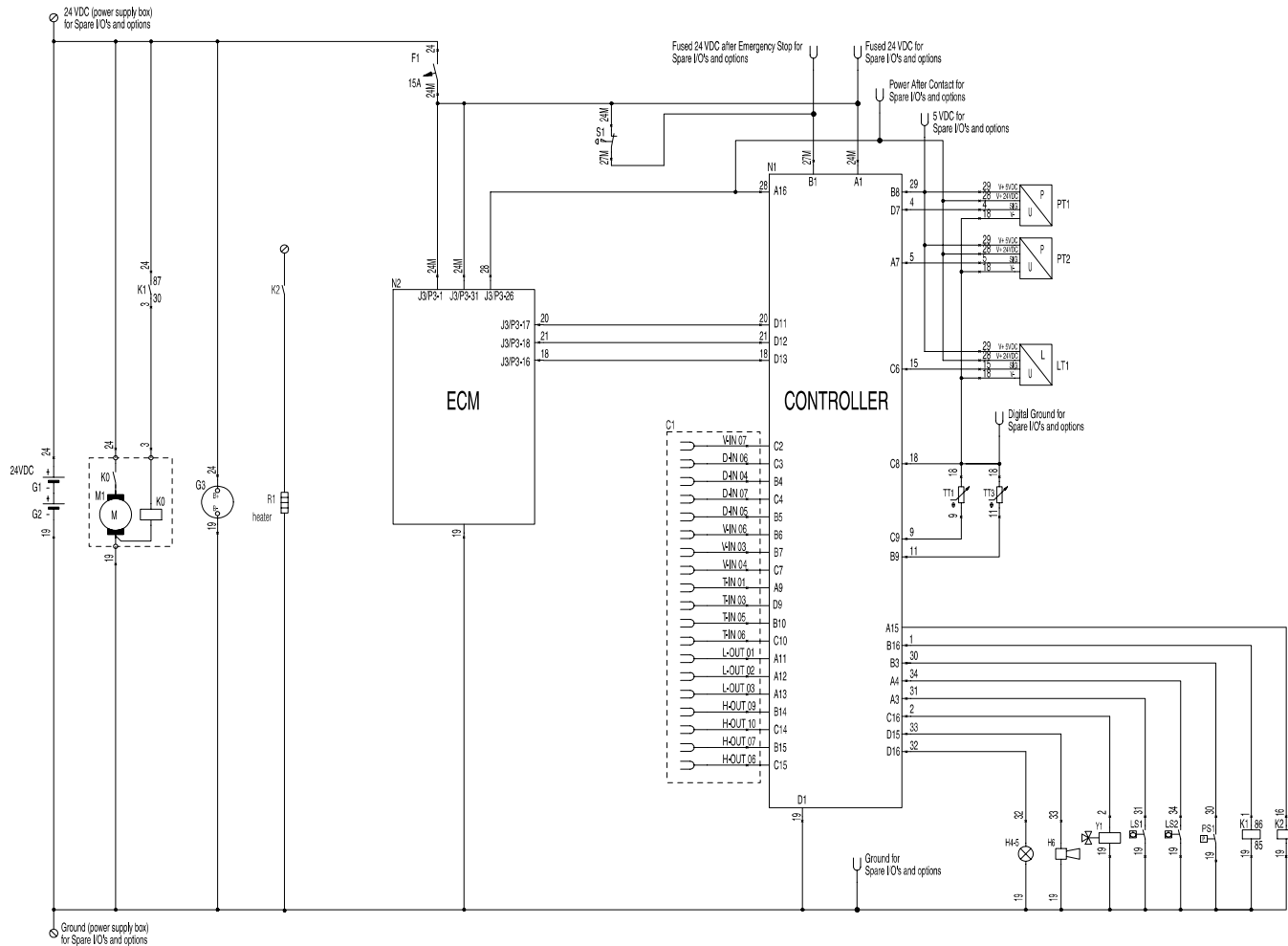

Reference	Name
C1	Spare I/O
F1	Fuse 15A
G1	Battery
G2	Battery
G3	Alternator
H4-5	Warning flasher lights
H6	Horn
K0	Relay Starter motor
K1	Relay Aux. starter
LS1	Level Switch, Coolant level warning
LS2	Level Switch, Coolant level shutdown
LT1	Level sensor, Fuel level

Reference	Name
M1	Starter motor
N1	Compressor Control Module
N2	Engine Control Module (Caterpillar)
PS1	Pressure Switch, Airfilter
PT1	Pressure sensor, Vessel Pressure
PT2	Pressure sensor, Regulating Pressure
S1	Emergency stop button
TT1	Temperature sensor, PT1000, LP Element temperature
TT3	Temperature sensor, PT1000, Ambient temperature
Y1	Loading Valve

2.6 Available options

Aftercooler package

An integral aftercooler, with water separator, is available to reduce the outlet air temperature to ambient plus 10°C and cut water content to a mere 15%. The installation includes a by-pass over the aftercooler.

Aftercooler package + fine filtration

For applications that demand quality air, a fine filtration unit can be specified with the aftercooler package. This will remove oil and particles down to 0.01 mg/m³.

Active charcoal filter package

For purer, but not breathing, air, an active charcoal filtration unit can be specified with the aftercooler package. This removes oil and oil vapour content to 0.003 mg/m³.

Refinery equipment

A combined certified spark arrestor and engine overrun protection package are available for use in applications in hazardous environments. In the event of engine overspeed, a pneumatically controlled solenoid valve closes off the air inlet and the fuel supply to the engine is cut.

Cold weather package

A cold weather package is available to facilitate operation in environments where temperatures go down to -25°C.

Forklift slots*

Fuel Xpert System

This is an electronic control module that regulates engine speed and the air inlet to optimise fuel consumption depending on the working conditions, and the output required.

3 Operating instructions

3.1 Parking, towing and lifting instructions

Safety precautions

	The operator is expected to apply all relevant 1 Safety precautions .
---	--

Attention

	<ul style="list-style-type: none">• Before putting the compressor in to use, check the brake system as described in section 5.5.1 Brake shoe adjustment (no ABS).• After the first 100 km travel: Check and retighten the wheel nuts and towbar bolts to the specified torque. See section 8.1 Torque values. Check the brake adjustment. See section 5.5.1 Brake shoe adjustment (no ABS).
---	---

3.1.1 Parking instructions

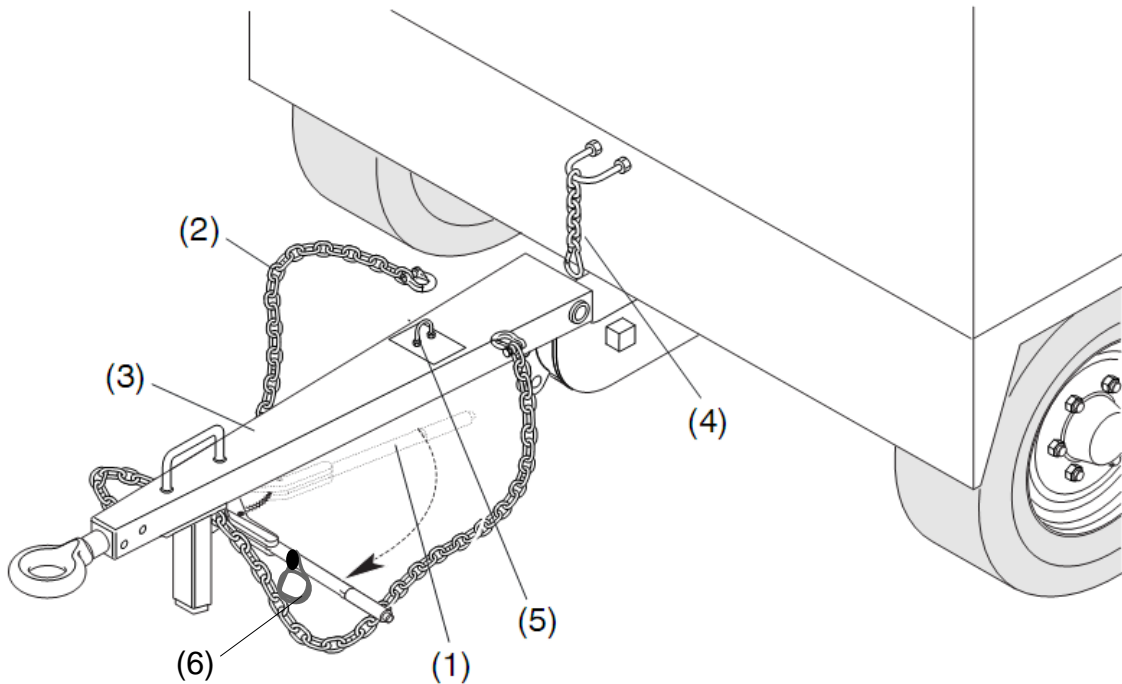

1. Apply parking brake by moving the lever (1) in the direction of the arrow.
2. Wind up the urgent brake cable (6);
3. Enlace and fix the safety chain (2) onto the towbar (3) or take the safety chain (2) away from the towbar (3);
3. Move the towbar (3) upwards and secure it by connecting the chain (4) to the eye (5).

Place the compressor as level as possible, however, it can be operated temporarily in an out-of-level position not exceeding 15° . If the compressor is parked on sloping ground, immobilize the compressor by placing wheel chocks (available as option) in front of or behind the wheels. Locate the rear-end of the compressor upwind, away from contaminated wind-streams and walls. Avoid recirculation of exhaust air from the engine. This can cause overheating and engine power decrease.

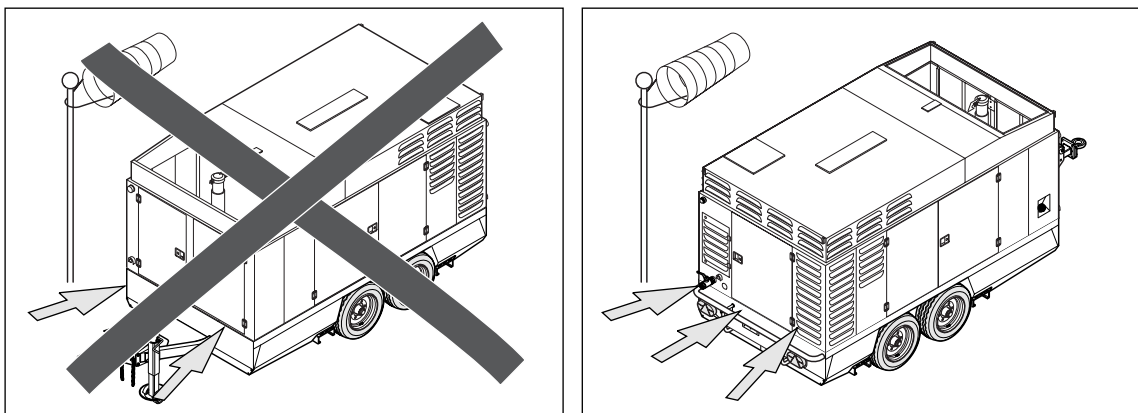

Rear-end of compressor upwind

3.1.2 Towing instructions

	<p>Before towing the compressor, ensure that the towing equipment of the vehicle matches the towing eye. The height of the towing device of the vehicle must be 815 - 845 mm (31.8 - 33 in).</p>
---	--

1. Attach the compressor to the towing vehicle
2. Move hand brake lever (1) in the direction of the arrow till stop and connect safety chain to the towing vehicle .
3. Connect the urgent brake cable to the vehicle.

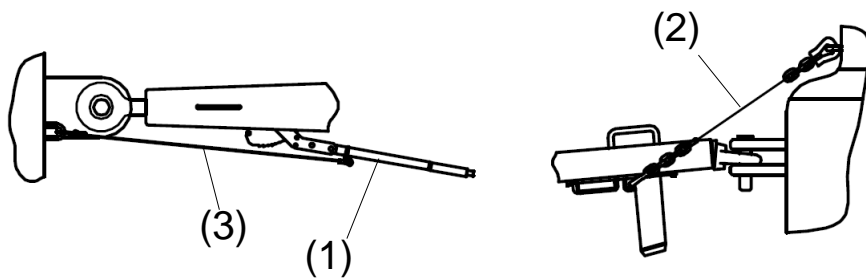
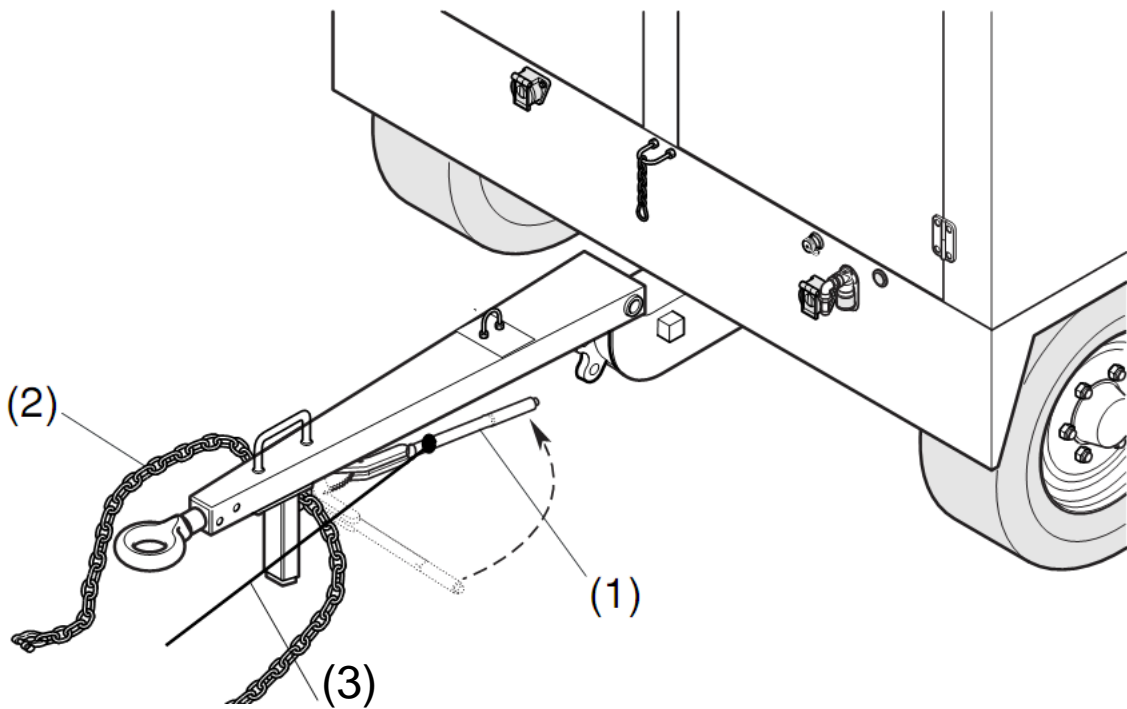

Towing position

Never move the compressor with air hoses connected to the air outlet valves.

	<p>Before moving the compressor, switch it off.</p>
---	---

3.1.3 Lifting instructions

To lift the compressor, use a lift truck or crane with sufficient capacity (weight: see indication on **9 Dataplate**).
See to it that the compressor will be lifted vertically and remains level.



Lifting acceleration and retardation must be kept within safe limits (max. 2xg). Helicopter lifting is not allowed.

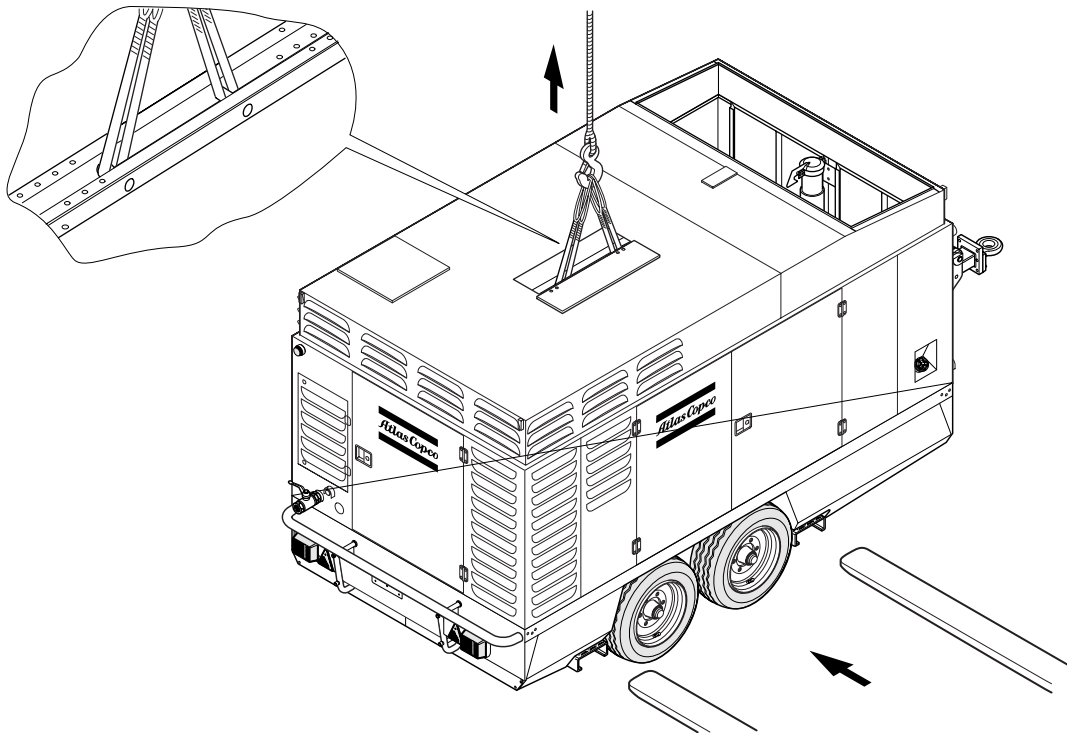

Lifting positions of unit

3.2 Before starting

Step	Action
1.	Before initial start-up, prepare battery for operation if not already done. See section 4.12.3 Recharging a battery .
2.	With the compressor standing level, check the level of the engine oil. Add oil, if necessary, to the upper mark on dipstick. Also check the engine coolant level. Consult the Engine Operation Manual for the type of coolant and type and viscosity grade of the engine oil.
3.	Remove the air receiver drain plug (DPar), see figure at step 10. , and open the valve to drain possible condensate. Close the valve when oil comes out and reinstall the drain plug. The interval between draining operations may be determined by experience, as the amount of condensate depends on the operating condition.

	Before draining, ensure that the pressure is released.
---	--

4.	Check the level of the compressor oil. See section 4.7.2 Check compressor oil level . The pointer of oil level gauge (OLG) should register in the green range. Add oil if necessary. See section 4.6.1 Synthetic compressor oil PAROIL S for the oil to be used.
----	--

	Before removing oil filler plug (FP), ensure that the pressure is released by opening an air outlet valve.
---	--

5.	Check that the fuel tank contains sufficient fuel. Top up, if necessary. Consult the Engine Operation Manual for the type of fuel.
6.	Drain any water and sediment from the fuel filters until clean fuel flows from the drain cock.
7.	Empty the dust trap of each air filter (AF). See section 5.2.3 Replacing the filter element and the safety cartridge .
8.	Clogged air filter(s) will be indicated on the display of the control panel, see section 3.3.8 Fault codes . If indicated, replace the filter elements.
9.	Check coolant level in engine coolant top tank integrated in radiator. Top up, if necessary. Consult the Engine Operation Manual for coolant specifications.

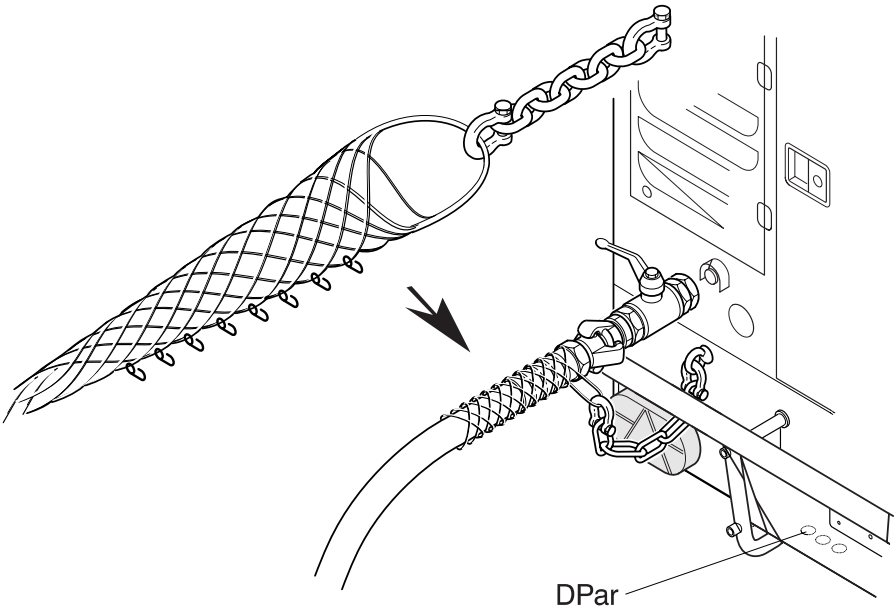
Step	Action
10.	<p>Attach the air line(s) to the closed air outlet valve(s). Connect the safety chain.</p> 

	<p>No external force may be applied to the air outlet valve(s), e.g. by pulling hoses or by connecting equipment directly to the valve(s).</p>
---	--

3.2.1 Specific start procedure

Follow this start procedure when the compressor is put in operation for the first time and after running out of fuel or changing the fuel filter.

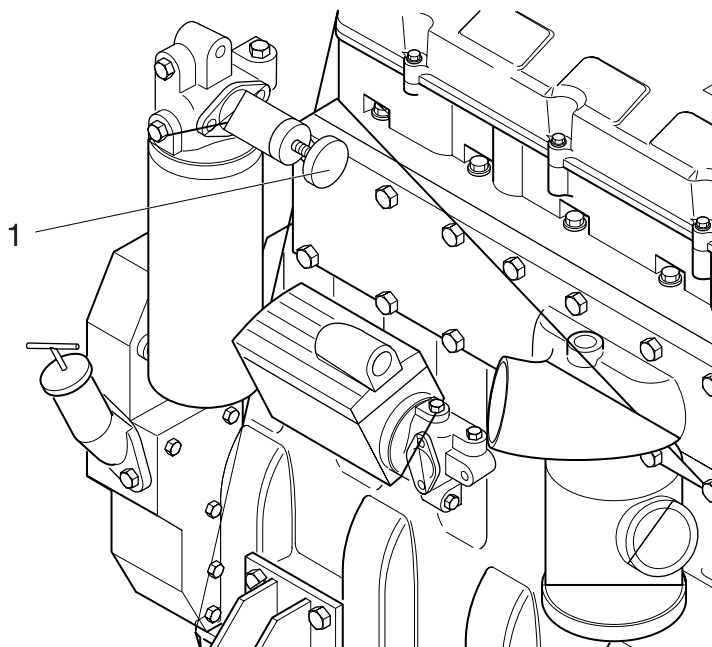

Fuel prefilter

- Operate the hand pump (1) at the prefilter until it is under pressure.
- Switch the “OFF/ON” switch to position ”ON”. The instrument panel will now perform a brief selftest.
- Push the start button and the starter motor will automatically try to start the engine..



After cleaning /draining the fuel tanks, the system is filled with air.
Before starting the engine operate the fuelpump on the fuelfilter to fill the fuelsystem.
Operate the pump until (1) the system is under pressure.
When under pressure the engine will start after approximately 10 seconds. If the system is not under pressure, it will take a few minutes until the engine will start.









3.3 Starting / Stopping

Safety precautions

	<p>Do not disconnect power supply to control box in any way when the control box is switched on. This will cause memory loss.</p> <p>Do not switch off the circuit breaker when the control box is switched on. This will cause memory loss.</p>
---	--

3.3.1 Control panel



Reference	Name
	<p>POWER OFF / ON switch</p> <p>To switch the control panel on and off</p>
	<p>START button</p> <p>Pressing this button will start the compressor.</p>
	<p>STOP button</p> <p>Pressing this button will stop the compressor in a controlled way.</p>
	<p>LOAD button. Pressing this button will:</p> <p>initiate the Auto Load function, or commands the compressor to load (depending on actual status).</p> <p>command the compressor to switch to Not Loaded (when in Load).</p>
	<p>MEASUREMENTS VIEW button</p> <p>By pressing this button you can toggle between Measurements View and Main View.</p>
	<p>SETTINGS VIEW button</p> <p>By pressing this button you can toggle between Settings View and Main View.</p>
	<p>ALARMS VIEW button</p> <p>By pressing this button you can toggle between Alarms View and Main View.</p>
	<p>NAVIGATION buttons</p> <p>These buttons are used to navigate through the display menu's.</p>
	<p>ENTER button</p> <p>Confirms/stores the selection/change.</p>

	<p>BACK button Moves back one level or ignores the change.</p>
---	--

3.3.2 Operations overview

It is possible to control the compressor locally with the Control Box, remotely with the remote switch inputs located on the back of the Control Box, or with software running on a PC with a CAN interface (PC Control Mode).

The way one ends up in each status can differ from how the Control Box is controlled, but the function of each status stays the same.

When reading this document, mind the difference between a status and a procedure. A status is a state in the Control Box's operation. A procedure is an action executed by the Control Box.

Example: The Stopping procedure is executed in the Stopping status, the Start Failure status and the Shutdown status.

During operation

	<p>The doors must be closed during operation and may be opened for short periods for inspection and adjustments only.</p>
---	---

Regularly carry out following checks:

That the regulating valve (RV) is correctly adjusted, i.e. starts decreasing the engine speed when reaching the preset working pressure in the receiver.

Check the air outlet temperature of the compressor element.

Check the engine oil pressure, the coolant temperature and display of control box.

Avoid the engine running out of fuel. Nevertheless, if this happens, fill the fuel tank and prime the fuel system to speed up starting (see section **3.3.4 Overview icons**).

3.3.3 Battery switch

Make sure the fuel tank is filled up when "INTERNAL FUEL" is selected.

	<p>Please be aware that the (optional) preheater unit is still "live" with the battery switch in "OFF" position.</p>
---	--

The compressor is equipped with a battery switch.

When the compressor is not in use this switch must always be in the "OFF" position.





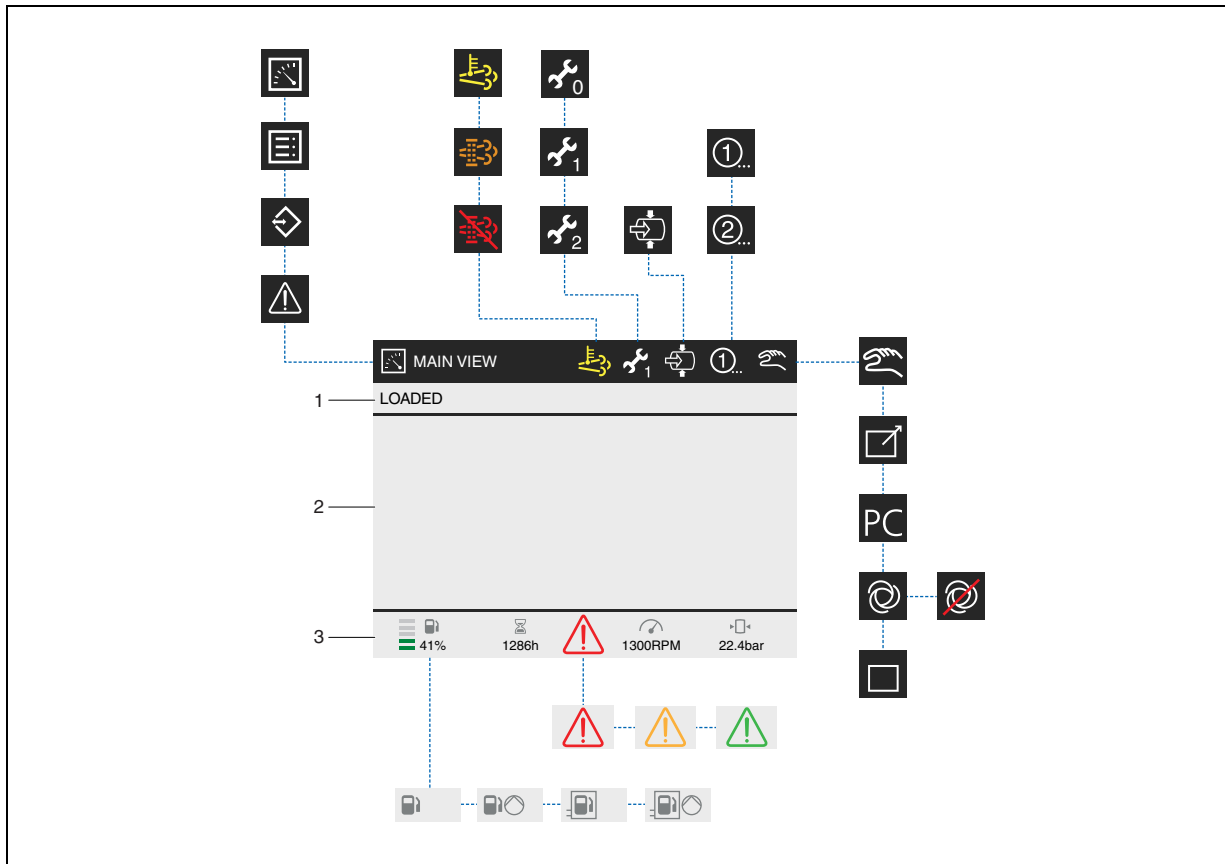

It is not allowed to use this switch as an emergency switch or for stopping the compressor. It will cause damage in the control unit when using this switch for stopping.

Always first shut off the control unit and wait until the display is dark before switching the battery switch to position "OFF".

	<p>Please be aware that the (optional) preheater unit is still "live" with the battery switch in "OFF" position.</p>
---	--

3.3.4 Overview icons



Reference	Name
1	Compressor status
2	Vessel pressure indication or info text
3	Compressor info
	Main View Indication
	Measuring View Indication
	Settings View Indication
	Alarm View Indication
	DPF REGENERATION High Exhaust System Temperature. Means that the Diesel Particle Filter is being regenerated.
	DPF REGENERATION NEEDED Means that the Diesel Particle Filter needs to be regenerated. Please force DPF Regeneration.
	DPF REGENERATION Diesel Particle Filter Regeneration Inhibited. Means that the DPF regeneration is inhibited, even if all criteria to activate a regeneration are met.

Reference	Name
	<p>DPF REGENERATION</p> <p>Diesel Particle Filter Regeneration Inhibited.</p> <p>Means that the DPF regeneration is inhibited, even if all criteria to activate a regeneration are met.</p>
	<p>OVERHAUL</p> <p>Initial Overhaul required.</p>
	<p>OVERHAUL</p> <p>Minor Overhaul required.</p>
	<p>OVERHAUL</p> <p>Major Overhaul required.</p>
	<p>AUTO LOAD</p> <p>This icon will be shown if the Auto Load functionality is enabled, or by means of a parameter setting, or by means of pressing the load button before the machine is ready to be loaded.</p>
	<p>PRESET</p> <p>Depending of which Pressure (and/or Flow) setting is active, the controller will show its dedicated icon.</p>
	<p>PRESET</p> <p>Depending of which Pressure (and/or Flow) setting is active, the controller will show its dedicated icon.</p>
	<p>OPERATION MODE</p> <p>Local</p>
	<p>OPERATION MODE</p> <p>Remote</p>
	<p>OPERATION MODE</p> <p>PC Control</p>
	<p>OPERATION MODE</p> <p>Automatic</p>
	<p>OPERATION MODE</p> <p>Automatic Mode is active, but the Auto Start and Auto Stop function are both inactive.</p>
	<p>OPERATION MODE</p> <p>Block Mode</p>
	<p>ALARM</p> <p>Active & not-acknowledged Shutdown Alarm.</p>
	<p>ALARM</p> <p>Active & not-acknowledged Non-Shutdown Alarm.</p>
	<p>ALARM</p> <p>Active & acknowledged Alarm.</p>
	<p>FUELTANK</p> <p>Running at internal fueltank.</p>
	<p>FUELTANK</p> <p>Running at internal fueltank & Fuelpump is energized.</p>
	<p>FUELTANK</p> <p>Running at external fueltank, but internal fueltank level is shown.</p>
	<p>FUELTANK</p> <p>Running at external fueltank, but internal fueltank level is shown & fuelpump is energized.</p>

3.3.5 Possible views

Main View

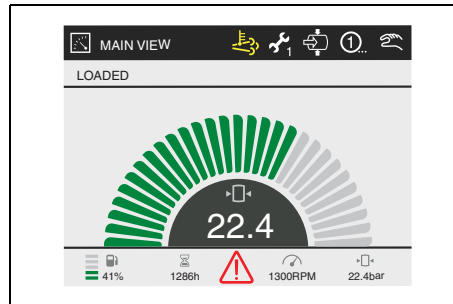

Measuring View

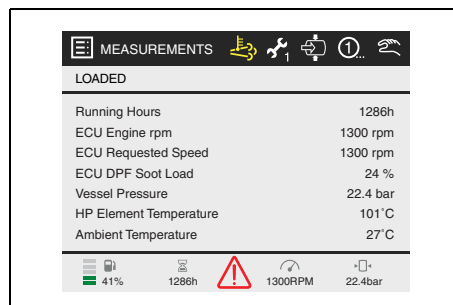

Use the Up and Down navigation buttons to scroll through the full list of measurements.
Setup View

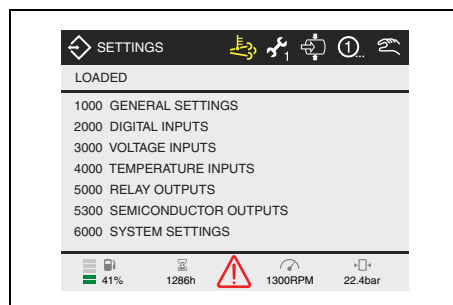

Use the Up and Down navigation buttons to scroll through the full list of settings.

Use the Enter button to enter the selected submenu.

Use the Back button to leave the entered (sub)menu.

Alarm View

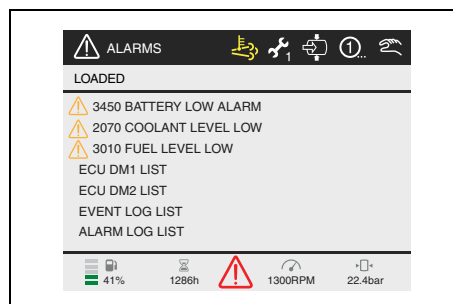

Use the Up and Down navigation buttons to scroll through the full list of alarms.

The DM Lists and the Log Lists can be selected and entered to access the sublist.

3.3.6 Starting

Switch on the battery switch.

Switch the controller on by switching the Power switch to the position “ON”.

The instrument panel will now perform a selftest; the following display will be shown and the controller is initialized:



During initializing all buttons/inputs/outputs/alarms are inactive.

This view will be shown for about 2 seconds, after which the display will show the Main View.

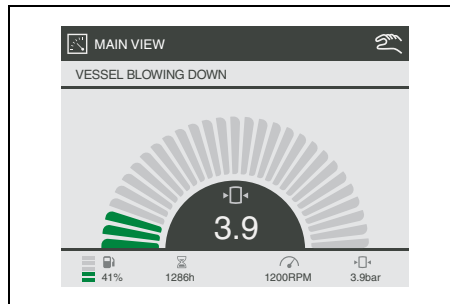

The actual vessel pressure is shown. If the measured vessel pressure is higher than 1.5 bar, the unit will not start. The vessel pressure has to be lowered by opening the blow down valve. After power up, the vessel pressure normally is low enough to proceed with the starting procedure.

	If the Power switch is turned to the “OFF” position while the vessel is blowing down, it will not power down for as long as the vessel pressure is higher than 1.5 bar.
--	---

Active Buttons	
	Measurement View Button
	Settings View Button
	Alarms View Button

The display now shows

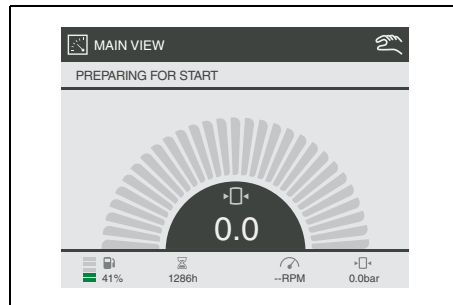

The machine is now ready to be started and is waiting for a start command.

Active Buttons	
	Start Button (to initiate Start command)
	Load Button (to activate Automatic Load)
	Measurement View Button
	Settings View Button
	Alarms View Button

The display now shows

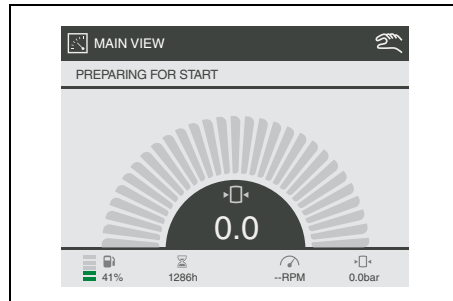

After pressing the START button the machine will activate its horn and flasher light for 5 seconds, to notify that it will start.

Active Buttons	
	Stop Button (to cancel Start command)
	Load Button (to activate Automatic Load)
	Measurement View Button
	Settings View Button
	Alarms View Button

The display now shows

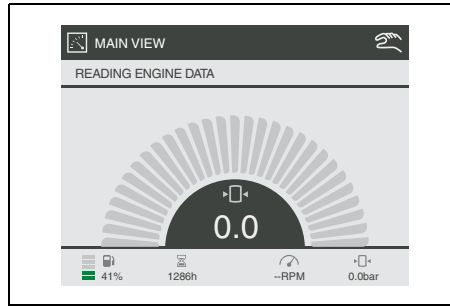

The engine electronics (ECU) will be powered up.

As soon as communication between compressor controller and engine controller is established, the machine will preheat according to the parameters of the engine controller.

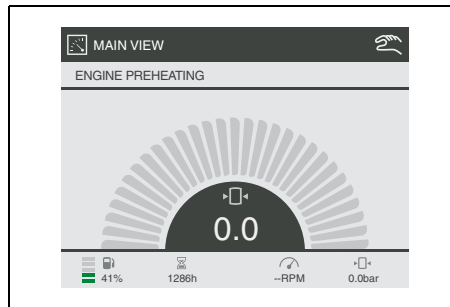

Active Buttons	
	Stop Button (to cancel Start command)
	Load Button (to activate Automatic Load)
	Measurement View Button
	Settings View Button
	Alarms View Button

The engine starts cranking, the display shows

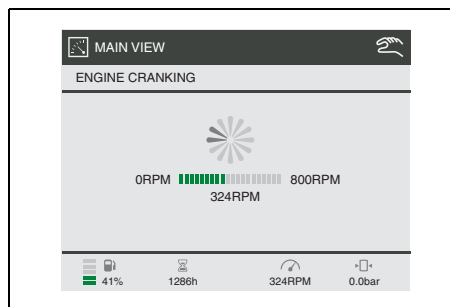



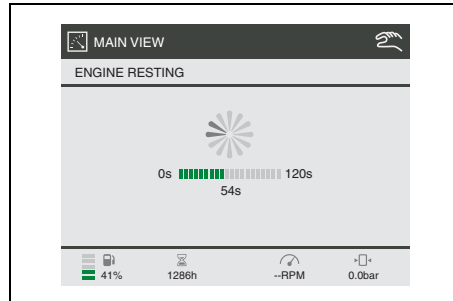

The engine cranks until 800 rpm is reached.

If 800 rpm is not reached within 30 seconds, the starting procedure is cancelled and the engine will rest for some time. (Resting time depends on cranking time).

The display now shows



Active Buttons	
	Stop Button (to cancel Start command)
	Load Button (to activate Automatic Load)
	Measurement View Button
	Settings View Button
	Alarms View Button

The engine starts running at idle speed. The display shows

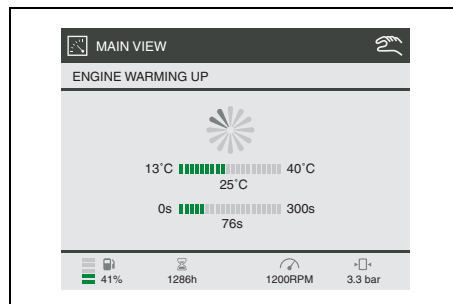

The engine will run at minimum rpm, until the engine's coolant temperature reaches 40°C, with a minimum time of 15 seconds and a maximum time of 300 seconds.

The display now shows

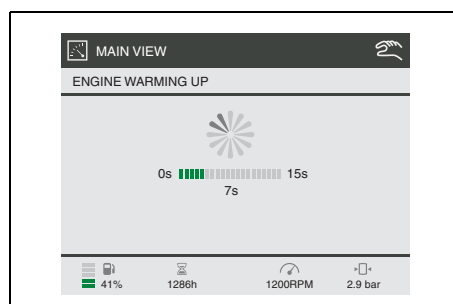

Active Buttons	
	Stop Button (to cancel Start command)
	Load Button (to activate Automatic Load)
	Measurement View Button
	Settings View Button
	Alarms View Button

After warming up the machine is ready to be loaded and is waiting for a load command; the display shows

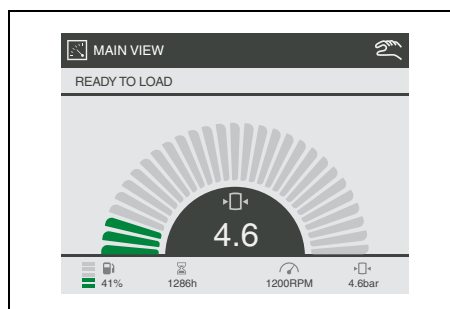



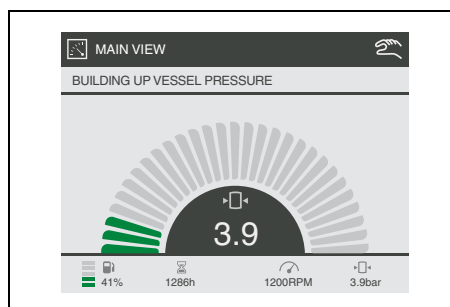

Active Buttons	
	Stop Button (to cancel Start command)
	Load Button (to initiate Automatic Load)
	Measurement View Button
	Settings View Button
	Alarms View Button

Press the load button, the display will show





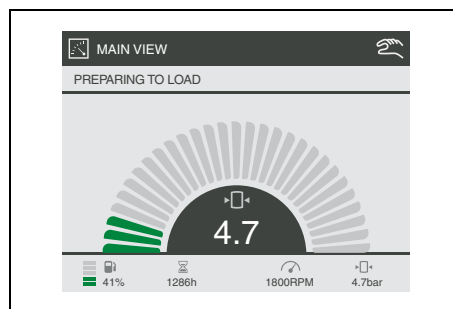

When the load button is pressed and the measured vessel pressure is lower than 4.5 bar, the controller will run a specific program to reach the requested 4.5 bar, in order to be able to load the machine. **(Only applicable for 2-stage machines).**

Active Buttons	
	Stop Button (to cancel Start command)
	Load Button (to cancel Load command)
	Measurement View Button
	Settings View Button
	Alarms View Button

The engine will now run at maximum rpm, the display will show



The loading valve will be energized and pressure starts building up.

Active Buttons	
	Stop Button (to cancel Start command)
	Load Button (to cancel Load command)
	Measurement View Button
	Settings View Button
	Alarms View Button

During loading the following display is shown (default display)

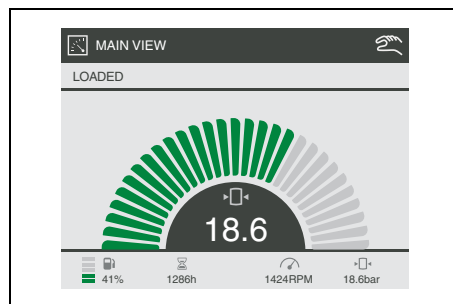

The controller controls the speed of the engine in order to meet the requested working pressure, at the most economical fuel usage.

Active Buttons	
	Stop Button (to cancel Start command)
	Load Button (to cancel Load command)
	Measurement View Button
	Settings View Button
	Alarms View Button

During operation

	The doors must be closed during operation and may be opened for short periods for inspection and adjustments only.
--	--

	Be aware not to touch hot parts when the door is open.
--	--

	When the engine is running, the air outlet valves (ball valves) must always be put in a fully opened or fully closed position.
--	--

Regularly carry out following checks:

- Ensure that the regulating valve (RV) is correctly adjusted, i.e. starts decreasing the engine speed when reaching the preset working pressure in the receiver.
- Check the air outlet temperature of the compressor element.
- Check the engine oil pressure, the coolant temperature and display of control box.
- Avoid the engine running out of fuel. Nevertheless, if this happens, fill the fuel tank and prime the fuel system to speed up starting.

Set the Pressure/Flow Setpoint

When the controller is in the Main View (shift between PRESSURE and FLOW VIEW with right/left arrows):

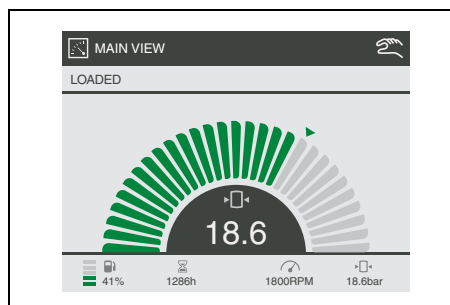

Press ENTER for 2 seconds, and the middle section becomes green (setting can be edited)

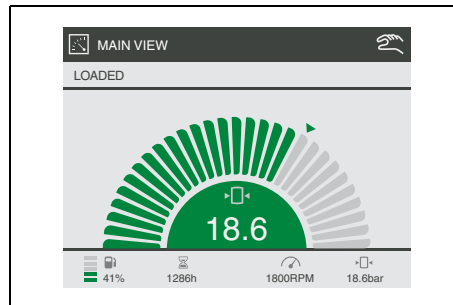

Press the UP/DOWN arrows to set the requested pressure/flow.

Press ENTER to confirm the new setting.

Some additional control features are available from Atlas Copco, such as dual pressure switch, remote start, auto start, remote pressure setting. If interested, please consult your Atlas Copco representative for more information.

3.3.7 Stopping

After pressing the STOP button the display will show:

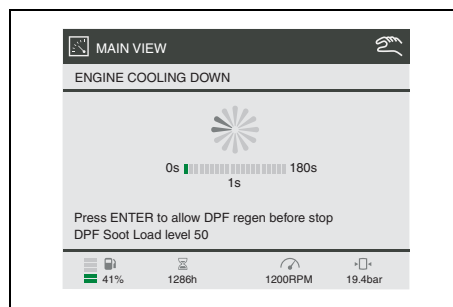

After a Stop command, or in case of a controlled stop alarm, the machine will cool down and run at minimum rpm for 3 minutes before it will stop.

If the Soot Load in the diesel particulate filter is above 30% when a stop command is given, the controller will ask the user if it is allowed to perform a complete DPF Regeneration cycle before stopping.

	<p>A full DPF Regeneration can take up to an hour..</p>
--	---

When ENTER is pressed the HEST icon will appear:

	<p>HEST Icon</p>
--	------------------

See paragraph **ALWAYS FIRST SHUT OFF THE CONTROLLER AND WAIT UNTIL THE DISPLAY IS DARK BEFORE SWITCHING THE BATTERY SWITCH TO POSITION “OFF”.DIESEL PARTICULATE FILTER REGENERATION.**

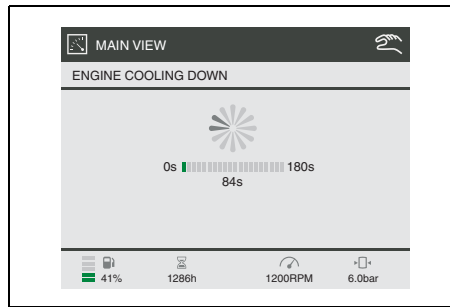

Active Buttons	
	Start Button (to initiate Start command)
	Measurement View Button
	Settings View Button
	Alarms View Button

After cooling down the engine will stop and the display will show

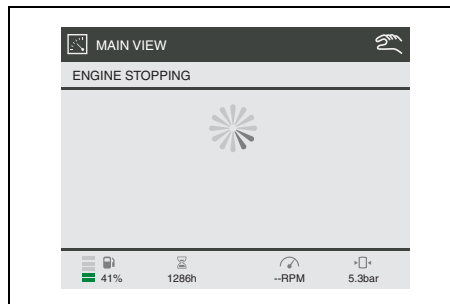





The engine is stopped, and the controller will do a double check to see if the engine is really stopped.

Active Buttons	
	Start Button (to initiate Start command)
	Measurement View Button
	Settings View Button
	Alarms View Button

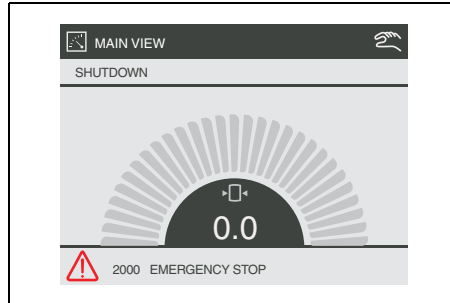
3.3.8 Shutdown

When the machine is shutdown due to a critical alarm or an emergency stop the display will show



Active Buttons	
	Measurement View Button
	Settings View Button
	Alarms View Button
	Enter Button (to acknowledge the shown alarm)

3.3.9 Power off

Switch the controller off by switching the Power switch to the position “OFF”.

The compressor is equipped with a battery switch.

When the compressor is not in use, this switch must always be in the “OFF” position.

It is not allowed to use this switch as an emergency switch or for stopping the compressor.

It can damage the controller or the engine’s Electronic Control Unit when using the battery switch for stopping.

Always first shut off the controller and wait until the display is dark before switching the battery switch to position “OFF”. Diesel Particulate Filter Regeneration

3.3.10 DIESEL PARTICULATE FILTER REGENERATION

When the Diesel Particle Filter regeneration process is kept at its default ‘AUTOMATIC’ setting, then the DPF regeneration will be performed automatically when the Soot Load exceeds 60%.

The controller display will indicate an ongoing DPF Regeneration by showing the HEST icon (High Exhaust System Temperature):

	HEST Icon
---	-----------

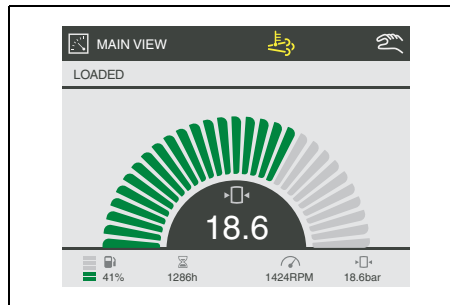

The DPF regeneration process will continue, until the Soot Load has become as low as possible, or until the engine is stopped.

When the DPF regeneration process is stopped, the HEST icon will disappear from the display.

Automatic DPF Regeneration (Default)

In specific cases, when the engine speed is constant at Minimum RPM, it can happen that the DPF regeneration already starts from 30% Soot Load (LSR - Low Speed Regeneration).

This can happen in following situations:

- Warming Up
- Not Loaded
- Loaded (when running in Unload condition - minimum RPM)
- Cooldown

When an LSR is ongoing while the soot load is less than 60%, and the engine speed changes (engine is stopped, machine gets loaded, ...), then the DPF Regeneration process will be stopped.

If the Soot Load is higher than 30% when cooling down should start (then an LSR is expected to be started) the controller will ask:

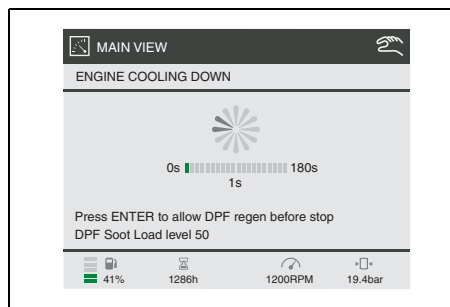

If Enter is pressed within 10 seconds then the controller will allow the DPF regeneration to be completed before the engine is stopped.

	<p>A full DPF Regeneration can take up to an hour.</p>
--	--

If Enter is not pressed (within 10 seconds), then the engine will be stopped after cooling down.

Inhibit DPF Regeneration

When running in an environment where an elevated exhaust temperature is not allowed, it might be necessary to inhibit DPF regeneration. This has to be done at Service Level. The controller has now put the DPF Regeneration in a FORCED OFF mode, which is Inhibit DPF Regeneration.

The compressor controller will communicate with the engine controller and the (RED) Inhibit DPF regeneration icon will appear:



DPF Regeneration Inhibited

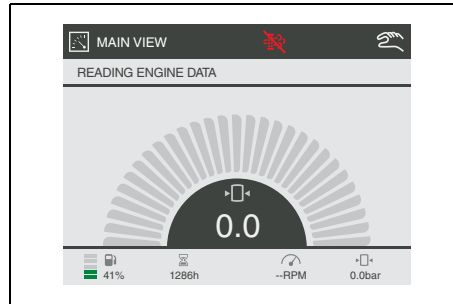

When the controller gets powered down, it will (at next power up) fall back to its default settings, meaning AUTOMATIC DPF regeneration.

Increasing Soot Load

When the DPF Regeneration is Inhibited, or when the engine does not get sufficient possibility to automatically perform a full DPF Regeneration, the Soot Load will exceed the normal levels.

The controller will show the DPF Regeneration Needed Icon. In case of Inhibited DPF Regeneration, the DPF Regeneration Needed Icon will overwrite the DPF Inhibited Icon.

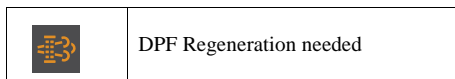

DPF Regeneration needed

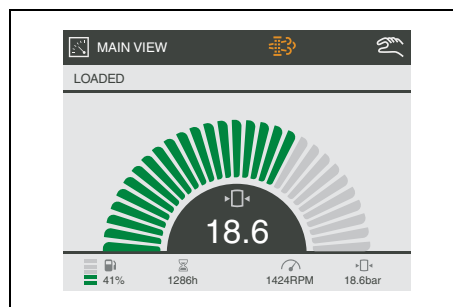

Required Action:

- Force DPF Regeneration, see paragraph **FORCE DPF REGENERATION**

When DPF Regeneration is started, the DPF Regeneration Needed icon will disappear and the HEST icon will pop-up.

SOOT LOAD reaches 90% (only when DPF Regeneration is Inhibited)

When still no DPF regeneration is forced the next warning alarm will pop-up:

	DPF Regeneration needed
--	-------------------------

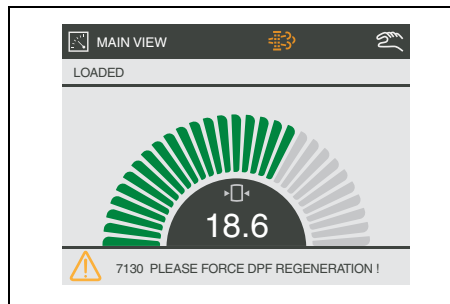

Required Action:

- Acknowledge the ‘PLEASE FORCE DPF REGENERATION !’ warning (press Enter while in the Main View).
- Force DPF Regeneration, see paragraph **FORCE DPF REGENERATION**

When DPF Regeneration is started, the DPF Regeneration Needed icon will disappear and the HEST icon will pop-up.

SOOT LOAD reaches 92%

When still no DPF regeneration is forced the next warning alarm will pop-up.

Additionally the machine will be prevented to Load:

	DPF Regeneration needed
--	-------------------------

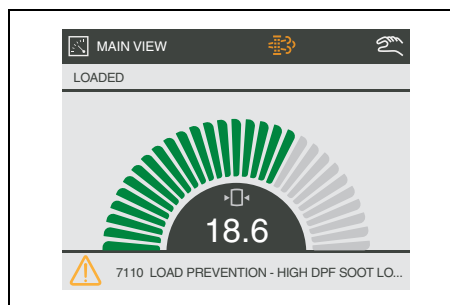

Required Action:

- Acknowledge the ‘LOAD PREVENTION - HIGH DPF SOOT LOAD’ inhibit load alarm (press Enter while in the Main View).
- Force DPF Regeneration, see paragraph **FORCE DPF REGENERATION**

When a DPF Regeneration is started, the DPF Regeneration Needed icon will disappear and the HEST icon will pop-up.

SOOT LOAD reaches 98%

When no DPF regeneration is forced, the controller will force the machine into Not Loaded.

	DPF Regeneration needed
--	-------------------------

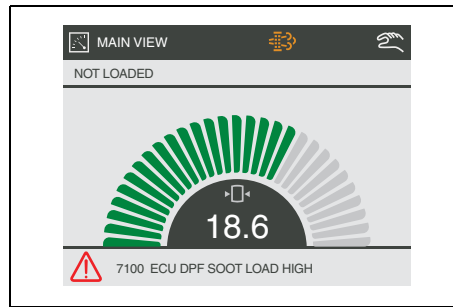

Required Action:

- Acknowledge the ‘ECU DPF SOOT LOAD HIGH’ warning (press Enter while in the Main View).
- Force DPF Regeneration, see paragraph **FORCE DPF REGENERATION**

When DPF Regeneration is started, the DPF Regeneration Needed icon will disappear and the HEST icon will pop-up.

SOOT LOAD reaches 101%

If still no action is taken the following warning appears and the controller will perform a controlled shutdown.

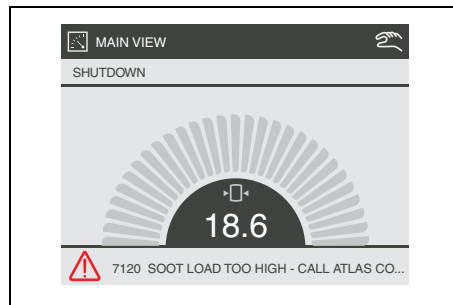

As soon as the engine is stopped, the DPF Regeneration Needed icon will disappear (engine electronics are powered down).

	Contact Atlas Copco for further actions to be taken.
---	--

Force DPF Regeneration

If DPF Regeneration is Inhibited

Machine is not running:

Power the controller down. At next power up, the DPF Regeneration settings will be back to default, and an Automatic DPF Regeneration will take place at the soonest appropriate moment.

Machine is running:

- Press the Settings View Button
- Enter the ‘1000 GENERAL SETTINGS’ menu
- Scroll one line down and Enter the ‘1140 ECU DPF REGENERATION’ menu

OR

- Scroll down and Enter the 'MODE' parameter
- Scroll down and Enter the 'AUTOMATIC' setting
- Press the Back button 3 times to get back to the Main View

DPF Regeneration setting will now be AUTOMATIC DPF REGENERATION.

Customer Level can now select between AUTO Regeneration & INHIBIT Regeneration, as long as the controller is not powered down (after power down, it will fall back to its default DPF Regeneration settings, and a Service Level is needed to go back to Inhibit DPF Regeneration).

3.3.11 Settings

For buttons to be used see "Control Panel"

Acknowledge an Alarm

If an alarm becomes active, for example a Low Fuel Level Warning:

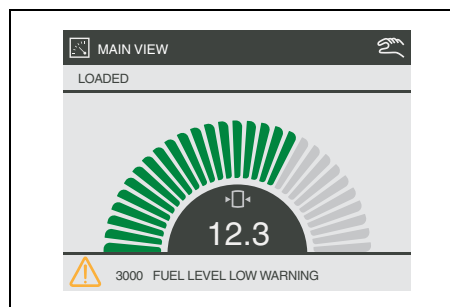

then this alarm can be acknowledged by pressing the ENTER button. If the fuel level is still low, the view will change to:

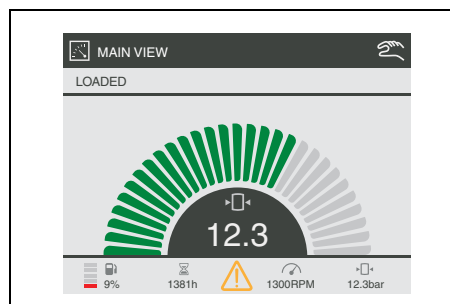

As soon as the fuel level is higher than the warning level, the alarm icon will automatically disappear.

As long as there is an alarm icon in the middle of the bottom part of the view, all active acknowledged / un-acknowledged alarms can be seen by pressing the ALARM VIEW button

Pressing the ALARM VIEW button again, will bring you back to the Main View.

Set Clock

Press the SETTINGS VIEW button

- scroll to '1000 GENERAL SETTINGS'

- press ENTER
- scroll to '1290 DATE/TIME'
- ENTER the Date/Time menu
- scroll to the parameter you want to change
- ENTER this parameter.

To change the 'RTC Month', scroll to the preferred month and press ENTER.

To change any other RTC setting, the red figure is editable.

Scroll up/down and press ENTER to change. Use left/right to shift between editable figures.

Now press BACK until you're back in the Main View (or in the menu you require).

Set Language

Press the SETTINGS VIEW button.

- scroll to '1000 GENERAL SETTINGS'
- press ENTER
- scroll to '1300 LANGUAGES'
- ENTER the LANGUAGES menu,
- ENTER the 'SETTINGS' parameter
- scroll to the preferred language
- press ENTER.
- Now press BACK until you're back in the Main View (or in the menu you require).

Set Units

Press the SETTINGS VIEW button,

- scroll to '1000 GENERAL SETTINGS'
- press ENTER
- scroll to the unit you would like to change:
 - '1340 TEMPERATURE UNITS'
 - '1350 PRESSURE UNITS'
 - '1360 FUEL FLOW UNITS'
 - '1370 AIR FLOW UNITS'
- ENTER the preferred menu
- ENTER the 'SETTINGS' parameter
- scroll to the preferred setting

- press ENTER.

Now press BACK until you're back in the Main View (or in the menu you require).

Change Display Settings

Press the SETTINGS VIEW button

- scroll to '1000 GENERAL SETTINGS'
- press ENTER
- scroll to '1310 DISPLAY BACKLIGHT'
- ENTER the DISPLAY BACKLIGHT menu
- scroll to the setting you would like to change
- press ENTER.

To change a setting, the red figure is editable.
 Scroll up/down and press ENTER to change. Use left/right to shift between editable figure.
 Now press BACK until you're back in the Main View (or in the menu you require).

Go To Diagnostics

Press the SETTINGS VIEW button

- scroll to '1000 GENERAL SETTINGS'
- press ENTER
- scroll to '1150 DIAGNOSTICS'
- ENTER the Diagnostics menu,
- ENTER the 'ENABLE' parameter
- scroll to 'ON' and press ENTER.

Now the ECU will get PAC (ignition) and one can perform ECU diagnostics (read DM1 List, DM2 List, ECU values, perform engine diagnostics, ...).

Now press BACK until you're back in the Main View (or in the menu you require).

To leave Diagnostics, press the STOP button.

3.3.12 Fault codes

There are several parameters that are continuously watched.

When one of these parameters exceeds its specified limit the compressor will react depending the present status of the control box.

Alarmcode	Alarmtext	Failclass	Trigger
1231	FUEL FILL CHECK	Warning	Xc

Alarmcode	Alarmtext	Failclass	Trigger
1503	INITIAL OVERHAUL REQUIRED	Warning	Xc
1522	MINOR OVERHAUL WITHIN ** H	Warning	Xc
1523	MINOR OVERHAUL WITHIN ** D	Warning	Xc
1524	MINOR OVERHAUL REQUIRED	Warning	Xc
1552	MAJOR OVERHAUL WITHIN ** H	Warning	Xc
1553	MAJOR OVERHAUL WITHIN ** D	Warning	Xc
1554	LOAD PREVENTION - FIRE RISK	Inhibit Load	Xc
1558	COMP. OIL CHANGE WITHIN ** H	Warning	Xc
1559	COMP. OIL CHANGE WITHIN ** D	Warning	Xc
2000	EMERGENCY STOP INPUT	Shutdown	Xc
2040	REMOTE EMERGENCY STOP	Shutdown	Xc
2070	COOLANT LEVEL LOW WARNING	Warning	Xc
2080	COOLANT LEVEL LOW SHUTDOWN	Shutdown	Xc
2090	ΔP AIRFILTERS HIGH	Warning	Xc
2100	NO PROJECTFILE DOWNLOADED	Warning	Xc
2752	NAM OILTRONIX BYPASS CIRCUIT	Shutdown After Stop	Xc
2762	NAM OILTRONIX CLOSED CIRCUIT	Shutdown After Stop	Xc
2772	NAM AIRXPRT OPENED CIRCUIT	Shutdown	Xc
2782	NAM AIRXPRT CLOSED CIRCUIT	Shutdown	Xc
3000	FUEL LEVEL LOW WARNING	Warning	Xc
3010	FUEL LEVEL LOW SHUTDOWN	Controlled Stop	Xc
3020	FUEL LEVEL SENSOR CIRCUIT	Warning	Xc
3050	VESSEL PRESSURE HIGH WARNING	Controlled Stop	Xc
3060	VESSEL PRESSURE HIGH SHUTDOWN	Shutdown	Xc
3070	VESSEL PRESSURE SENSOR CIRCUIT	Shutdown	Xc
3120	REGULATING PRESSURE SENSOR CIRCUIT	Shutdown	Xc
3170	AIR DISCHARGE PRESSURE SENSOR CIRCUIT	Warning	Xc
3320	INLET PRESSURE SENSOR CIRCUIT	Shutdown	Xc
3450	BATTERY LOW ALARM	Indication	Xc
3460	BATTERY HIGH ALARM	Warning	Xc
3660	FIRE RISK - CHECK OILSTOPVALVE	Shutdown	Xc
3680	OSV PRESSURE SENSOR CIRCUIT	Controlled Stop	Xc
3720	INTERSTAGE PRESSURE SENSOR CIRCUIT	Warning	Xc
4000	L.P. ELEMENT TEMPERATURE HIGH	Warning	Xc
4010	L.P. ELEMENT TEMP. ALARM 2	Controlled Stop	Xc
4020	L.P. ELEMENT TEMP. ALARM 3	Shutdown	Xc
4040	L.P. ELEMENT TEMP. SENSOR CIRCUIT	Shutdown	Xc
4070	AMBIENT TEMPERATURE SENSOR CIRCUIT	Warning	Xc
4100	AIR DISCHARGE TEMPERATURE ALARM 1	Warning	Xc
4110	AIR DISCHARGE TEMPERATURE ALARM 2	Controlled Stop	Xc
4120	A.D. TEMPERATURE SENSOR CIRCUIT	Warning	Xc
4150	H.P. ELEMENT TEMPERATURE ALARM 1	Warning	Xc
4160	H.P. ELEMENT TEMPERATURE ALARM 2	Controlled Stop	Xc
4170	H.P. ELEMENT TEMPERATURE ALARM 3	Shutdown	Xc
4190	H.P. ELEMENT TEMP. SENSOR CIRCUIT	Shutdown	Xc
4220	AFTERCOOLER AIR TEMP SENSOR CIRCUIT	Warning	Xc
4230	AFTERCOOLER FREEZING DANGER	Indication	Xc
5200	AIR SHUT OFF	Shutdown	Xc
6190	CHARGE MONITORING FAIL	Indication	Xc
6327	START FAILURE	Shutdown	Xc
6329	STARTER SPEED TOO LOW	Shutdown	Xc
6388	VESSEL PRESSURE TOO LOW TO LOAD	Indication	Xc
6426	UNINTENTIONAL RUN	Shutdown	Xc
6427	RUN FAILURE	Shutdown	Xc
6428	STOP FAILURE	Shutdown	Xc
6708	DRAINING 1	Warning	Xc
6709	DRAINING 2	Warning	Xc
6749	OILTRONIX FUNCTIONALITY DISABLED	Warning	Xc
6760	OILTRONIX COUPLING FAILURE	Shutdown After Stop	Xc
6769	OILTRONIX COMPONENT FAILURE	Shutdown	Xc
6981	INLET VALVE POS. FAILURE	Shutdown	Xc
7002	ECU COMMUNICATION	Shutdown	Xc
7007	ECU RED LAMP	Shutdown	ECU
7008	ECU AMBER LAMP	Warning	ECU
7009	ECU PROTECT LAMP	Warning	ECU
7010	ECU ENGINE SPEED TOO LOW	Shutdown	Xc
7020	ECU ENGINE SPEED ALARM 2	Shutdown	Xc

Alarmcode	Alarmtext	Failclass	Trigger
7030	ECU ENGINE COOLANT TEMP. ALARM	Controlled Stop	Xc
7050	ECU ENGINE AIR INLET TEMP. ALARM 1	Controlled Stop	Xc
7100	ECU DPF SOOT LOAD HIGH	Warning	Xc
7110	PLEASE FORCE DPF REGENERATION !	Inhibit Load	Xc
7120	LOAD PREVENTION - HIGH DPF SOOT LOAD	Controlled Stop	Xc
7130	SOOT LOAD TOO HIGH - CALL ATLAS COPCO	Warning	Xc
7222	COMBO COMMUNICATION FAILURE	Warning	Xc
7223	COMBO PA SENSOR WARNING	Warning	Xc
7224	COMBO RHA SENSOR WARNING	Warning	Xc
7225	COMBO TA SENSOR WARNING	Warning	Xc

Details of ECU triggered alarms can be monitored via the ECU DM1 LIST menu

In case of ECU AMBER LAMP or ECU PROTECT LAMP:

Only possible when engine is running or if Diagnostics Mode is active.

Access the ECU DM1 LIST menu via Alarm View.

In case of ECU RED LAMP:

Do NOT acknowledge the ECU RED LAMP alarm.

DM1 alarms are automatically copied into the Alarm View, and can be read there.

For all ECU triggered alarms, the respective SPN code is shown in the ECU DM1 LIST

A full list of supported SPN codes is provided by the engine manufacturer.

For following alarms, the Xc controller also shows full text next to the SPN code:

ECU - FUEL FILTER PRESSURE

ECU - INTERCOOLER TEMPERATURE

ECU - FUEL PRESSURE

ECU - FUEL FILTER PRESSURE

ECU - WATER IN FUEL

ECU - OIL LEVEL

ECU - OIL FILTER PRESSURE

ECU - OIL PRESSURE

ECU - TURBO BOOST PRESSURE

ECU - TURBO OIL PRESSURE

ECU - INTAKE MANIFOLD TEMPERATURE

ECU - AIR INLET PRESSURE

ECU - COOLANT TEMPERATURE

ECU - COOLANT LEVEL

ECU - SUPPLY VOLTAGE

ECU - AMBIENT AIR TEMPERATURE

ECU - AIR INLET TEMPERATURE

ECU - FUEL TEMPERATURE

ECU - OIL TEMPERATURE
ECU - ENGINE SPEED
ECU - INJECTOR 1
ECU - INJECTOR 2
ECU - INJECTOR 3
ECU - INJECTOR 4
ECU - INJECTOR 5
ECU - INJECTOR 6
ECU - INJECTOR 7
ECU - INJECTOR 8
ECU - SOOT LOAD

3.3.13 Emergency stop

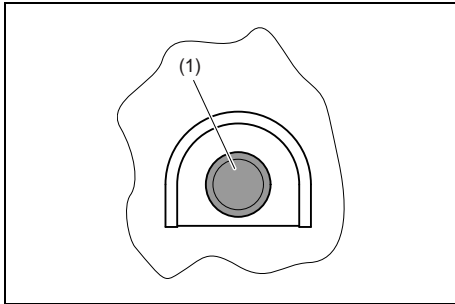

The emergency stop button is only to be used in emergency situations; not for stopping procedures.

When an emergency stop button (1) is pressed, power to all outputs is terminated, by the emergency stop itself (hardware) as well as by the software.

When the emergency stop button (1) is pressed the operator can unlock the emergency stop by turning it counterclockwise.

4 Maintenance

4.1 Liability

The manufacturer does not accept any liability for any damage arising from the use of non-original parts and for modifications, additions or conversions made without the manufacturer's approval in writing.

4.2 Service paks

A Service Pak is a collection of parts to be used for a specific maintenance task, e.g. after 50, after 200 and after 1000 running hours.

It guarantees that all necessary parts are replaced at the same time keeping down time to a minimum.

The order number of the Service Paks are listed in the Atlas Copco Parts List (ASL).

Use of service paks

Service Paks include all genuine parts needed for normal maintenance of both compressor and engine.

Service Paks minimize downtime and keep your maintenance budget low.

Order Service Paks at your local Atlas Copco dealer.

4.3 Service kits

A service kit is a collection of parts to fit a specific repair or rebuilding task.

It guarantees that all necessary parts are replaced at the same time which improves the uptime of the unit.

The order numbers of the Service Kits are listed in the Atlas Copco Parts List (ASL).

	<p>Contact Atlas Copco.</p>
---	-----------------------------

4.4 Storage

Run the compressor regularly, e.g. twice a week, until warm.

Load and unload the compressor a few times to operate the unloading and regulating components. Close the air outlet valves after stopping.

	<p>If the compressor is going to be stored without running from time to time, protective measures must be taken.</p>
---	--

4.5 Preventive maintenance schedule for the compressor

The schedule contains a summary of the maintenance instructions. Read the respective section before taking maintenance measures.



When servicing, replace all disengaged packings, e.g. gaskets, O-rings, washers.

For engine maintenance refer to Engine Operation Manual.

The maintenance schedule has to be seen as a guideline for compressors operating in a dusty environment typical to compressor applications. Maintenance schedule can be adapted depending on application, environment and quality of maintenance.

Maintenance schedule	Daily		Every 6 months	Yearly
		50 hours after initial start-up	or every 250 hours	or every 1000 hours
XMS1150 □ XTS1050 XHS950 XVS900		supplied with unit	1092 0583 02 1092 0583 02	1092 0614 95 1092 0614 09
Engine oil level	Check			
Condensate (11)	Drain			
Compressor oil level	Check			
Coolant level	Check			
Air filter vacuator valves	Empty			
Fuel filter water drain	Drain			
Electrolyte level and terminals of battery		Check	Check	Check
Tyre pressure		Check	Check	Check
Leaks in air-, oil- or fuel system		Check	Check	Check
Oil cooler			Clean	Clean
Radiator			Clean	Clean
Intercooler			Clean	Clean
Torque of wheel nuts		Check	Check	Check
Brake system (if installed)		Check/Adjust	Check/Adjust	Check/Adjust
Safety valve (10)				Test
Door hinges			Grease	Grease
Towing eye shaft or ball coupling and its shaft			Grease	Grease
Shut-down switches				Check
Pressure drop over separator element (2)			Measure	Replace
Fan V-belts (3)		Adjust	Adjust	Adjust
Fuel tank			Clean	Clean
Compressor oil (8)				Change
Compressor oil filter (6)		Replace		Replace
Coolant (3,5,9)			Analyse	Change
Air filter element (1)				Replace
Engine oil (3,4)			Change	Change
Engine oil filter (3)			Replace	Replace
Fuel prefilter (3,7)			Replace	Replace
Fuel filter (3,7)			Replace	Replace
Engine inlet and outlet valves (3,12)			Adjust	Adjust
Filter element from regulating valve				Replace
Flow restrictor in oil scavenge line				Clean
Inspection by Atlas Copco Service Technician				Inspection

Notes

	<ol style="list-style-type: none">1 More frequently when operating in a dusty environment.2 Replace the element when the pressure drop exceeds 0.8 bar (11.6 psi).3 Refer to the engine operation manual.4 200 hours is only valid when using Par Oil SAE 15W40.5 Check additive concentration every 200 h. Change coolant every 1000 h.6 Use Atlas Copco oil filters, with by-pass valve, as specified in the parts list.7 Replace the fuel filters regularly. Gummed or clogged filters mean fuel starvation and reduced engine performance. The quality of the fuel determines the frequency of renewal.8 PAROIL M9 The following part numbers can be ordered from Atlas Copco to check on inhibitors and freezing point:<ul style="list-style-type: none">• 2913 0028 00 refractometer• 2913 0029 00 pH meter10 See section 5.3 Safety valve11 See section 3.2 Before starting12 The engine inlet and outlet valves initially need to be adjusted at 500 hours. Rocker cover gasket: 2914 8239 00
	<p>Keep the bolts of the housing, the lifting beam, towbar and axles securely tightened. For torque values see section 8 Technical specifications.</p>

4.6 Oil specifications

	It is strongly recommended to use Atlas Copco branded lubrication oils for both compressor and engine.
---	--

High-quality, mineral, hydraulic or synthesized hydrocarbon oil with rust and oxidation inhibitors and anti-foam and anti-wear properties is recommended.

The viscosity grade should correspond to the ambient temperature and ISO 3448, as follows:

Type of lubricant	Compressor	Engine
between 30 Centigrade and 40 Centigrade	PAROIL S	PAROIL 15W40
between -5 Centigrade and 30 Centigrade	PAROIL M PAROIL S	PAROIL 15W40
between -20 Centigrade and -5 Centigrade	PAROIL S	PAROIL 5W30

	<p>Never mix synthetic with mineral oil.</p> <p>Remark: When changing from mineral to synthetic oil (or the other way around), you will need to do an extra rinse:</p> <p>After doing the complete change procedure to synthetic oil, run the unit for a few minutes to allow good and complete circulation of the synthetic oil. Then drain the synthetic oil again and fill again with new synthetic oil. To set correct oil levels, proceed as in normal instruction.</p>
---	--

4.6.1 Synthetic compressor oil PAROIL S

Liter (US gal, IMP gal, Cu.ft)	Order number
5 liter can (1.32 Us gal can, 1.1 Imp gal can, 0.18 cu.ft can)	1615 5950 00
20 liter can (5.28 Us gal can, 4.40 Imp gal can, 0.70 cu.ft can)	1615 5951 00
209 liter barrel (55.17 Us gal barrel, 45.98 Imp gal barrel, 7.31 cu.ft barrel)	1615 5952 00

4.6.2 Mineral compressor oil PAROIL M

Liter (US gal, IMP gal, Cu.ft)	Order number
5 liter can (1.32 Us gal can, 1.1 Imp gal can, 0.18 cu.ft can)	1615 5947 00
20 liter can (5.28 Us gal can, 4.4 Imp gal can, 0.7 cu.ft can)	1615 5948 00
209 liter barrel (55.18 Us gal barrel, 45.98 Imp gal barrel, 7.32 cu.ft barrel)	1615 5949 00

4.6.3 Synthetic engine oil PAROIL 5W30

Liter (US gal, IMP gal, Cu.ft)	Order number
5 liter can (1.32 Us gal can, 1.1 Imp gal can, 0.18 cu.ft can)	1604 6060 00
20 liter can (5.28 Us gal can, 4.4 Imp gal can, 0.7 cu.ft can)	1604 6059 00

4.6.4 Mineral engine oil PAROIL SAE 15W40

Liter (US gal, IMP gal, Cu.ft)	Order number
5 liter can (1.32 Us gal can, 1.1 Imp gal can, 0.18 cu.ft can)	1615 5953 00
20 liter can (5.28 Us gal can, 4.4 Imp gal can, 0.7 cu.ft can)	1615 5954 00
209 liter barrel (55.17 Us gal barrel, 45.98 Imp gal barrel, 7.31 cu.ft barrel)	1615 5955 00

4.7 Oil level check

4.7.1 Check engine oil level

Also consult the Engine Operation Manual for the oil specifications, viscosity recommendations and oil change intervals.

For intervals, see **4.5 Preventive maintenance schedule for the compressor**.

Check engine oil level according to the instructions in the Engine Operation Manual and if necessary top up with oil.

4.7.2 Check compressor oil level

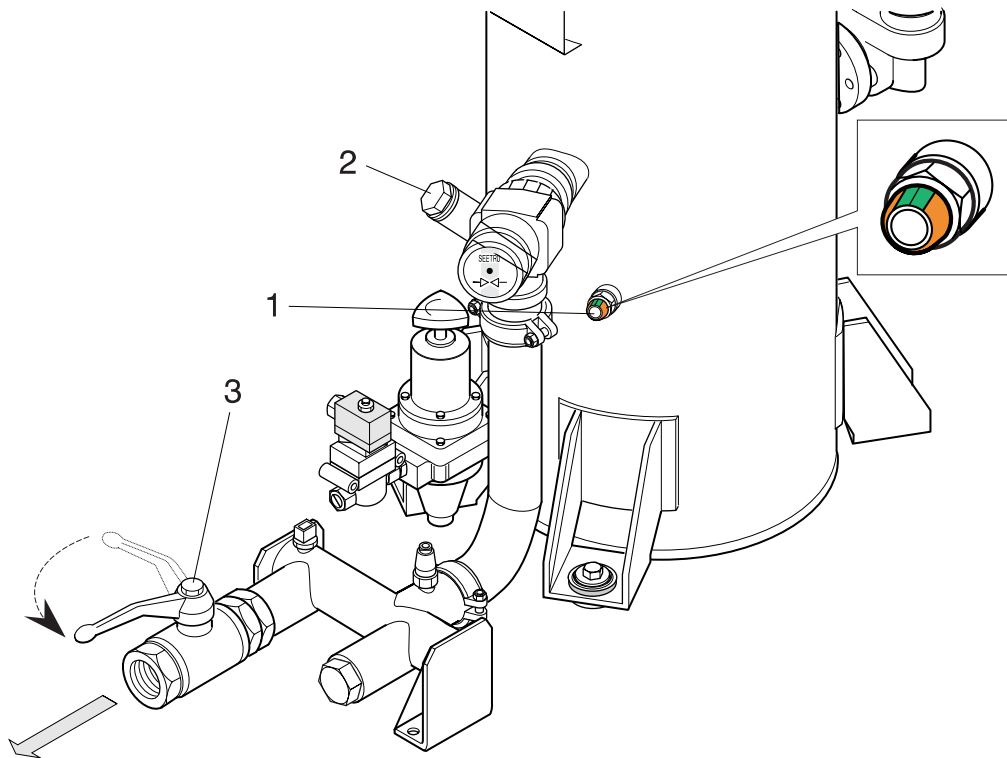

Check compressor oil level

With the compressor standing horizontal, check the level of the compressor oil.

The pointer of the oil level gauge (1) must register in the upper extremity of the green range. Add oil if necessary.



Before removing the oil filler plug (2), ensure that the pressure is released by opening an air outlet valve (3).

4.8 Oil and oil filter change

4.8.1 Engine oil and oil filter change

See section 4.5 Preventive maintenance schedule for the compressor.

4.8.2 Topping up the compressor oil

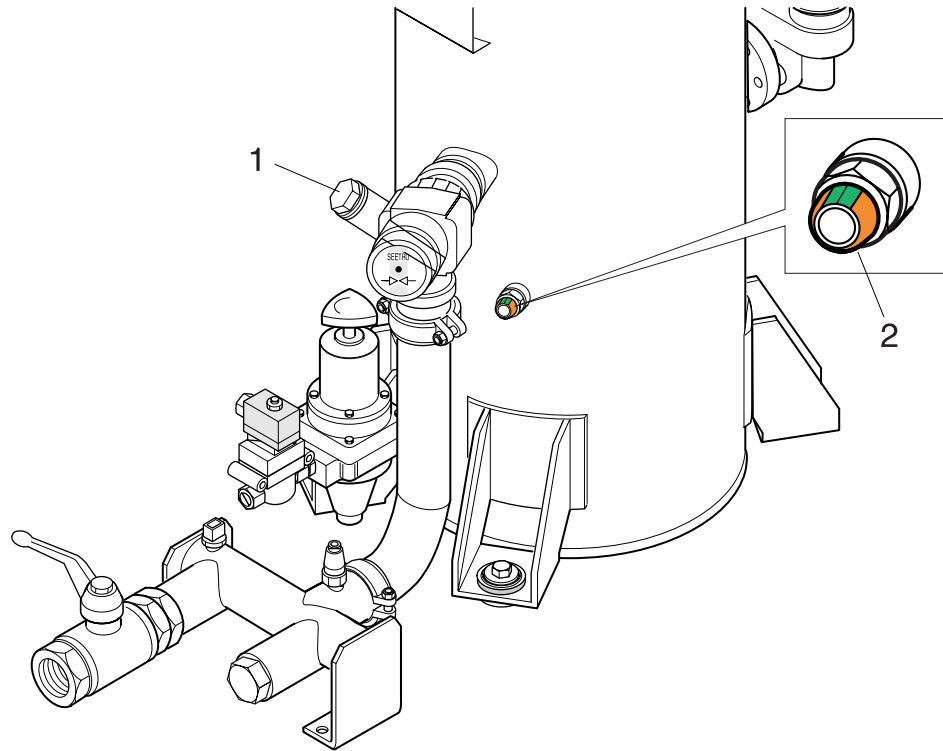

Topping up compressor oil

1	Stop the compressor. Wait a few minutes until the pressure is released through the automatic blow-down valve. Make sure that all pressure is released by loosening the filler plug (1) one turn.
2	Wait a few minutes until the oil level is constant.
3	Remove the filler plug (1) and top up with oil until the pointer of the oil level gauge (2) is in the upper part of the green area.
4	Reinstall and tighten the filler plug (1).

4.8.3 Compressor oil and oil filter change

The quality and the temperature of the oil determine the oil change interval.

The prescribed interval is based on normal operating conditions and an oil temperature of up to 100 Centigrade (212 Fahrenheit) (see section 4.5 Preventive maintenance schedule for the compressor).

When operating in high ambient temperatures, in very dusty or high humidity conditions, it is recommended to change the oil more frequently.

	<p>In this case, contact Atlas Copco</p>
---	--

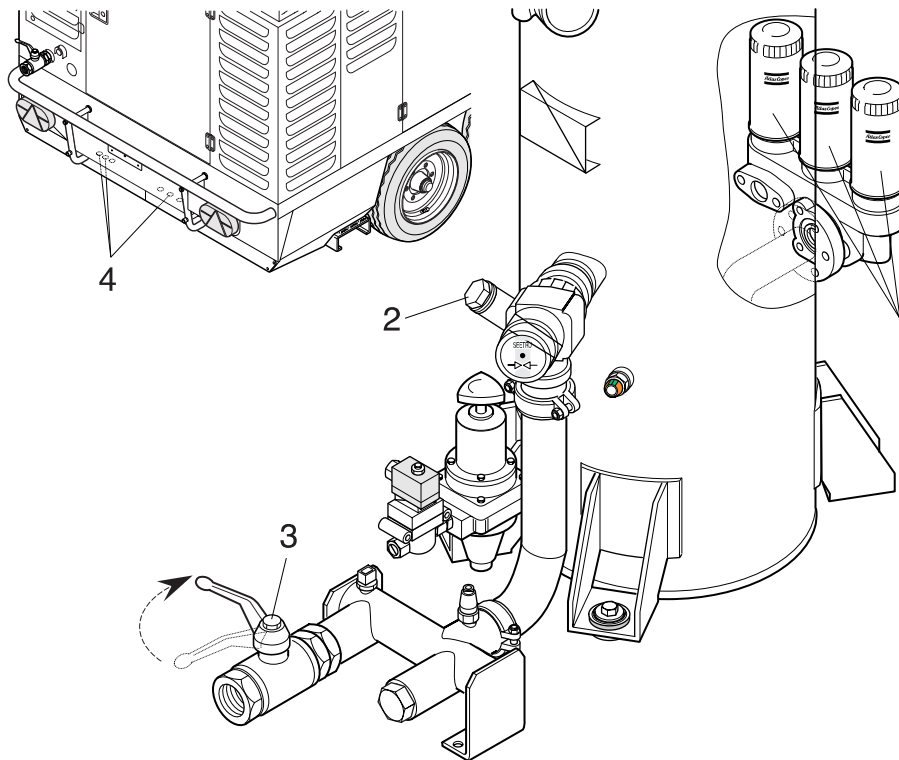

1	Run the compressor until warm. Close the outlet valve(s) (3) and stop the compressor. Wait until the pressure is released through the automatic blow-down valve. Unscrew the oil filler plug (2) one turn. This uncovers a vent hole, which permits any pressure in the system to escape.
2	Drain the compressor oil by removing all relevant drain plugs (4). Catch the oil in a drain pan. Screw out the filler plug (2) to speed up draining. After draining, place and tighten the drain plugs (4).
3	Remove the oil filters (1), e.g. by means of a special tool. Catch the oil in a drain pan.
4	Clean the filter seat on the manifold, taking care that no dirt drops into the system. Oil the gasket of the new filter element. Screw it into place until the gasket contacts its seat, then tighten one half turn only.
5	Fill the air receiver until the pointer of the oil level gauge is in the upper part of the green area. Be sure that no dirt gets into the system. Reinstall and tighten the filler plug.
6	Start the compressor and let it run unloaded for a few minutes.

7	Stop the compressor, wait a few minutes and top up with oil until the pointer of the oil level gauge is in the upper part of the green area.
---	--

	Never add more oil. Overfilling results in oil consumption.
---	---

4.9 Coolant specifications

The use of the correct coolant is important for good heat transfer and corrosion protection of liquid-cooled engines.

Liquid-cooled engines are factory filled with PARCOOL EG.

PARCOOL EG is an Extended Life Ethylene Glycol based coolant, offering improved heat transfer and complete corrosion protection to preserve wet liners, cylinder head, radiator etc..

Optimum premixed 50:50 dilution ratio offers antifreeze protection to -40 Centigrade (-40 Fahrenheit).

4.9.1 PARCOOL EG

Liter (US gal, IMP gal, Cu.ft)	Order number
5 liter can (1.32 Us gal can, 1.1 Imp gal can, 0.18 cu.ft can)	1604 5308 00
25 liter can (6.6 Us gal can, 5.5 Imp gal can, 0.88 cu.ft can)	1604 5307 00
210 liter barrel (55.44 Us gal barrel, 46.2 Imp gal barrel, 7.35 cu.ft barrel)	1604 5306 00

4.10 Coolant check



Never remove the cooling system filler cap while coolant is hot. The system may be under pressure. Remove the cap slowly and only when coolant is at ambient temperature. A sudden release of pressure from a heated cooling system can result in personal injury from the splash of hot coolant.

4.10.1 Monitoring coolant condition

In order to guarantee the lifetime and quality of the product, thus to optimise engine protection, regular coolant-condition-analysis is advisable.

The quality of the product can be determined by three parameters:

Visual check

- Verify the outlook of the coolant regarding colour and make sure that no loose particles are floating around.

pH measurement

- Check the pH value of the coolant using a pH-measuring device.
- The pH-meter can be ordered from Atlas Copco with part number 2913 0029 00.
- Typical value for EG = 8.6.
- If the pH-level is below 7 or above 9.5, the coolant should be replaced.

Glycol concentration measurement

- To optimise the unique engine protection features of the PARCOOL EG the concentration of the Glycol in the water should be always above 33 vol.%.
- Mixtures with more than 68 vol.% mix ratio in water are not recommended, as this will lead to high engine operating temperatures.
- A refractometer can be ordered from Atlas Copco with part number 2913 0028 00.



In case of a mix of different coolant products this type of measurement might provide incorrect values.

4.10.2 Topping up of coolant

- Verify if the engine cooling system is in a good condition (no leaks, clean,...).
- Check the condition of the coolant.
- If the condition of the coolant is outside the limits, the complete coolant should be replaced (see section **4.10.3 Replacing the coolant**).
- Always top-up with PARCOOL EG.
- Topping up the coolant with water only, changes the concentration of additives and is therefore not allowed.

4.10.3 Replacing the coolant

Drain

- Completely drain the entire cooling system.
- Used coolant must be disposed or recycled in accordance with laws and local regulations.

Flush

- Flush twice with clean water. Used coolant must be disposed or recycled in accordance with laws and local regulations.
- From the Atlas Copco Instruction book, determine the amount of PARCOOL EG required and pour into the radiator top tank.
- It should be clearly understood that the risk for contamination is reduced in case of proper cleaning.
- In case a certain content of 'other' coolant remains in the system, the coolant with the lowest properties influences the quality of the 'mixed' coolant.

Fill

- To assure proper operation and the release of trapped air, run the engine until normal engine operation temperature is reached. Turn off the engine and allow to cool.
- Recheck coolant level and add if necessary.

4.11 Cleaning coolers

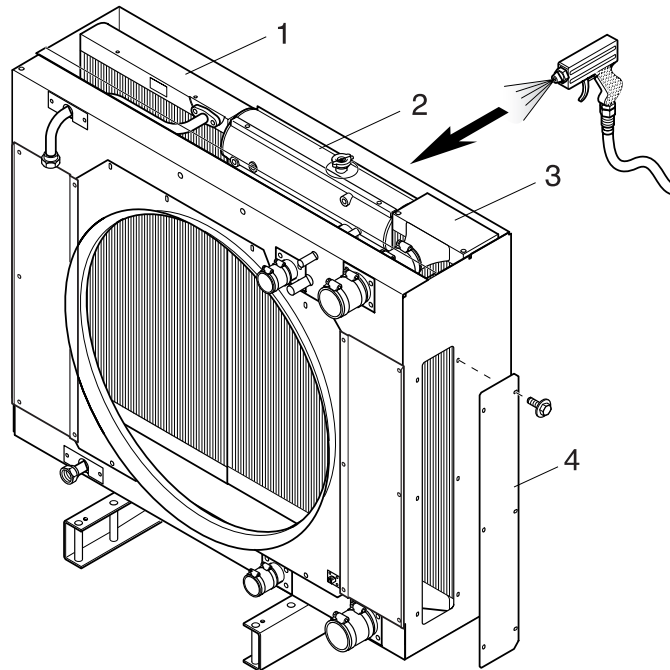

Compressor oil cooler (1), radiator (2) and intercooler (3)

Keep the coolers (1), (2) and (3) clean to maintain the cooling efficiency.

Service doors (4) are provided on both sides of the fan cowl to allow easy access to the fan side surface of the coolers.



Remove any dirt from the coolers with a fibre brush. Never use a wire brush or metal objects.

Clean by air jet in the direction of the arrow.

Steam cleaning in combination with a cleansing agent may be applied (do not use jet at max. power).



To avoid damaging the coolers, angle between jet and coolers should be approx. 90 °.

Close the service door(s).



Protect the electrical and controlling equipment, air filters, etc. against penetration of moisture.
Never leave spilled liquids such as fuel, oil, coolant and cleansing agents in or around the compressor.

4.12 Battery care



Before handling batteries, read the relevant safety precautions and act accordingly.

If the battery is still dry, it must be activated as described in section **4.12.2 Activating a dry-charged battery**.

The battery must be in operation within 2 months from being activated; if not, it needs to be recharged first.

4.12.1 Electrolyte

	Read the safety instructions carefully.
---	---

Electrolyte in batteries is a sulphuric acid solution in distilled water.

The solution must be made up before being introduced into the battery.

	Always pour the sulphuric acid carefully into the distilled water; never pour the water into the acid.
---	--

4.12.2 Activating a dry-charged battery

- Take out the battery.
- Battery and electrolyte must be at equal temperature above 10 Centigrade (50 Fahrenheit).
- Remove cover and/or plug from each cell.
- Fill each cell with electrolyte until the level reaches the mark on the battery. If there is no mark on the battery, the level must be above the plates for at least 10 mm (0.4 in) to 15 mm (0.6 in).
- Rock the battery a few times so that possible air bubbles can escape; wait 10 minutes and check the level in each cell once more; if required, add electrolyte.
- Refit plugs and/or cover.
- Place the battery in the compressor.

4.12.3 Recharging a battery

Before and after charging a battery, always check the electrolyte level in each cell; if required, top up with distilled water only. When charging batteries, each cell must be open, i.e. plugs and/or cover removed.



Use a commercial automatic battery charger according to its manufacturer's instructions.

Apply with preference the slow charging method and adjust the charge current according to the following rule of thumb:

Battery capacity in Ah divided by 20 gives safe charging current in Amp.

4.12.4 Battery maintenance

- Keep the battery clean and dry.
- Keep the electrolyte level above the plates or at the indicated level. Level above plates at least 10 mm (0.4 in) to 15 mm (0.6 in). Top up with distilled water only.
- Keep the terminals and clamps tight, clean, and lightly covered with petroleum jelly.

4.13 Compressor element overhaul

When a compressor element is due for overhaul, it needs to be done by Atlas Copco. This guarantees the use of genuine parts and correct tools with care and precision.

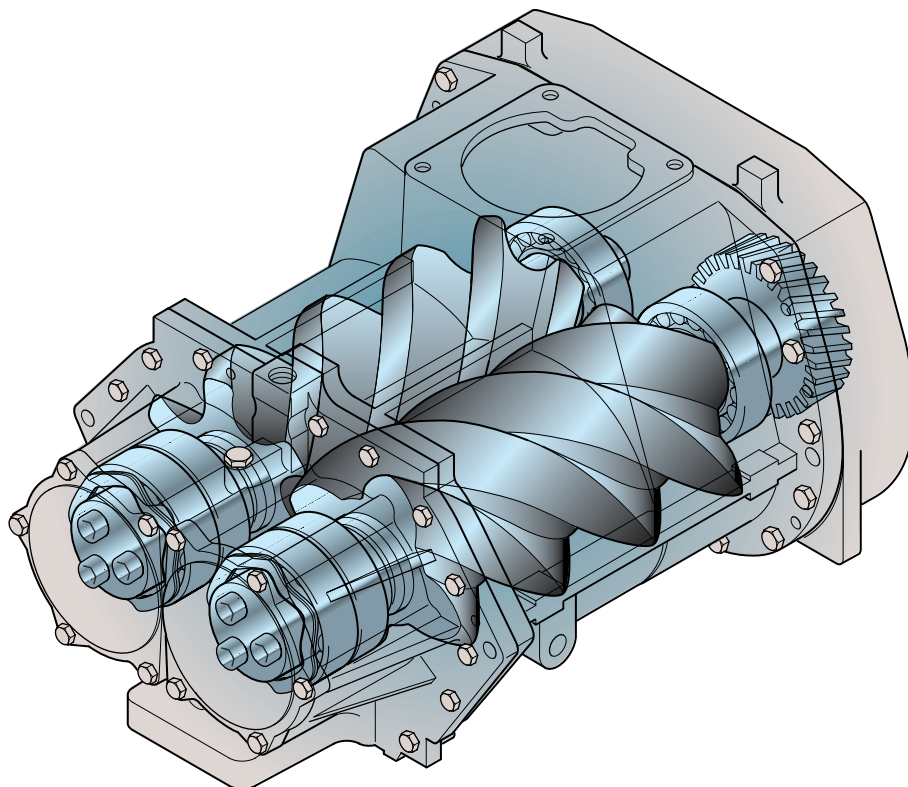

5 Adjustments and servicing procedures

5.1 Adjustment of the continuous regulating system

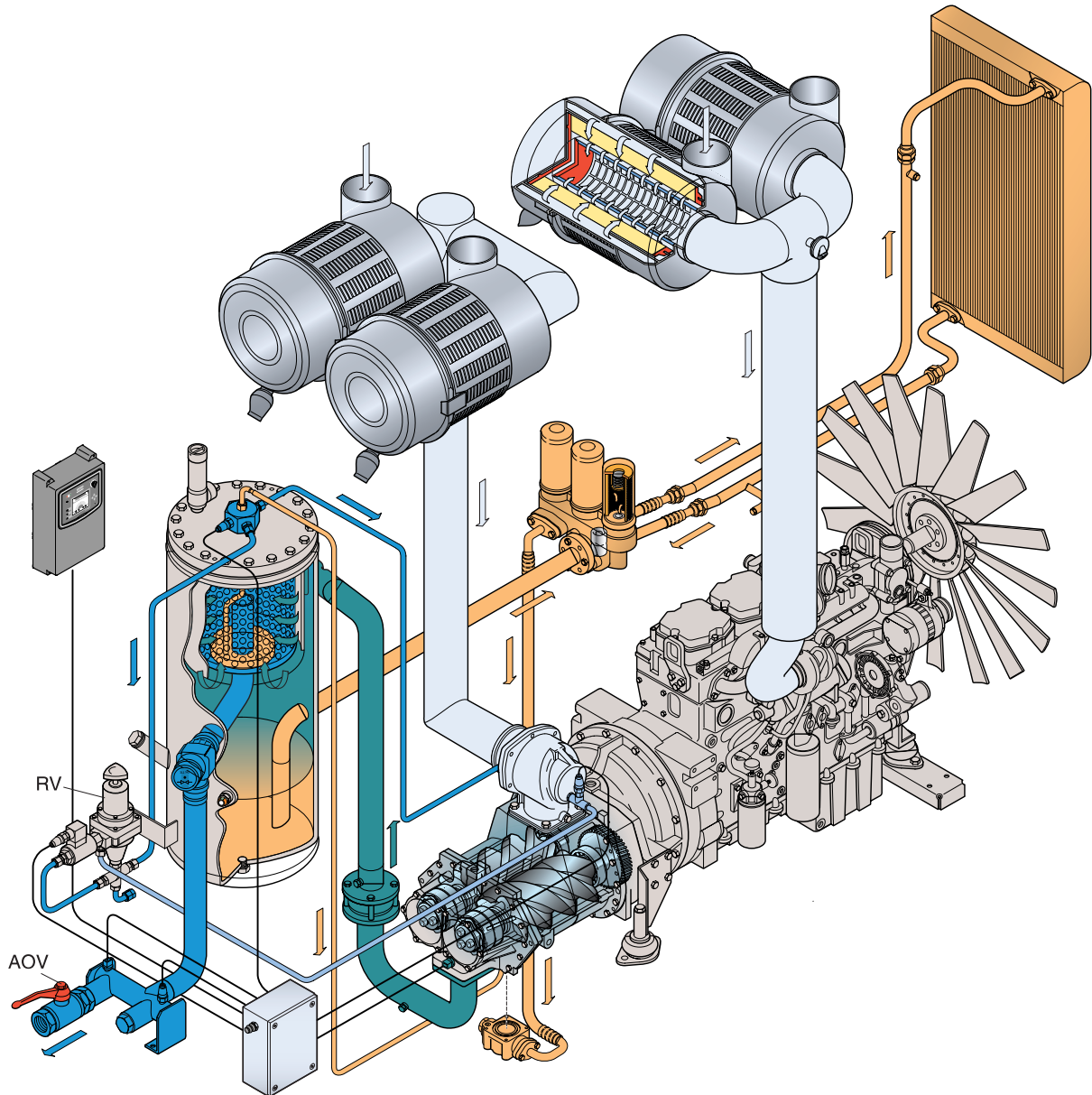

The working pressure is determined by the tension of the spring in the regulating valve (RV). This tension can be increased to raise the pressure and decreased to lower it by turning the adjusting wheel clockwise and anti-clockwise respectively.

To adjust the normal working pressure, proceed as follows:

- 1 Loosen the lock nut of the regulating valve.
- 2 Release Regulating Valve (turn out).
- 3 With the outlet valves (AOV) closed, adjust the regulating valve (RV), until a pressure is reached of nominal pressure + 1.4 bar (+ 20 psi).
- 4 Lock the regulating valve (RV) by fixing the lock nut.

5.2 Air filters engine / compressor

5.2.1 Main parts

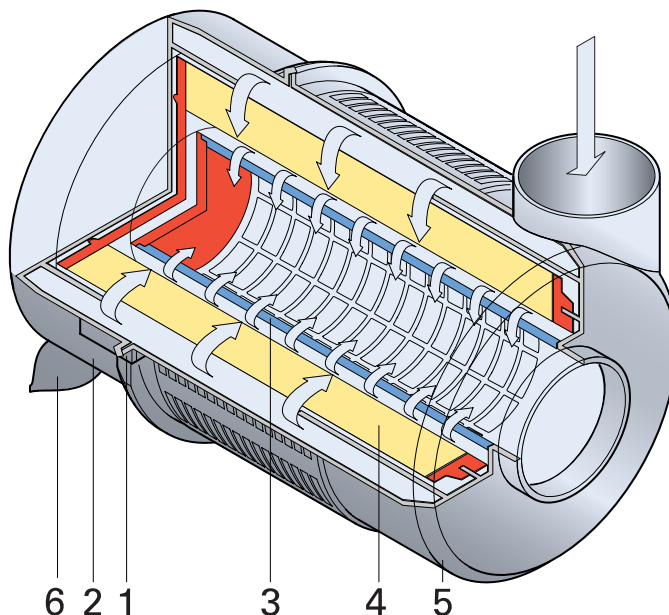

Air filter

Reference	Name
1	Snap clips (4x)
2	Dust trap cover
3	Safety cartridge
4	Filter element
5	Filter housing
6	Vacuator valve



The Atlas Copco air filters are specially designed for the application. The use of non-genuine air filters may lead to severe damage of the engine and/or compressor elements.

5.2.2 Cleaning the dust trap

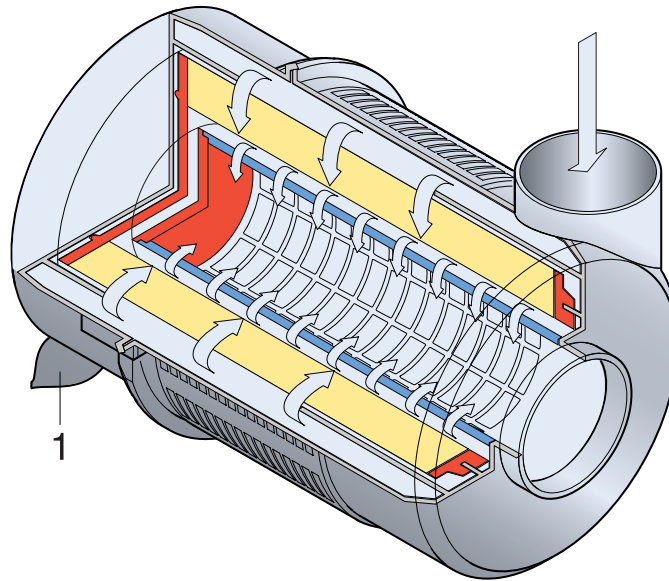

Air filter

To remove dust from the dust trap pinch the vacuumator valve (1) several times.

5.2.3 Replacing the filter element and the safety cartridge

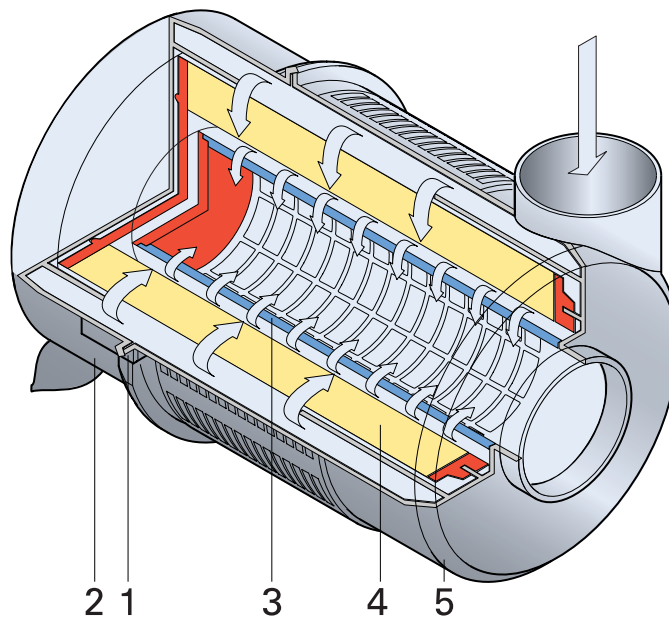



Air filter

The instructions apply to one air filter and should be repeated for both air filters engine and air filters compressor.

Step	Action
1	Release the snap clips (1) and remove the dust trap cover (2). Clean the inside of the cover.
2	Withdraw the filter element (4) and safety cartridge (3) from the housing (5).
	Discard the filter element when damaged.

Step	Action
	A dirty safety cartridge (3) is an indication of a malfunctioning filter element.

	Replace the filter element and the safety cartridge at the same time. New elements should be inspected for tears and punctures before installation.
---	---

	The safety cartridge cannot be cleaned.
---	---

3	Reassemble in reverse order of dismantling.
4	Inspect and tighten all air intake connections.

5.2.4 Air receiver

The air receiver is tested according to official standards. Regularly have inspections carried out in conformity with local regulations.

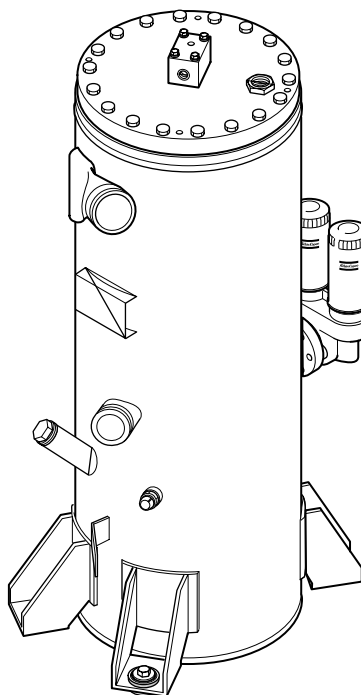

	Daily drain condensate.
---	-------------------------

5.3 Safety valve



All adjustments or repairs are to be done by an authorized representative of the valve supplier, see section **1.7 Specific safety precautions**.

Following checks must be carried out:

- A check of the opening of the lifting gear, twice a year.
This can be done by screwing the cap of the valve anti-clockwise.
- A check of the set pressure once a year according to the local regulations. This check cannot be done on the compressor and must be carried out on a proper test bench.

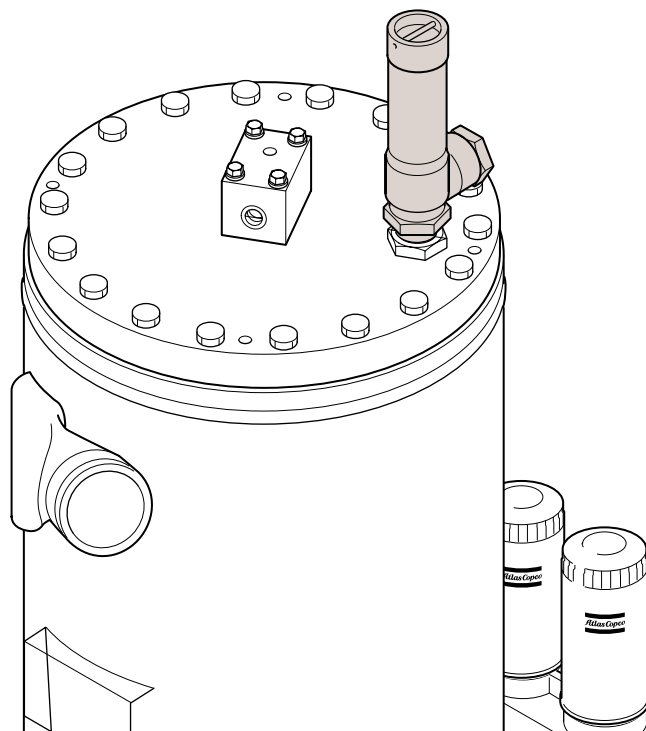

5.4 Fuel system

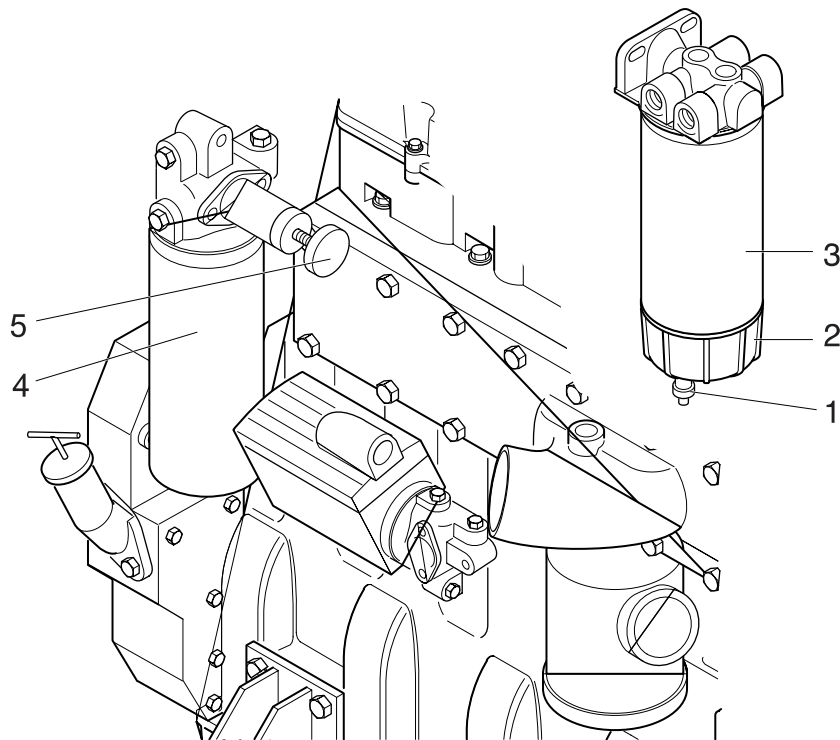

Fuel filter

Replacing the filter elements:

Installation instructions:

Step	Action
1	Drain fuel from the bowl.
2	Remove filter (2, 3), filterelement (4) and separate bowl (2) from element (3).
3	Apply film of gas oil to new bowl seat.
4	Screw bowl (2) to new element (3) tightly by hand.
5	Apply film of gas oil to new element seals.
6	Screw on filter (2, 3) and filterelement (4) tightly by hand.
7	Open head vent and operate pump (5). Close vent when fuel begins to purge.
8	Check for leaks, retighten if necessary.

Drain instructions:

Step	Action
1	Open bowl drain valve (1), operate pump (5) and pump water out.
2	Close drain valve (1).



Fuel leaked or spilled onto hot surfaces or electrical components can cause a fire. To help prevent possible injury, turn the "OFF/ON" switch in position "OFF" when changing fuel filters or water separator elements. Clean up fuel spills immediately.

Prime the fuel system in order to fill the fuel filter. Prime the fuel system in order to purge trapped air. The fuel system should be primed under the following conditions:

- Compressor is put in operation for the first time
- Running out of fuel
- Storage
- Replacement of the fuel filter



Do not loosen the fuel lines at the fuel manifold. The fittings may be damaged and/or a loss of priming pressure may occur when the fuel lines are loosened.

Open the fuel priming pump and operate the fuel priming pump (5) until a strong pressure is felt. This procedure will require considerable strokes. Lock the fuel priming pump (5).

5.5 Brake adjustments

5.5.1 Brake shoe adjustment (no ABS)

- Tighten the adjustment nut (A) on the wheel brake with a spanner until the wheel will not rotate in the direction of travel.
- Centre the brake shoes by applying the parking brake several times.
- Turn back the adjustment bolt (A) by approximately one turn, until no braking effect can be felt when the wheel is turned in a forward direction.
- Check the position of the brake equalizer compensators with the parking brake applied. Positioned at right angles to the brake rods = even play on both wheel brakes. Re-adjust brakes if necessary.

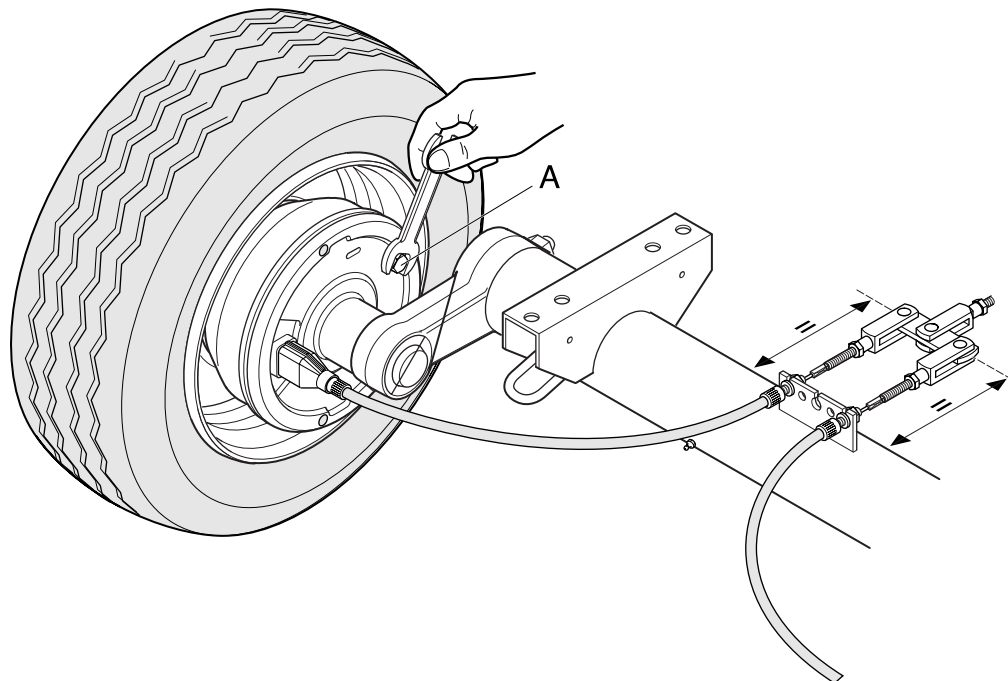

- As a check, apply the parking brake slightly and check that the braking effect on the wheels (in the direction of travel) is the same on the right and on the left.

5.5.2 Brake cable adjustment

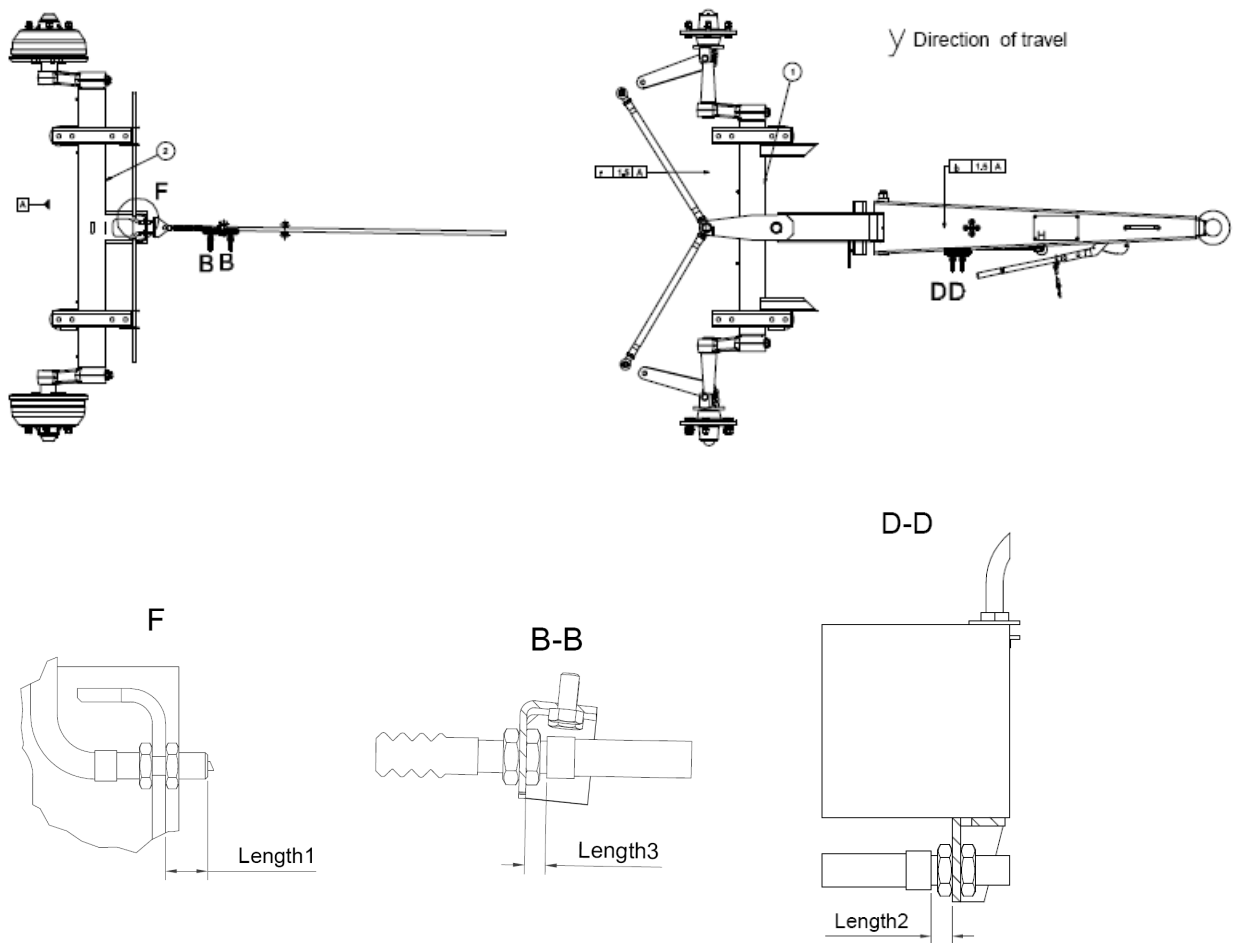

Brake cable adjustment

Rotate those nuts to adjust brake cable.

- . Rotate the nuts on position 'D' to adjust length2,
- . Rotate the nuts on position 'B' to adjust length3,
- . Rotate the nuts on position 'F' to adjust length1.

Use 200-300 N force to pull or push the brake handle several times , then position the handle on the-not-engaged-tooth position, adjust again if necessary.

Test brake

- . Operate brake to working level, check the lock part which need to locate half or threequarters of range tooth .

5.5.3 Use and maintenance of axle

1. For the nuts used in U bolts, the first check must carry out half month later, and then check them every two month.
2. Check the pressure of wheels every three month .
3. Grease axle every three month.
4. For front turning system, the frist adjustment must be finished three month later, and check it when check vehicle.
5. It's free maintenance for lef spring.



The value of torque to tight nuts which used in U bolt: 240 N.m



The maximum turning angle is 39 degree whether go head or back off. Otherwise towbar will be damaged even axle.

6 Problem solving

It is assumed that the engine is in good condition and that there is adequate fuel flow to the filter and injection equipment.

	An electrical fault must be traced by an electrician.
---	---

Make sure that the wires are not damaged and that they are clamped tight to their terminals.

For denomination of switches, relays, etc., see **2.5 Electric system**.

See also section **3.3.1 Control panel**.

Problem: Compressor capacity or pressure below normal.

Possible faults	Corrective actions
Air consumption exceeds capacity of compressor.	Check equipment connected.
Choked air filter elements (AF).	Remove and inspect elements. Clean or replace, if necessary.
Regulating valve (RV) defective.	Have regulating valve removed and inspected by an Atlas Copco Service representative.
Blow down valve stuck in open position.	Check and correct as necessary.
Loading valve (LV) leaking past O-ring.	With compressor running at max. load speed, disconnect hose leading to unloader. If air leaks from the hose, remove and inspect loading valve. Replace damaged or worn O-rings.
Oil separator element clogged.	Have element removed and inspected by an Atlas Copco Service representative.
Air intake throttle valve remains partially closed.	Remove air filters, air intake manifold and throttle valve spring seat. Withdraw the valve and inspect. Replace parts where necessary. Caution: the spring seat is fixed with 4 short and 2 long setscrews: first remove the short screws, then release the spring tension unscrewing the long ones.
Safety valve (SV) leaking.	Remove and inspect. Replace if not airtight after reinstallation.
Blow-off valve leaking.	Remove and inspect. Replace if necessary.

Problem: Pressure in air receiver rises above maximum and causes safety valve to blow.

Possible faults	Corrective actions
Regulating valve (RV) opens too late or its ball valve spring is broken.	Have regulating valve removed and inspected by an Atlas Copco Service representative.
Air leaks in regulating system.	Check hoses and their fittings. Stop leaks; replace leaking hoses.
Air intake throttle valve does not close for some reason.	Remove air filters, air intake manifold and throttle valve spring seat. Withdraw the valve and inspect. Replace parts where necessary. Caution: the spring seat is fixed with 4 short and 2 long setscrews: first remove the short screws, then release the spring tension unscrewing the long ones.
Minimum pressure valve malfunctioning.	Remove and inspect valve.
Blow-off valve malfunctioning.	Remove and inspect valve.

Problem: After working some time, the unit stops through a shutdown switch.

Possible faults	Corrective actions
Engine oil pressure too low.	Refer to the engine instruction manual.
Compressor or engine overheating.	See corrective actions “Compressor overheating”.
Fuel tank contains insufficient fuel.	Fill fuel tank.
Low coolant level.	Top up cooling system.

Problem: Air and oil mist expelles from air filters immediately after stopping.

Possible faults	Corrective actions
Check valve at element outlet.	Remove and inspect. Replace if necessary. Replace air filter elements and safety cartridges. Check the oil level and add oil if necessary. Run the compressor for a few minutes, stop and recheck oil level.
Plunger of oil stop valve jammed.	Remove and inspect. Replace if necessary. Replace air filter elements and safety cartridges. Check the oil level and add oil if necessary. Run the compressor for a few minutes, stop and recheck oil level.

Problem: Compressor overheating.

Possible faults	Corrective actions
Insufficient compressor cooling.	Locate compressor away from walls; when banked with other compressors, leave space between them.
Oil cooler clogged externally.	Clean oil cooler. Refer to section 4.11 Cleaning coolers .
Oil cooler clogged internally.	Consult Atlas Copco.
Oil filters clogged.	Replace oil filters.
Oil level too low.	Check oil level. Top up with recommended oil if necessary.
Thermostatic by-pass valve remains stuck in opened position.	Remove valve and check for proper opening and closing. Replace if out of order.
Fan blade(s) broken.	Check and correct if necessary.
Oil stop valve malfunctioning.	Remove and inspect valve.
Oil separator element (OS) clogged.	Have element removed and inspected by an Atlas Copco Service representative.

Alternator precautions

- 1 Never reverse the polarity of the battery or the alternator.
- 2 Never break any alternator or battery connections while the engine is running.
- 3 When recharging the battery, disconnect it from the alternator. Before using booster cables to start the engine, be sure of the polarity and connect the batteries correctly.
- 4 Never operate the engine without the main or voltage sensing cables connected in the circuit.

7 Available options

The compressor can be delivered with following options:

Pressure vessel approval	ASME CE
Undercarriage	
Undercarriage	Wagon undercarriage, Tandem undercarriage ABS brakes Skid mounted Without undercarriage
Towing eye	Not included Nato ITA SWE
Towbar levelling device	
Road signalisation	Obligatory for road approval
Wheel chocks	
Air treatment	
Quality air equipment	Not included Aftercooler + waterseparator Aftercooler + waterseparator + reheater Aftercooler + waterseparator + PD Aftercooler + waterseparator + PD + reheater Aftercooler + waterseparator + PD + QD Aftercooler + waterseparator + PD + QD + reheater
Control panel	
Language	English Dutch Swedish German French Italian Spanish Norwegian Danish Portuguese Greek Finnish
General options	
Special application equipment	Not included Spark arrestor and inlet shut down valve Spark arrestor Inlet shut down valve
Cold weather equipment	
Remote start	
Manifold	Not included Manifold Manifold and sensors
Additional manifold	

Additional literature set	
Special frame color	
Special canopy color	Not included One color Two colors
Packaging	Not included Wooden case

8 Technical specifications

8.1 Torque values

8.1.1 General torque values

Torque values

The following tables list the recommended torques applied for general applications at assembly of the compressor.

For hexagon screws and nuts with strength grade 8.8

Thread size	Torque value (Nm / lbf.ft)
M6	9 (6.64)
M8	23 (16.97)
M10	46 (34.69)
M12	80 (59.04)
M14	125 (92.25)
M16	205 (151.29)

For hexagon screws and nuts with strength grade 12.9

Thread size	Torque value (Nm / lbf.ft)
M6	15 (11.07)
M8	39 (28.78)
M10	78 (57.56)
M12	135 (99.63)
M14	210 (154.98)
M16	345 (254.61)

8.1.2 Critical torque values

Axles to frame:

Assemblies	Torque value (Nm / lbf.ft)
Wheel nuts	270 (199.26)
Bolts, front axle/frame	205 (151.29)
Bolts, rear axle/frame	205 (151.29)

Compressor to frame:

Assemblies	Torque value (Nm / lbf.ft)
Bolts, elements/gear casing	46 (33.95)
Bolts, elements/support	80 (59.04)
Bolts, support/buffer	205 (151.29)
Bolts, buffer/frame	80 (59.04)

Engine to frame:

Assemblies	Torque value (Nm / lbf.ft)
Bolts, engine/support	205 (151.29)
Bolts, support/buffer	46 (33.95)
Bolts, buffer/frame	23 (16.97)

Lifting beams to frame:

Assemblies	Torque value (Nm / lbf.ft)
Bolts, lifting beams/yoke (M12)	125 (92.25)
Bolts, lifting beams/yoke (M16)	205 (151.29)
Bolts, lifting beams/A-Frames	205 (151.29)
Bolts, A-Frames/frame	205 (151.29)

Hose clamps:

Assemblies	Torque value (Nm / lbf.ft)
Pebra hose clamps on all IC/radiator hoses	12 (8.85)

Note

	Secure the drain cock and tank cap of the fuel tank handtight.
---	--

8.2 Compressor / engine specifications

8.2.1 Reference conditions

Designation		XAMS 1150 C9	XATS 1050 C9	XAHS 950 C9	XAVS900 C9
Absolute inlet pressure	bar(e)	1	1	1	1
	psi	14.5	14.5	14.5	14.5
Relative air humidity	%	-	-	-	-
Air inlet temperature	°C	20	20	20	20
	°F	68	68	68	68
Nominal effective working pressure	bar(e)	8.6	10.3	12	14
	psi	125	150	175	200

The inlet conditions are specified at the air inlet grating outside the canopy.

8.2.2 Limitations

Designation		XAMS 1150 C9	XATS1050 C9	XAHS950 C9	XAV900 C9
Minimum effective receiver pressure	bar(e)	4	4	4	4
	psi	58	58	58	58
Maximum effective receiver pressure, compressor unloaded	bar(e)	10	11.7	13.4	15.4
	psi	145	170	194	223
Maximum ambient temperature at sea level	°C	50	50	50	50
	°F	122	122	122	122
Minimum starting temperature	°C	-10	-10	-10	-10
	°F	14	14	14	14
Minimum starting temperature, with coldstart equipment	°C	-25	-25	-25	-25
	°F	-13	-13	-13	-13
Altitude capability	m				

8.2.3 Performance data

At reference conditions, if applicable, and at normal shaft speed, unless otherwise stated.

Designation		XAMS 1150 C9	XATS 1050 C9	XAHS 950 C9	XAVS900 C9
Engine shaft speed, normal and maximum	r/min	1800	1800	1800	1800
Engine shaft speed, compressor unloaded	r/min	1300	1300	1300	1300
Free air delivery ¹⁾	l/s	520	482	443	406
	US gal/s	138	128	117	107
	Imp gal/s	114	106	97	90
	cu.ft/s	18.4	17	15.7	14.4
Fuel consumption					
- at 100% FAD	kg/h	45	45.2	44.8	45.1
	lb/h	100.7	101.1	100.3	101.0
- at 75% FAD	kg/h	35.1	35.5	35.3	35.7
	lb/h	78.7	79.4	79.1	79.8
- at 50% FAD	kg/h	30.3	30.7	30.7	31.1
	lb/h	67.9	68.8	68.8	69.7
- at 25% FAD	kg/h	27.7	28	28	28.2
	lb/h	62	62.7	62.7	63.1
- at unload	kg/h	24.1	24.1	23.5	23.2
	lb/h	53.9	53.9	52.6	51.8
Specific fuel consumption	g/m ³	24.02	26.10	28.14	30.90
	dram/cu.ft	39 10 ⁻⁶	42 10 ⁻⁶	45 10 ⁻⁶	49.5 10 ⁻⁶
Typical oil content of compressed air	mg/m ³	<3	<3	<3	<3
	dram/cu.ft	< 1.6 10 ⁻⁶	< 1.6 10 ⁻⁶	< 1.6 10 ⁻⁶	< 1.6 10 ⁻⁶
Engine oil consumption (maximum)	g/h	112.4	113	112.1	112.8
	oz/h	4	3.9	4	4
Compressed air temperature at outlet valve	°C	110	110	110	110
	°F	230	230	230	230
Noise level					
- Sound pressure level (LP), measured acc. to ISO 2151 under free field conditions at 7 m distance	dB(A)	72	72	72	72
- Sound power level (LW) complies with 2000/14/EC	dB(A)	100	100	100	100

¹⁾ Free air delivery is measured according to ISO 1217 ed.3 1996 annex D

Tolerance:	<ul style="list-style-type: none"> +/- 5% 25 l/s (6.6 US gal, 5.5 Imp gal, 0.88 cu.ft) <FAD< 250 l/s (66 US gal, 55 Imp gal, 8.75 cu.ft) +/- 4% 250 l/s (66 US gal, 55 Imp gal, 8.75 cu.ft) <FAD
The international standard ISO 1217 corresponds to following national standards:	<ul style="list-style-type: none"> British BSI 1571 part 1 German DIN 1945 Part 1 Swedish SS-ISO 1217 American ANSI PTC9

8.2.4 Design data

Compressor element

Designation	
Number of compression stages	1

Engine

Designation		XAMS1150CD7-XATS1050CD7 XAHS950CD7 - XAVS900CD7
Make		Caterpillar
Type		C9 ATAAC
Coolant		Liquid
Number of cylinders		6
Bore	mm	112
	in	4.41
Stroke	mm	149
	in	5.87
Swept volume	l	8.81
	cu.in	538
Output according to DIN 6271 at normal shaft speed	kW	224
	hp	300
- Load factor	%	85
Capacity of oil sump:		
- Initial fill	l	34
	US gal	9
	Imp gal	7.5
	cu.ft	1.2
- Refill (max.) ¹⁾	l	32
	US gal	8.5
	Imp gal	7
	cu.ft	1.13
Capacity of cooling system	l	54
	US gal	14.3
	Imp gal	11.9
	cu.ft	1.91

¹⁾ With filter change.

Compressor

Designation		XAMS 1150 CD7 XATS 1050 CD7	XAHS 950 CD7 XAVS 900 CD7
		Capacity of compressor oil system	l
	US gal	21.1	21.1
	Imp gal	17.6	17.6
	cu.ft	2.83	2.83
Net capacity of air receiver	l	164	164
	US gal	43.3	43.3
	Imp gal	36.1	36.1
	cu.ft	5.79	5.79
Capacity of fuel tanks	l	796	796
	US gal	212.3	212.3
	Imp gal	175.1	175.1
	cu.ft	27.9	27.9
Air volume at inlet grating (approx.) ¹⁾	m ³ /s	13.1	13.1
	cfm	2.7 10 ⁴	2.7 10 ⁴

¹⁾ Air required for engine and compressor element cooling, for combustion and for compression.

Compressor dimensions

Designation		all units
Length	mm	5640
	in	220
Width	mm	2100
	in	81.9
Height	mm	2460
	in	95.9
Weight (ready-to-operate)		See indication on dataplate

9 Dataplate

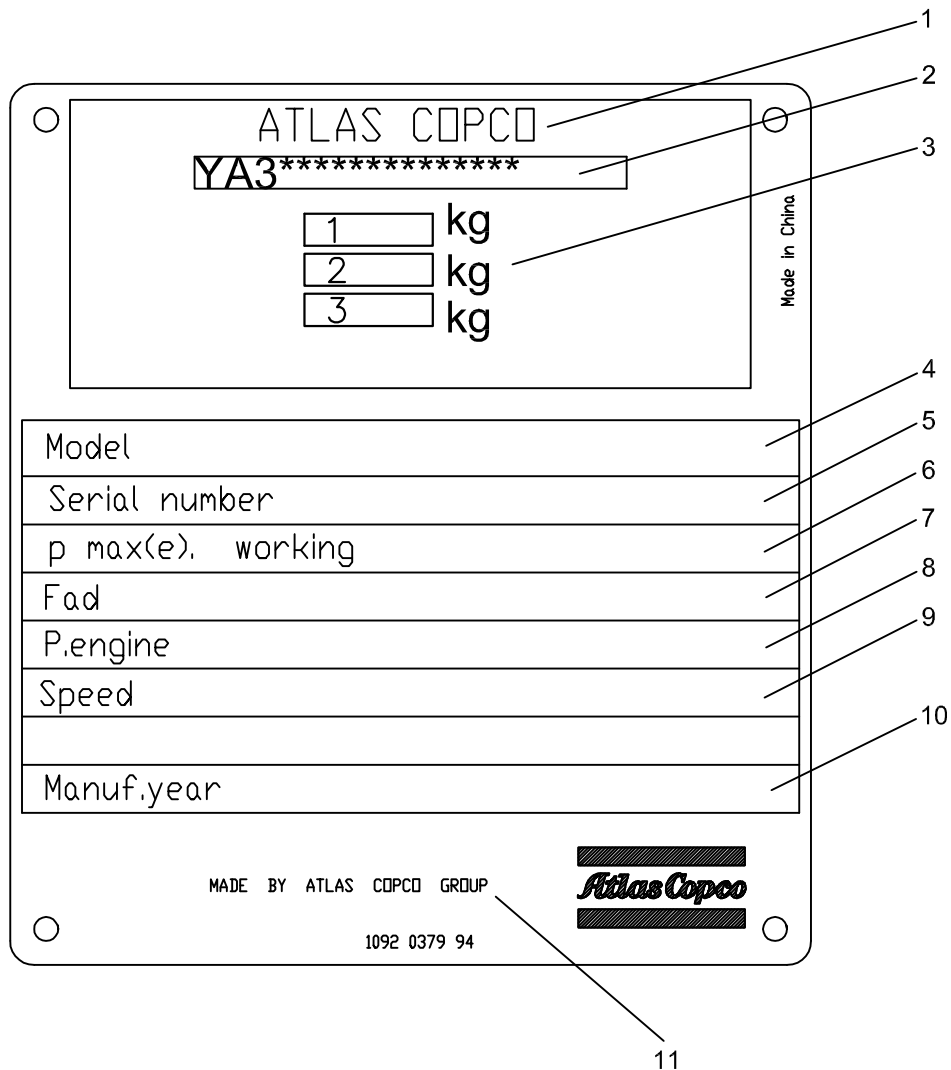

- 1 Company
- 2 Vehicle Identification number
- 3 Weight
- 4 Compressor Model
- 5 Compressor Serial number
- 6 Working Pressure
- 7 Free air delivery
- 8 Engine speed
- 9 Engine Power
- 10 Manufacture date
- 11 Manufacturer

10 Legislation

10.1 Parts, subjected to Pressure Equipment Directive 97/23/EC, cat. II and above

Safety valve: cat. IV

		XAMS 1150 CD C9	XATS 1050 CD7 C9	XAHS 950 CD7 C9	XAVS 900 CD7 C9
Set pressure	bar(e)	16	16	18	18
	psi	232	232	261	261
Design temperature	°C	130	130	130	130
	°F	266	266	266	266

10.2 Parts, subjected to Simple Pressure Vessel Directive 87/404/EC

Air Oil separator

		XAMS 1150 CD7 XATS 1050 CD7		XAHS 950 CD7 XAVS 900 CD7	
		Standard	Cold start equipment	Standard	Cold start equipment
Design pressure	bar(e)	18	18	18	18
	psi	261	261	261	261
Design temperature max.	°C	130	130	130	130
	°F	266	266	266	266
Design temperature min.	°C	-10	-25	-10	-25
	°F	14	-13	14	-13
Volume	l	164	164	164	164
	US gal	43.3	43.3	43.3	43.3
	Imp gal	36.1	36.1	36.1	36.1
	cu.ft	5.8	5.8	5.8	5.8

