

## Contents

|   |   |   |
|---|---|---|
| 1 | General Operations .....                        | 2 |
| 2 | Components .....                                | 3 |
| 3 | Specifications .....                            | 3 |
| 4 | Installation .....                              | 4 |
| 5 | Servicing & Maintenance .....                   | 6 |
| 6 | Operation -Activation .....                     | 6 |
| 7 | Installation of FirePro Generators .....        | 7 |
| 8 | Connection of Multiple FirePro Generators ..... | 8 |
| 9 | Safety Data Sheet (SDS) .....                   | 9 |

## 1 General Operations

The FirePro local application system is suitable for cabinet protection and other small risk areas. The system can be connected to a range of available power supplies OR a separate battery may be connected. The system will draw no current when not activating, so no draw on available power.

**This system can be configured for AUTOMATIC or MANUAL activation.**

1.1 The FP-08917 assembly is a non-monitored single detection zone. It designed to operate with FirePro Condensed aerosol generators.

1.2 Can be configured to operate:

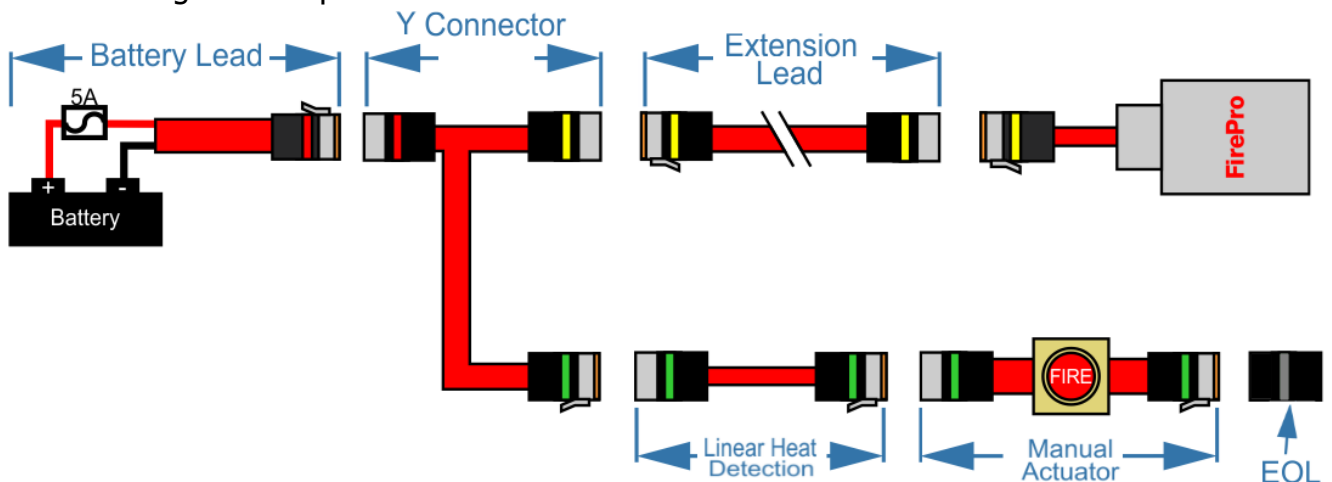

- Automatic** - using Linear Heat Detection Cable which will activate the system.
- Manual** – using a manual activation switch - FP-14053 switch.
- Combination** – which will allow automatic via the LHD or manual from the switch.

1.3 Power Supply – designed to operate on 6 to 30vDC supply. Number of FirePro units will depend on incoming power supply.

1.4 A thermal Fuse – FP-08825 may be connected to give a signal that system has operated.

1.5 When a fire is detected by the LHD cable (if Installed), the system will operate immediately. Pressing the manual switch (if installed) will also operate the system immediately.

### How Does it Work

All **FirePro** Fire Extinguishing Aerosol Generators use the latest generation FPC solid compound. Upon activation, the solid compound is transformed into a rapidly expanding, highly efficient gas, based on Potassium salts. It does not deplete oxygen levels. **Its built-in fail-safe activation system** ensures operation of the generators when required, even if everything else fails. The FirePro Aerosol Generators have a certified life of 15 years, with minimal maintenance required.

Ozone Depletion Potential (O.D.P.) = 0

Atmospheric Life Time (A.L.T.) = 0

Global Warming Potential (G.W.P.) = 0

Non-corrosive & Non-toxic

## 2 Components

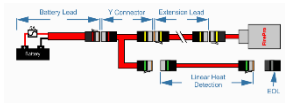

**FP-08917**  
Local Application system

- 1 x FP-08917
- 2x DP-3000
- 2x DP-2000
- 1 x Installation & Operators Manual
- Y Connector
- Deutsch Plug 3 Pin M/F, c/w heatshrink
- Deutsch Plug 2 Pin M/F, c/w heatshrink
- End-of-line Plug

### Agent Release Circuit



**FP-8919**  
Splitter Cable for installation of multiple FirePro generators.



**FP-08825**  
Thermal Fuse – used to provide signal that system has operated.

### FirePro Condensed Aerosol Generators



**FirePro Aerosol Generator**  
20g – 500g Unit.  
Constructed from S Steel. Complete with Deutsch Plug for easy install.



**FP-6200**  
Heavy Duty Bracket 316 SS.  
Suits FP-100, 200, 500 FirePro Aerosol Generators.



**FirePro Aerosol Generator**  
1200g – 5700g Unit.  
Constructed from S Steel. Complete with Deutsch Plug for easy install.



**FP-6100**  
Heavy Duty Bracket 316 SS.  
Suits FP-1200, 2000, 3000 5700 FirePro Aerosol Generators.

### Detection Circuit



**FP-9510**  
Linear Heat Detection Cable 182° C  
Supplied in Cut Lengths with Deutsch Plugs for easy install.  
Lengths: 1,2,4,6 & 8m



**FP-14053**  
Heavy Duty Switch including 316 SS Bracket.

### Installation Components



**FP-9500**  
2 Hour Fire Rated Shielded Cable.

### Service Components



**FP-8800**  
System Test Module – this unit simulates a FirePro generator.

### Signage



**FP-8960**  
Marine Signage for the System. A sheet of different size labels.



**FP-8962**  
Cabinet Signage for the System. A sheet of different size labels.

## 3 Specifications

|   |   |                         |                         |
|---|---|-------------------------|-------------------------|
| <b>Max Number of FirePro Units</b>          | <b>6v - 1 FP Unit</b>                     | <b>12v - 2 FP Units</b> | <b>24v - 4 FP Units</b> |
| <b>Activation Current for FirePro Units</b> | <b>Max 0.25A</b>                          | <b>Max 0.50A</b>        | <b>Max 1.00A</b>        |
| <b>Quiescent Current</b>                    | <b>0 A – No current drawn from supply</b> |                         |                         |
| <b>Power Supply</b>                         | <b>6-30vDC</b>                            |                         |                         |
| <b>Fuse for Power Supply</b>                | <b>5A</b>                                 |                         |                         |
| <b>Max Length of Linear Heat Detection</b>  | <b>50m</b>                                |                         |                         |
| <b>Max Number of FP-14053 Switches</b>      | <b>6 switches over 50m</b>                |                         |                         |

## 4 Installation

- 4.1 FirePro Aerosol Generators must be selected in accordance with approved FirePro design calculations and guidelines. FirePro Brackets must be installed using Bolts – Tec Screws will vibrate loose in vehicle/marine installations.
- 4.2 FirePro units have a self-activation temperature of 300°C. Location of units to be considered.
- 4.3 All cabling in the FirePro Installation **MUST** be Installed using min 0.75mm shielded Fire Rated Cable
- 4.4 Power **MUST** be connected directly power supply OR Battery to ensure operation of the system.

**6 – 30v DC. 5A fuse or circuit breaker to be installed on power supply.**

- 4.5 **Manual Actuator(s)** where installed, placement is to be considered – ensure that it is easily accessible in case of emergency. Follow instructions for the install of the FP-14053 switch.
- 4.6 **Linear Heat Detection** where installed, the system will activate automatically. Follow instructions as per FP-09510 product manual.
- 4.7 **System Test Point**

Due to regular testing requirements, it may be good to install a System Testing point. This is a break in the activation cable from the control panel. Attach Deutsch plugs which allow the FirePro Simulator to be connected. Locate where it is easy to access and be signed as “**FirePro System Test Point**”. **The benefit is that all FirePro units in the system will be disconnected for testing, so the chance of accidental activation during testing is reduced.** It creates a process which is easy to follow for anyone working on the system.

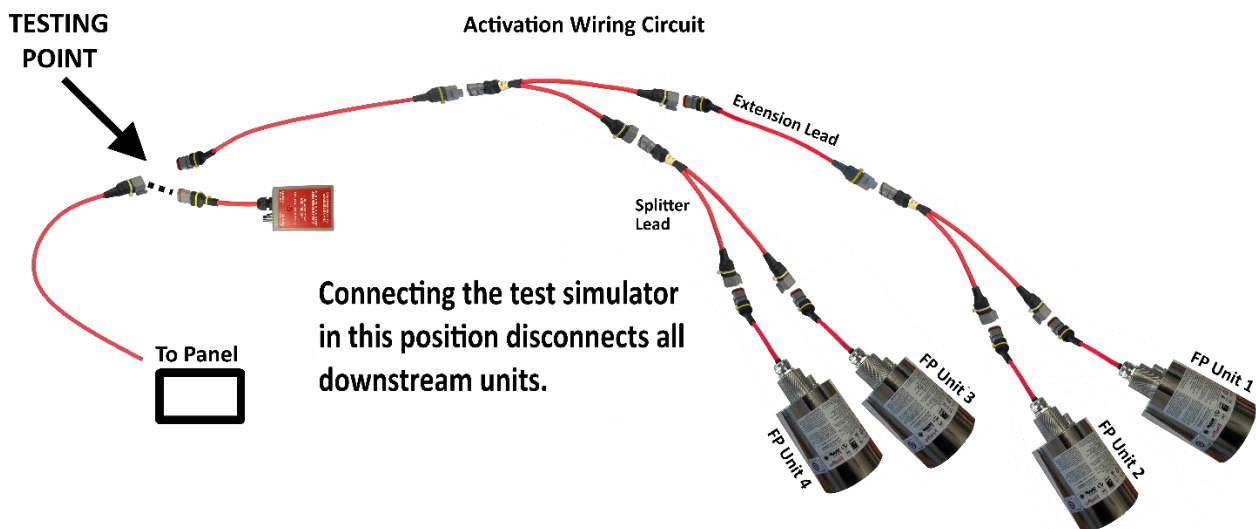

4.8 **Cable Requirements** - All cabling in the FirePro Installation MUST be done using 0.75mm shielded Fire Rated Cable. Care taken to ensure that all cables are isolated, and that RF shielding on cable is stripped back to ensure that there is not accidental grounding. Cables are colour coded for easy identification.

4.9 **Extension Leads** - Deutsch Plugs must be used to ensure water-proof connections are made throughout the installation.

| Colour |        | Circuit                   |
|--------|--------|---------------------------|
|        | Red    | Power                     |
|        | Yellow | Activation                |
|        | Green  | Detection / Manual Switch |

Deutsch Plug 2 Pin  
Male/Female



Deutsch Plug 3 Pin  
Male/Female

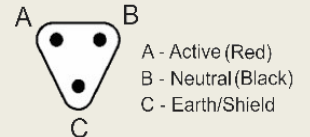

## 5 Servicing & Maintenance

The FirePro Suppression system should be serviced at least every 6 months in accordance with AS 1851, more often in aggressive environments. Periodic visual inspections of the installed system must also be conducted by the operators to ensure all installed parts are free from debris, rust, or electrical faults. Six Monthly servicing **must only be undertaken by accredited service technicians.**

**NO PERSONNEL SHOULD BE IN THE RISK AREA DURING TESTING  
UNTIL THE FIREPRO UNITS ARE DISCONNECTED AND TEST MODULES IN PLACE**

### Servicing and Maintenance Procedure

- 5.1 Disconnect the FirePro activation circuit (Yellow) at the panel, and connect the FirePro simulator.
- 5.2 Visually inspect all installed FirePro Generators, cable, connections, detection devices and siren/strobes. Look for any signs of damage or wear and replace as necessary.
- 5.3 Activate the system – after ensuring the FirePro Simulator is connected.  
**Note:** the FirePro Simulator will stay illuminated until the reset button on the simulator is pressed.
- 5.4 Reconnect the FirePro activation circuit.



### System Logbook

A logbook must be kept, recording all the relevant events concerning the installation. The logbook contains the items required that give a picture and provide for the recording of various things during the life of the installation. In the logbook you will find the following:

#### Content of logbook:

- General details
- Devices used
- Schematic diagrams
- Photos of the Original FirePro Installation
- Inspection reports

## 6 Operation -Activation

### Should the system be activated :

- 6.1 Keep the FirePro suppression gas within the risk until the fire is extinguished and not re-ignite.
- 6.2 In case of emergency, ensure all occupants have left the risk area and where possible alert emergency services.
- 6.3 DO NOT open any doors/hatches to the risk area for at least 20 minutes, to prevent re-ignition.
- 6.4 After 20 minutes, the Aerosol will fall to the ground as dust. Check risk area that is safe and commence clean-up with warm, soapy water.
- 6.5 The FirePro Aerosol generators are single use items, so will need to be replaced.

## 7 Installation of FirePro Generators

### 7.1 FirePro Condensed Aerosol Fire Extinguishing System Arrangement.

- 7.1.1 FirePro units and system components installed to allow inspection and maintenance.
- 7.1.2 Locate FirePro units where they are not exposed to mechanical damage, exposed to chemicals, or weather conditions, that may render them inoperative. Protective provisions shall be adopted, if necessary.
- 7.1.3 Firepro units shall be securely installed. Use heavy duty brackets where necessary. Brackets should be capable of handling the risk environment, including vibration.

### 7.2 Firepro units must be installed at **NOT less than the minimum safe** distances as specified in the design calcuations.

### 7.3 Means for prompt rescue of any trapped personnel shall be provided, including:

- 7.3.1 Adequate aisle ways/routes of exit.
- 7.3.2 Alarms – audible and visual, that operate immediately on detection of the fire.
- 7.3.3 Signs in accordance with relevent standards for the installation.

### 7.4 System components shall be positioned to the minimum clearances from energized electrical parts as per:AS 4487 and AS 3000.

### 7.5 Handling and Storage - when handling theCondensed Aerosol Generators do not:

- Disassemble the unit
- Carry out any welding work in the vicinity of the fire extinguishing system components.
- Exert force or impact which creates physical or mechanical damage to the casing.

#### STORAGE and OPERATIONAL CONDITIONS

- Temperature: -54 and +54°C
- Humidity: maximum 98% RH
- Service life: 15 years (date of manufacture appears on each generator)

### 7.6 Positioning



**CORRECT**

FP Units directing the aerosol stream away from opening



**INCORRECT**

FP units are directing the stream towards the opening.

## 8 Connection of Multiple FirePro Generators

Where multiple FirePro Generators are installed, they must be connected using the FP-08919 Splitter Lead. The Splitter Lead enables the activation current to pass to all FirePro generators and for monitoring of the circuit.



Splitter Leads can be installed at any point on the activation circuit and do not need to be installed adjacent to the fire control panel. For ease of install, servicing and more efficient field wiring, Splitter Leads should be installed in areas easy to access and minimise extension leads.

### Installation

8.1 FirePro generators **must** remain disconnected until system is completed. The FirePro Universal Test Module (P/N FP-08800) can be used to take the panel out of a fault condition.

8.2 The supply voltage of any system will determine the wiring which can be used

**6vDC Max = 1 FP Units      12vDC Max = 2 FP Units      24vDC Max = 4 FP Units**

8.3 Where additional units are required in the system a discharge delay module may be required. Need to check the system manual for specifications.

8.4 Connection of units

#### Connection of 2 FirePro Units

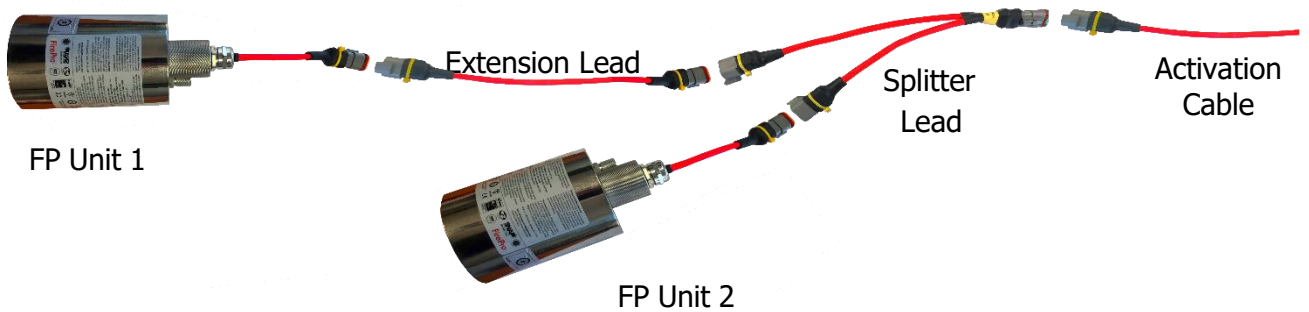

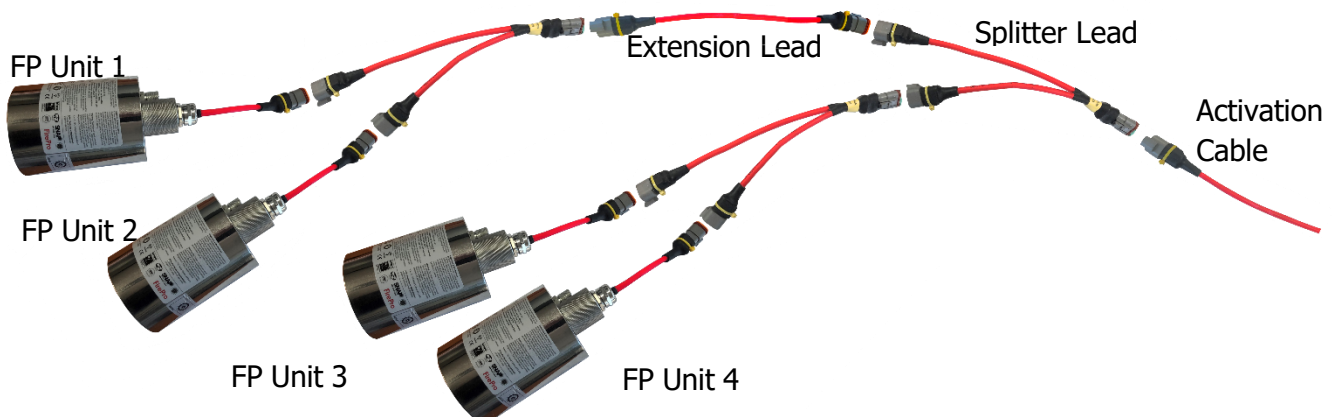

#### Connection of 4 FirePro Units





## 9 Safety Data Sheet (SDS)

This is an EXTRACT ONLY from the full SDS. The SDS is prepared by Chemwatch - to view the full SDS go to [www.chemwatch.com.au](http://www.chemwatch.com.au).

|   |  |              |  |  |  |  |          |  |  |  |  |              |  |  |  |  |            |  |  |  |  |         |  |  |  |  |
|---|--|--------------|--|--|--|--|----------|--|--|--|--|--------------|--|--|--|--|------------|--|--|--|--|---------|--|--|--|--|
|  | <p><b>HAZARDOUS SUBSTANCE. DANGEROUS GOODS.</b><br/><b>According to NOHSC Criteria, and ADG Code.</b></p>  |              |  |  |  |  |          |  |  |  |  |              |  |  |  |  |            |  |  |  |  |         |  |  |  |  |
| <p><b>PRODUCT NAME</b> CELANOVA FIREPRO</p>                                       | <p><b>CHEMWATCH HAZARD RATINGS</b></p> <table border="1"> <tr> <td>Flammability</td> <td style="background-color: #0000FF; width: 100px;"></td> <td style="background-color: #FFFF00; width: 100px;"></td> <td style="width: 100px;"></td> <td style="width: 100px;"></td> </tr> <tr> <td>Toxicity</td> <td style="background-color: #0000FF; width: 100px;"></td> <td style="background-color: #FFFF00; width: 100px;"></td> <td style="width: 100px;"></td> <td style="width: 100px;"></td> </tr> <tr> <td>Body Contact</td> <td style="background-color: #0000FF; width: 100px;"></td> <td style="background-color: #FFFF00; width: 100px;"></td> <td style="width: 100px;"></td> <td style="width: 100px;"></td> </tr> <tr> <td>Reactivity</td> <td style="background-color: #0000FF; width: 100px;"></td> <td style="background-color: #FFFF00; width: 100px;"></td> <td style="width: 100px;"></td> <td style="width: 100px;"></td> </tr> <tr> <td>Chronic</td> <td style="background-color: #0000FF; width: 100px;"></td> <td style="background-color: #FFFF00; width: 100px;"></td> <td style="width: 100px;"></td> <td style="width: 100px;"></td> </tr> </table> <p>SCALE: Min/Nil=0 Low=1 Moderate=2 High=3 Extreme=4</p> | Flammability |  |  |  |  | Toxicity |  |  |  |  | Body Contact |  |  |  |  | Reactivity |  |  |  |  | Chronic |  |  |  |  |
| Flammability  |  |              |  |  |  |  |          |  |  |  |  |              |  |  |  |  |            |  |  |  |  |         |  |  |  |  |
| Toxicity  |  |              |  |  |  |  |          |  |  |  |  |              |  |  |  |  |            |  |  |  |  |         |  |  |  |  |
| Body Contact  |  |              |  |  |  |  |          |  |  |  |  |              |  |  |  |  |            |  |  |  |  |         |  |  |  |  |
| Reactivity  |  |              |  |  |  |  |          |  |  |  |  |              |  |  |  |  |            |  |  |  |  |         |  |  |  |  |
| Chronic   |  |              |  |  |  |  |          |  |  |  |  |              |  |  |  |  |            |  |  |  |  |         |  |  |  |  |
| <p><b>PRODUCT USE</b> Fire extinguishing agent.</p>                               |     |              |  |  |  |  |          |  |  |  |  |              |  |  |  |  |            |  |  |  |  |         |  |  |  |  |

### POISONS SCHEDULE - None

| RISK  | SAFETY  |
|---|---|
| <ul style="list-style-type: none"> <li>• Contact with combustible material may cause fire.</li> <li>• Harmful if swallowed</li> <li>• Irritating to eyes and skin.</li> <li>• May cause SENSITISATION by skin contact.</li> <li>• Harmful to aquatic organisms may cause long-adverse effects in the aquatic environment.</li> <li>• Cumulative effects may result following exposure</li> <li>• May produce discomfort of the respiratory. system*</li> <li>• Possible respiratory sensitiser*.</li> <li>• May possibly affect fertility* (limited evidence).</li> </ul> | <ul style="list-style-type: none"> <li>• Keep away from combustible material</li> <li>• Avoid exposure - obtain special instructions before use.</li> <li>• To clean the floor and all objects contaminated by this material use water and detergent.</li> <li>• Keep away from food drink and animal feeding stuffs.</li> <li>• In case of contact with eyes rinse with plenty term of water and contact Doctor or Poisons Information Centre.</li> <li>• If swallowed IMMEDIATELY contact Doctor or. Poisons Information Centre (show this container or label).</li> <li>• This material and its container must be disposed of as hazardous waste.</li> </ul> |

### FIRST AID MEASURES

|                  |   |
|------------------|---|
| <b>SWALLOWED</b> | <ul style="list-style-type: none"> <li>• If swallowed do NOT induce vomiting.</li> <li>• If vomiting occurs, lean patient forward or place on left side (head-down position, if possible) to maintain open airway and prevent aspiration. Observe the patient carefully.</li> <li>• Never give liquid to a person showing signs of being sleepy or with reduced awareness.</li> <li>• Give water to rinse out mouth, then provide liquid slowly and as much as casualty can comfortably drink.</li> <li>• Seek medical advice.</li> </ul> |
| <b>EYE</b>       | <ul style="list-style-type: none"> <li>• If this product comes in contact with the eyes:</li> <li>• Wash out immediately with fresh running water.</li> <li>• Ensure complete irrigation of the eye.</li> <li>• Seek medical attention without delay; if pain persists or recurs seek medical attention.</li> <li>• Removal of contact lenses after an eye injury should only be undertaken by skilled personnel.</li> </ul>  |
| <b>SKIN</b>      | <ul style="list-style-type: none"> <li>• If skin contact occurs:</li> <li>• Immediately remove all contaminated clothing, including footwear.</li> <li>• Flush skin and hair with running water (and soap if available).</li> <li>• Seek medical attention in event of irritation.</li> </ul>   |
| <b>INHALED</b>   | <ul style="list-style-type: none"> <li>• If dust is inhaled, remove from contaminated area.</li> <li>• Encourage patient to blow nose to ensure clear passage of breathing.</li> <li>• If irritation or discomfort persists, seek medical attention.</li> </ul>   |