

The FirePro local application system is suitable for cabinet protection and other small risk areas. The system can be connected to a range of available power supplies OR a separate battery may be connected. The system will draw no current when not activating, so no draw on available power.

This system can be configured for AUTOMATIC or MANUAL activation.

- The FP-08917 assembly is a non-monitored single detection zone, designed to operate with FirePro Condensed aerosol generators.
- Power Supply – designed to operate on 6 to 30vDC supply. Number of FirePro units will depend on incoming power supply.
- A thermal Fuse may be connected to give a signal that system has operated.
- When a fire is detected by the LHD cable (if installed), the system will operate immediately. Pressing the manual switch (if installed) will also operate the system immediately.

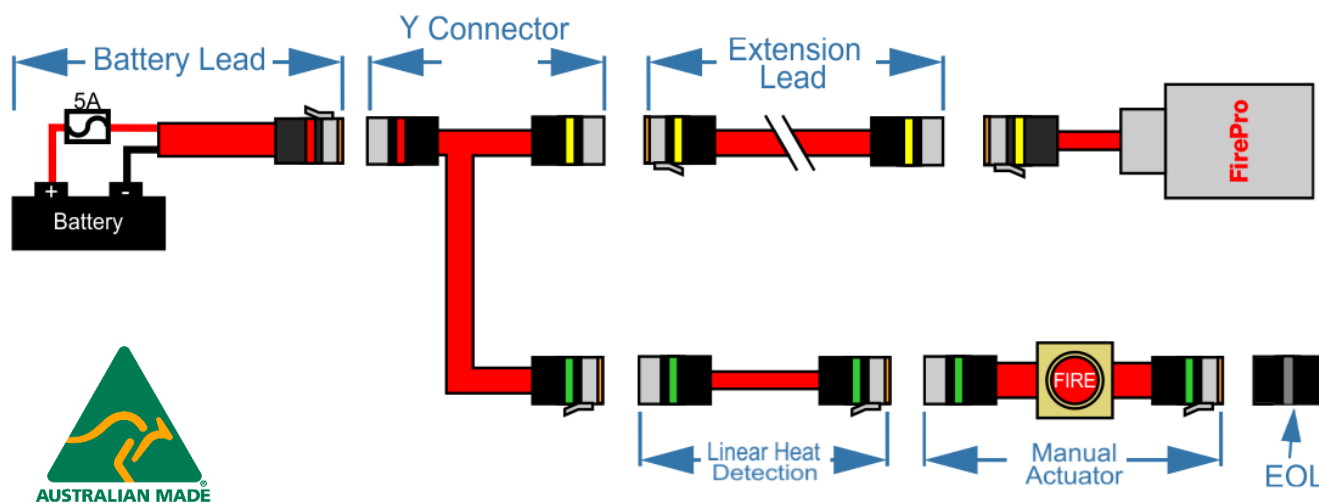

How Does it Work

All **FirePro** Fire Extinguishing Aerosol Generators use the latest generation FPC solid compound. Upon activation, the solid compound is transformed into a rapidly expanding, highly efficient gas, based on Potassium salts. It does not deplete oxygen levels. **Its built-in fail-safe activation system** ensures operation of the generators when required, even if everything else fails. The FirePro Aerosol Generators have a certified life of 15 years, with minimal maintenance required.

Ozone Depletion Potential (O.D.P.) = 0	Atmospheric Life Time (A.L.T.) = 0
Global Warming Potential (G.W.P.) = 0	Non-corrosive & Non-toxic