

Model FP-08872



Model FP-08873

Contents

1	Introduction	2
2	Components List.....	2
3	Design Considerations.....	3
4	Installation	4
5	Commissioning	5
6	Servicing and Maintenance	5
7	Specifications - Version I – Manual Voltage Selection	6
8	Specifications - Version II – Auto Voltage Selection.....	7

1 Introduction

The FP-08872 or FP-08873 Power Control Module provides a plug-in, supplementary power supply to be installed in conjunction with the FP-08450 or FP-08451 Fire Control Panel. The Power Control Module provides continuous power to the FirePro fire control panel, for a period of 24 hours (as per AS5062), in the event the main power supply fails.

There are 2 versions

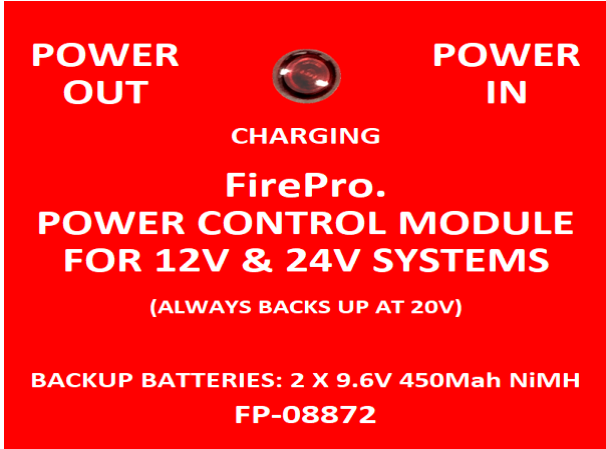
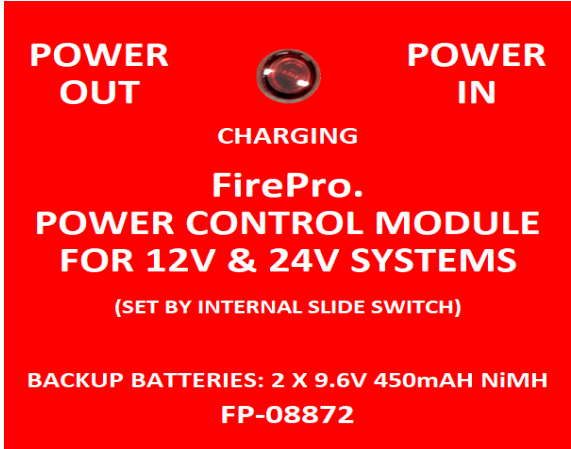
 <p>Version II This unit automatically selects incoming voltage</p>	 <p>Version I Incoming Voltage to be selected by Internal Switch</p>
--	--

There are slight differences in the operation of the module, details are provided in the manual. Batteries are the same for each module.

AS5062 Vehicle and Mobile Plant Installations required Battery backup unless there are two separate power supplies capable of operating the fire system for 24 hours.

2 Components List



FP-08872 Power Control Module
Power Control Module, 12 - 1x DP-2200
24vDC, NiMh, two side entry

Deutsch Plug
Pin Male/Female
c/w heatshrink



FP-08873 Power Control Module
Power Control Module, 12 - 1x DP-2200
24vDC, NiMh, one side entry

Deutsch Plug
2 Pin Male/Female,
c/w heatshrink



FP-18157 Replacement Backup Battery
9.6vDC, 450mAh NiMH

3 Design Considerations

3.1 Power Supply Input

The FirePro Power Control Module is a multi-voltage backup power supply, able to be configured to operate on either 12-volt DC or 24-volt DC. The configuration of the Power Control Module should be based on the available power supply, as the main power supply input **MUST** have the same voltage as the selected operating voltage of the Power Control Module.

The main power supply should be connected directly to the vehicle battery – NOT through the vehicle’s fuse block. This will ensure continuous power to the FIP. The connection to the vehicle battery must be done using a FP-14016 Battery lead, with an inline fuse installed.

3.2 System Limitations

Due to the capacity of the backup batteries, the FP-08872/73 Power Control Module has limitations on the number and type of components that can be connected while still providing 24hr backup. Each installed system will be designed around these limitations, and your supplier must be consulted prior to adding any additional devices or modules to the system.

The maximum number of FirePro generators able to be discharged is limited by the voltage of the main power supply. That is:

Voltage 12vDC Max = 2 Units	Voltage 24vDC Max = 4 Units
-----------------------------	-----------------------------

3.3 Mounting

For correct installation, the Power Control Module must be mounted by bolts or screws through the mounting holes in the flange on both sides of the Module. **No penetrations are to be made through the casing of the panel.**

The Power Control Module enclosure is rated IP65, so should be installed in a convenient location, away from where it may be affected by large amounts of water. The module does not need to be installed adjacent to the fire control panel.

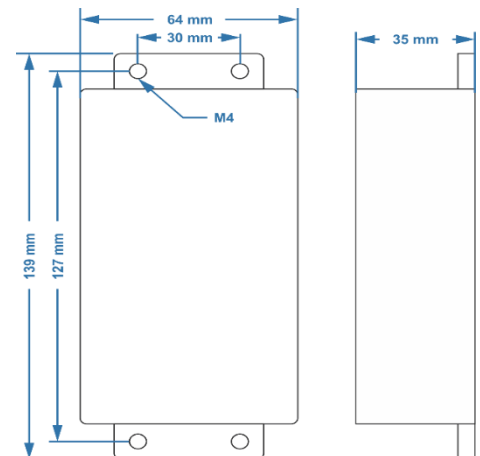

3.4 Cabling Requirements

When constructing extension leads the supplied Deutsch Plugs must be used to good connections are made throughout the installation. Use Heat Shrink to seal the back of the plug.

Deutsch Plug 2 Pin Male/Female

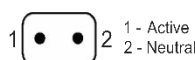

Deutsch Plug 3 Pin Male/Female

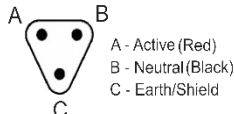

Color	Circuit
Red	Power Supply
Yellow	Activation
Green 1	Detection 1
Green 2	Detection 2
Blue	Discharge Advice
Orange	Siren/Strobe
White	Relay Output

3.5 Operation

The Power Control Module operates when both a Main Power supply and the internal backup battery are connected. Should the main supply fail or drop below operating voltage, the module automatically switches the power supply to the internal batteries. When the Power Control Module has been connected the "Charging" LED will flash continuously to indicate that the main power supply is providing good supply.

4 Installation

1. The output cable to the FIP should remain disconnected until all other steps are completed.
2. **When supplied, the internal batteries are disconnected.** Before connecting the main power supply, open the Power Control Module and connect both internal batteries to the power terminals.
3. If **Version I module** Check the voltage of the available main supply, and using the internal switch select the appropriate operating voltage for the module. Version II is auto sensing so this step not required.
4. With the main supply voltage selected, it is now safe to connect the main power supply.
5. Using the FP-14016 Battery Lead, connect the Power Control Module directly to the vehicle battery and plug the Battery Lead into the "Power In" Input. If the main power supply voltage is correct, the "Charging" LED indicator will illuminate and flash.
6. If the LED indicator is illuminated and flashing, the Power Control Module can be closed and the FIP power cable can be connected to the "Power Out" output, marked red.

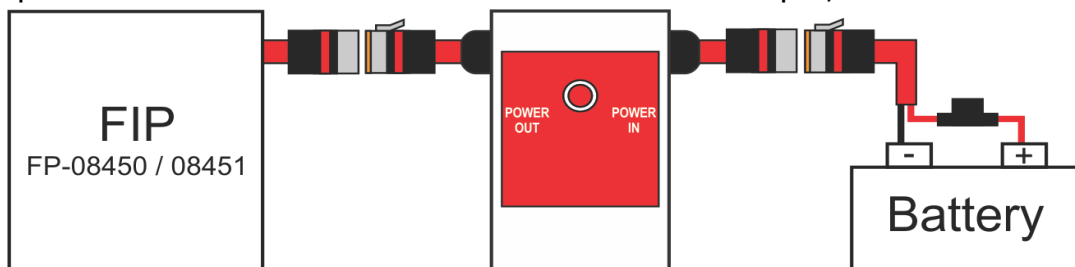
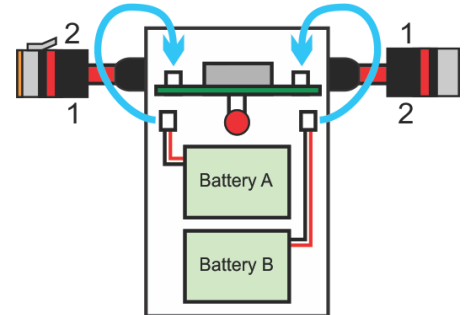

Note: Any connections must observe polarisation as shown in wiring diagram. Incorrect connections will not provide power and may damage the module or FIP.

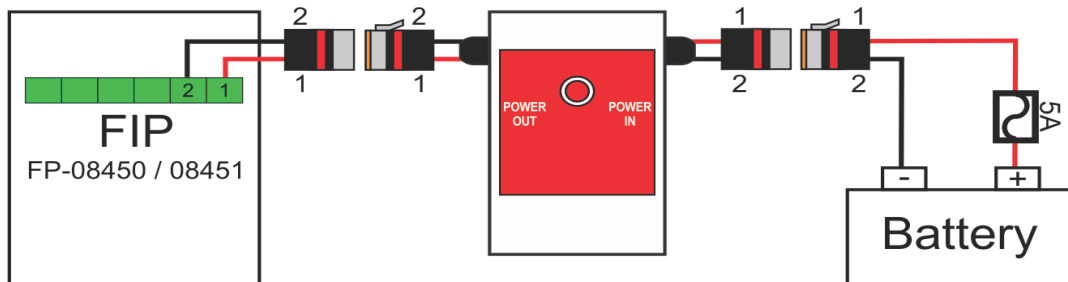

5 Commissioning

Commissioning should be performed when main supply and internal batteries are connected, and fire control panel is not in an alarm/fault condition.

1. Isolate and disconnect the any installed FirePro aerosol generators. This should generate a fault on the fire control panel.
2. Connect a FirePro FP-08800 Test Module.
3. Disconnect main power supply and ensure "Charging" LED indicator turns off.
4. Power supply will automatically switch to the internal batteries.
5. Ensure fire control panel remains operational and out of fault condition.
6. Reconnect main power supply.

6 Servicing and Maintenance

Inspection and servicing of the installed fire system should occur in accordance with the relevant Australian Standards. This should include a visual inspection of the enclosure to ensure the seals are intact.

Monitoring and operation of any installed modules should be tested as outlined in 6. Commissioning.

6.1 Replacing the Internal Batteries

The internal batteries **must** be changed every 3 years or if the backup batteries show signs of wear or damage. Both internal batteries must be replaced at the same time. New and old batteries **must not** be installed together. Old batteries should be disposed of in accordance with local regulations.

To replace the internal batteries:

1. Isolate and disconnect any installed FirePro aerosol generators. This should generate a fault on the fire control panel.
2. Connect a FirePro FP-08800 Test Module.
3. Disconnect main power supply and ensure "Charging" LED indicator turns off.
4. Isolate the Power Control Module by disconnecting both the output to the control panel and the input for the main power supply.
5. Remove the screws on the front to open the Power Control Module.
6. Disconnect and replace both internal batteries with 2x P/N FP-18156 Replacement Backup Battery.
7. Reconnect main supply input and control panel output.
8. If installed correctly, the "Charging" LED will indicate on the Power Control Module and the Control Panel will not be in a fault condition.
9. Disconnect the FirePro FP-08800 Test Module and reconnect all installed FirePro aerosol generators.

7 Specifications - Version I – Manual Voltage Selection

The Power Control Module can operate on either 12-volt DC or 24-volt DC main supply. A slide switch is located internally for the voltage selection.

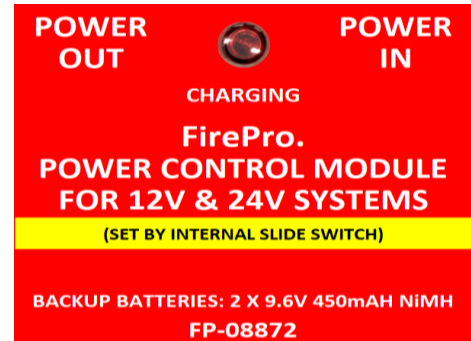

Selecting Operating Voltage

The Power Control Module MUST be configured to operate on either 12-volt DC or 24-volt DC main supply. Switch is

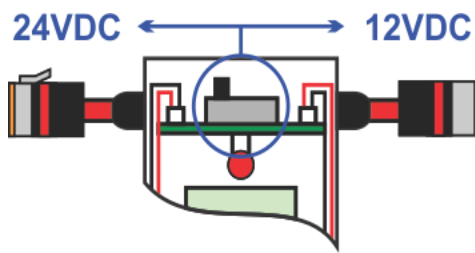

selected on the inside of the module. The incoming voltage must be the same as the incoming battery voltage.

Note: Incorrect voltage selection may cause the internal batteries to not fully charge and may cause damage to the module.

Specifications		
Enclosure material	Die Cast Aluminium	
Dimensions - mm	139L x 64W x 35D	
Ingress Protection	IP65	
Operating Temp.	-20 to 85°C	
Internal Battery	2 x 9.6v NiMH battery 450mAh	
Outgoing Fuse	1.5A Polyswitch self-resetting	
Incoming Fuse	1.5A Polyswitch self-resetting	
Voltage Selector	12vDC	24vDC
Backup Supply Voltage	10vDC	20vDC
Charging Voltage	13vDC	24vDC
Backup Supply takes over when incoming supply drops below	10vDC	20vDC
LED Charging Indicator	Incoming Power Over 13vDC	Incoming Power Over 24vDC
Output Current	max 1.5A	max 1.5A
Troubleshooting		
Problem	Possible Cause	Solution
"Charging" LED not illuminating	Incoming power below charging voltage. Connection to incoming power. Inline fuse has blown Internal battery disconnected	Check connection and polarity of battery lead and any extension cables. Check condition of the inline fuse and replace if necessary. Check connection to internal battery.

For additional assistance, contact your supplier.

8 Specifications - Version II – Auto Voltage Selection

The Power Control Module can operate on either 12-volt DC or 24-volt DC main supply. The module will auto sense the incoming supply and does not need any further adjustment.

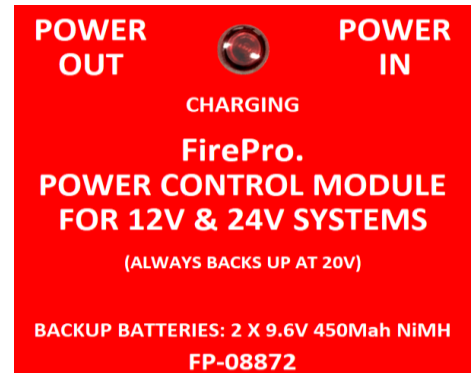

Specifications		
Enclosure material	Die Cast Aluminium	
Dimensions - mm	139L x 64W x 35D	
Ingress Protection	IP65	
Operating Temp.	-20 to 85°C	
Internal Battery	2 x 9.6v NiMH battery 450mAh	
Outgoing Fuse	1.5A Polyswitch self-resetting	
Incoming Fuse	1.5A Polyswitch self-resetting	
Auto Voltage Selector	12vDC	24vDC
Sensing Threshold V	Less than 15vDC	More than 15vDC
Backup Supply Voltage	20vDC	20vDC
Charging Voltage	13vDC	25vDC
Backup Supply takes over when incoming supply drops below	12vDC	25vDC
LED Charging Indicator	Incoming Power Over 13vDC	Incoming Power Over 25vDC
Output Current	max 1.5A	max 1.5A
Troubleshooting		
Problem	Possible Cause	Solution
"Charging" LED not illuminating	Incoming power below charging voltage. Connection to incoming power. Inline fuse has blown Internal battery disconnected	Check connection and polarity of battery lead and any extension cables. Check condition of the inline fuse and replace if necessary. Check connection to internal battery.

For additional assistance, contact your supplier.