



Contents

2	Introduction.....	2
3	Components List	2
4	Design Considerations	2
5	Installation	6
6	Wiring Diagram.....	7
7	Programming.....	7
8	Commissioning.....	9
9	Servicing and Maintenance.....	9
10	Operation	9
11	Troubleshooting.....	10
12	Specifications.....	10



1 Introduction

1.1 General Information

The FP-08850 Discharge Delay Module provides the FP-08450 or FP-08451 Fire Control Panel to activate additional FirePro generators, or delay the activation sequence of the fire system via programmable delay. The Discharge circuits are monitored.

1.2 Discharging Additional FirePro Generators

The number of FirePro generators a FP-08450 or FP-0451 Fire Control Panel can discharge depends on the voltage from the available power supply.

- 12vDC Max 2 x FirePro Generators
- 24vDC Max 4 x Firepro Generators

Where risk requires a more FirePro Units to be used, or a delay in the activation. The Discharge Delay module must be used. The module will activate FirePro generators sequentially in multiples of the quantities as per the available power supply.

1.3 Delaying Discharge

The discharge delay function includes a programmable timer that can be used to delay the activation of the FirePro generators until suitable. This can be set to account for vehicle or site specific conditions, for example; large areas of leakage, time allowance for evacuation, or increased hold time in the risk area.

2 Components List



FP-08850
Discharge Delay Module

2x DP-3000

Deutsch Plug 3 Pin M/F,
c/w heatshrink

3 Design Considerations

3.1 Normal Output

The "Normal" output (marked yellow 1) activates any connected FirePro generators immediately when the activation sequence begins - it is NOT affected by the delay timer.

Where a system requires the use of only the delayed discharge circuit, the supplied 3k3Ω End-of-line resistor must be installed on the "Normal" output, or a fault will be displayed.

3.2 Discharge Delayed Output

The "Discharge Delay" output (marked yellow 2) activates any connected FirePro generators as per the programming to the delay timer. The delay timer initiates when the control panel begins the activation sequence. When the programmed time is reached, the connected FirePro generators will discharge.

3.3 How to install a Discharge Delay Module

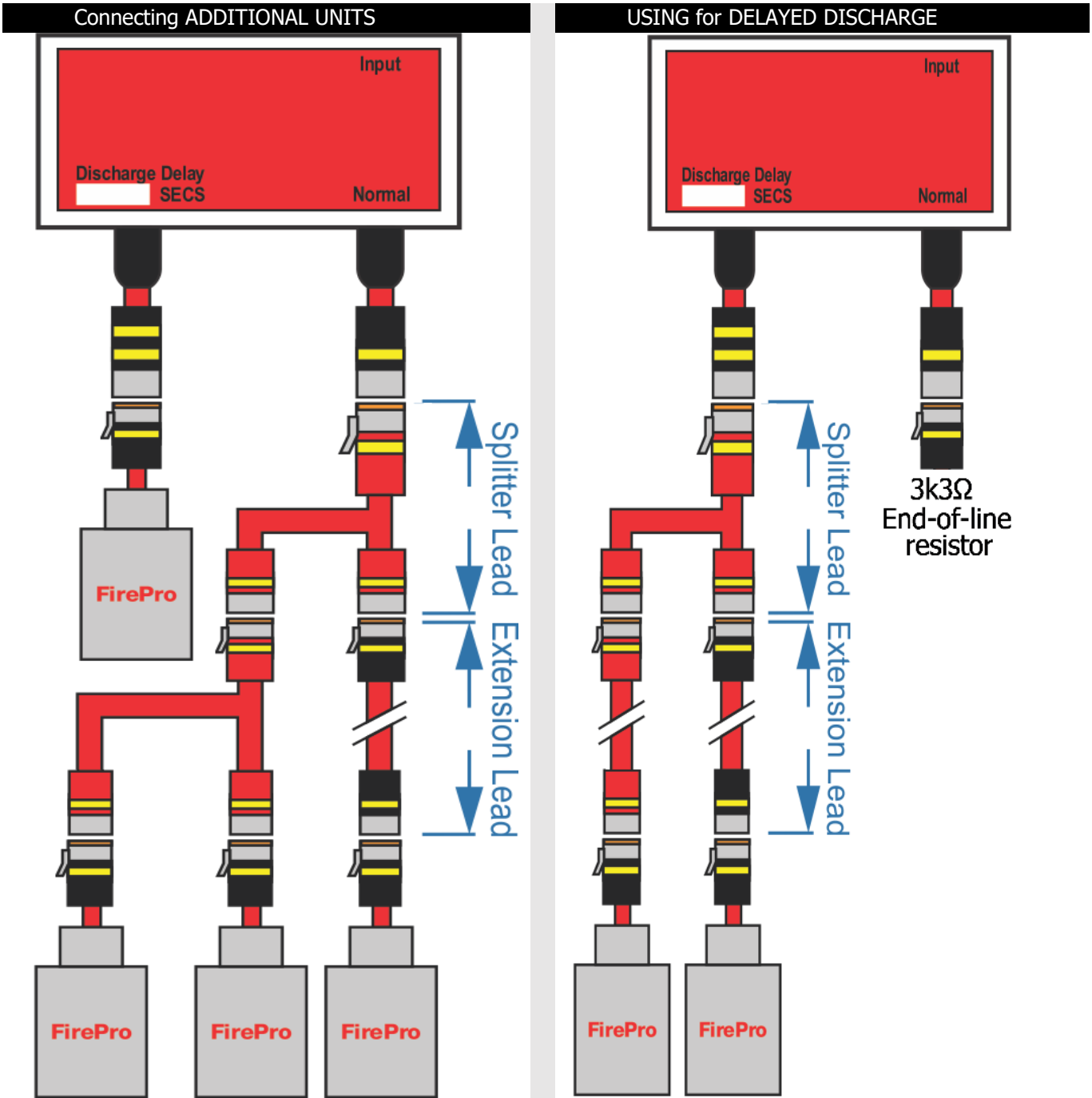

This shows 3 x FirePro Generators operating immediately (through the Normal Activation Circuit) and 1 FirePro unit firing after a delay.

This shows 2 x Firepro Generators operating ONLY AFTER DELAY. The 3k3Ω EOL resistor must be in place on the Normal output of a fault will display

3.4 Maximum FirePro units that may be connected

12v DC	2 units per output	24v DC	4 units per output
--------	--------------------	--------	--------------------



Discharge Delay Module Model 08850

3.5 Maximum Number of Discharge Delay Modules that can be used

Maximum of 10 Modules may be used on any single panel – from an electrical point of view. Actual maximum will be determined by delay programming. If more modules are required, consult with your supplier.

3.6 Mounting

For correct installation, the Discharge Delay Module must be mounted by bolts or screws through the mounting holes in the flange on both sides of the Module. **No penetrations are to be made through the casing of the panel.** The enclosure is rated IP65, so should be installed in a convenient location, away from where it may be affected by large amounts of water. The module does not need to be installed adjacent to the fire control panel.

3.7 Cabling Requirements

When constructing extension leads the supplied Deutsch Plugs must be used to ensure water-proof connections are made throughout the installation.

1. Cut cable to required length and strip outer insulation to approximately 25-30mm.
2. Strip inner insulation to approximately 6mm and using a Deutsch Crimping tool, fix pins to the exposed ends of the cable, including the earth where applicable.
3. Place heat shrink over the end of the cable. Identify correct socket on plug by the numbers/letter on the side of the plug and push through the gasket at the bottom of the plug until a click is heard and the pin is locked in place.

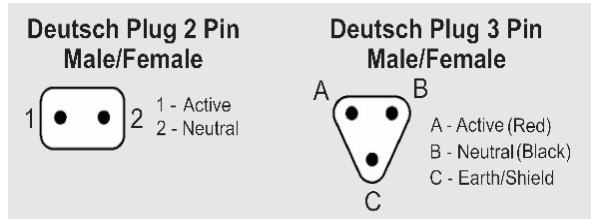

4. Place the locking mechanism inside the plug to ensure pins remain secure. (Male plugs; locking mechanism is orange. Female plugs; locking mechanism is green).
5. Using the heat shrink, seal the back of the plug.

Cables are colour coded for easy identification. When installing system, cables should be only connected to the correctly coded cable. Colour Coding for cables is as follows:

3.8 Multiple Discharges & Voltage Limitations

Like the FP-08450/8451 Fire Control Panel, the maximum number of FirePro generators able to be discharged by a Discharge Delay Module at each output is limited by the voltage of the main power supply. That is:

Colour	Circuit
	Red Power Supply
	Yellow 1 Activation
	Yellow 2 Activation Delayed
	Green 1 Detection 1
	Green 2 Detection 2
	Blue Discharge Advice
	Orange Siren/Strobe
	White Relay Output

Voltage 12vDC	Max = 2 Units	Voltage 24vDC	Max = 4 Units
---------------	---------------	---------------	---------------

If a risk area requires a greater number of FirePro generators to be discharged than the standard panel can provide, Discharge Delay modules can be used. The module will discharge generators in multiples up to the maximum as above.

If the number of FirePro generators connected to each output is greater than the maximum, the fire system will not operate.

When multiple FirePro generators are connected to a single output, they **must** be connected using the FP-08919 Splitter Lead (see 3.7 Connecting Multiple FirePro Generators).

3.9 Connecting Multiple Modules

Where multiple modules are used, the modules are to be connected using the "Discharge Delay" output (marked yellow 2) as below.

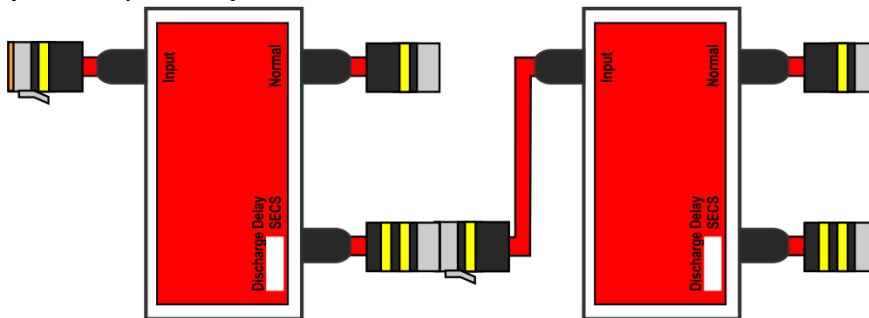

The FP-0450/8451 fire control panel activation sequence is limited to prevent accidental discharges when servicing. The maximum amount of time power is supplied to the activation circuit is 4.5 minutes. **Any programming to the Discharge Delay modules must not exceed this time limitation, or the modules will not operate.** (For example; if programmed M1 – 2.5min, M2 – 2.5min, M3 – 2.5min; module 3 will not operate).

Note: Discharge Delay modules **must not** be connected together by the "normal" output.

3.10 Connecting Multiple FirePro Generators

If multiple FirePro Generators are being installed on a single output, they must be connected using the FP-08919 Splitter Lead. The Splitter Lead enables the activation current to pass to connected FirePro generators and allows for continuous monitoring. Splitter Leads can be installed at any point on the activation circuit. For ease of install, servicing and more efficient field wiring, Splitter Leads should be installed in areas easy to access and should be used to minimise the required extension leads, and to bypass obstacles.

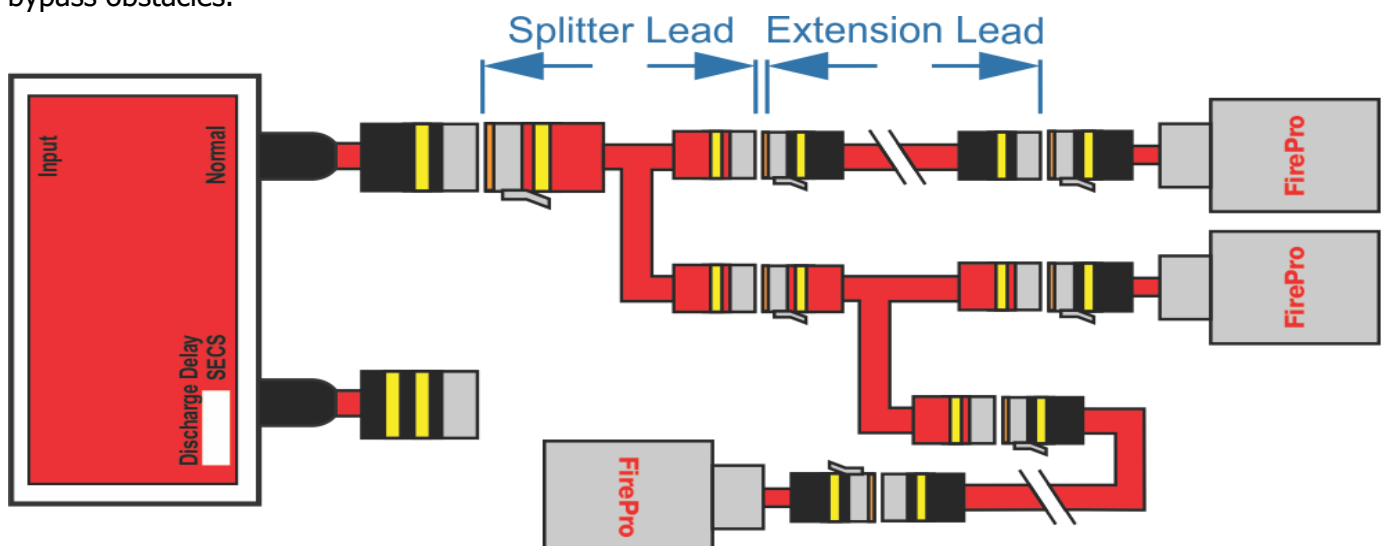

4 Installation

1. FirePro generators **must** remain disconnected until system is completed and fire control panel is no longer in a fault or alarm condition. The FirePro Universal Test Lamp (P/N FP-08800) can be used to take the panel out of a fault condition.
2. Ensure programming of fire control panel is set for extended discharge. (See FP-08450 or FP-08451 Manual)
3. Identify the FirePro generators to be activated in the initial discharge. The cable to these should be connected in series to the "Normal" output on the module (marked yellow 1), using the FP-08919 Splitter Lead where necessary. A Universal Test Lamp (P/N FP-08800) should be connected at each point where a FirePro generator has been installed.

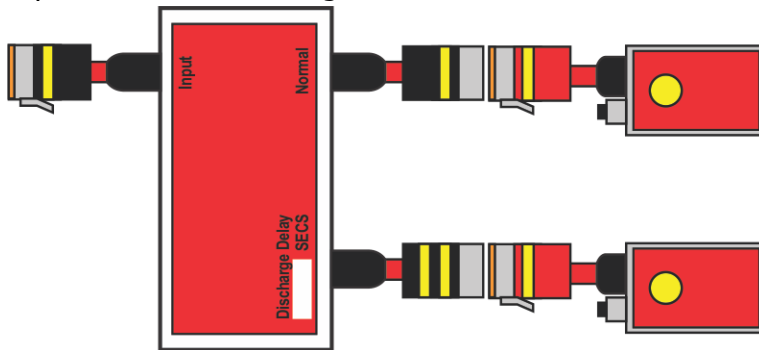

4. If only using the "Delayed Discharge" output, the 3k3Ω End-of-line resistor should be terminated into the supplied 3 pin deutsch plug and then connected to the "Normal" output on the module (marked yellow 1). The end-of-line plug should then be covered in heatshrink, and the heatshrink crimped, to avoid ingress of water into the circuit.

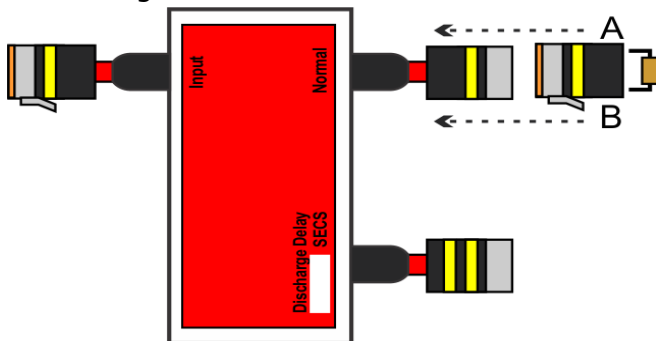

5. If using multiple modules, the next module should now be connected to the "Discharge Delay" output on the first module and step 2 repeated.
6. Identify the FirePro generators to be activated in the secondary discharge. The cable to these should be connected in series to the "Discharge Delay" output on the module (marked yellow 2), using the FP-08919 Splitter Lead where necessary. A Universal Test Lamp (P/N FP-08800) should be connected at each point where a FirePro generator has been installed.
7. The settings of the Discharge Delay Module can now be programmed to suit vehicle or site specific requirements. (See 6. Programming)



5 Wiring Diagram

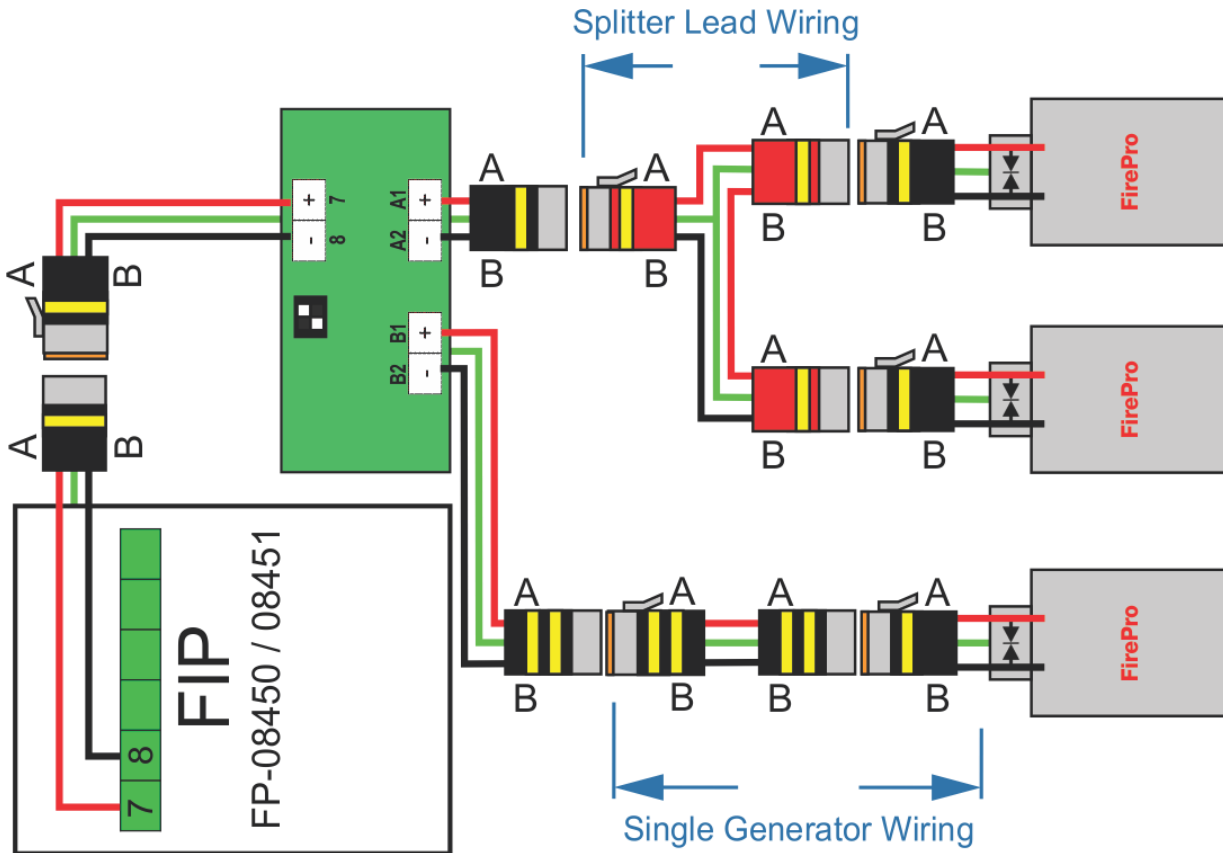

6 Programming

6.1 Programming Module Version 1 - 2.1

Fire Control Panel must be programmed for extended discharge. (See FP-08450 or FP-08451 Manual)

The Delay Timer Switch allows for the activation of the connected FirePro generators to be delayed for a period of up to 240 seconds after the FIP has entered an alarm condition. Individual programming of modules **must not** exceed 4.5 minutes (the total time power is applied to the activation circuit).

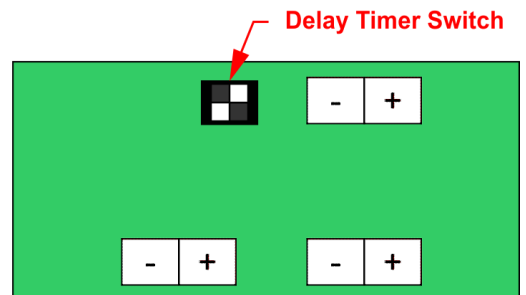

Mode	Delay Timer Switch	Switch 1	Switch 2
DELAY Set to 2 second		ON	ON
DELAY Set to 90 seconds		OFF	ON

Mode	Delay Timer Switch	Switch 1	Switch 2
DELAY Set to 150 seconds		ON	OFF
DELAY Set to 240 seconds		OFF	OFF



Discharge Delay Module Model 08850

Note: The settings of the module should be recorded in the service logbook and marked in the space provided on the front of the module.

6.2 Programming Module Version 3

When using a discharge delay module, the FP-08450/08451 Fire Control Panel must be programmed for extended discharge. (See FP-08450 or FP-08451 Manual)

The Delay Timer Switch allows for the activation of the connected FirePro generators to be delayed for a period of up to 255 seconds after the FIP has entered an alarm condition. Individual programming of modules **must not** exceed 4.5 minutes (the total time power is applied to the activation circuit).

Each switch on the Delay Timer has a separate delay value (in seconds) as follows:

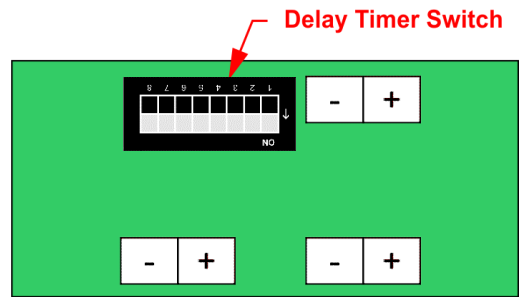

Delay Timer Switch									
Switch Number	1	2	3	4	5	6	7	8	
Delay Value	1 sec	2 sec	4 sec	8 sec	16 sec	32 sec	64 sec	128 sec	

The delay time is programmed by setting the required switches to the "OFF" position. When multiple switches are used, the delay values are added together, allowing for any delay time between 1 to 255 seconds to be programmed.

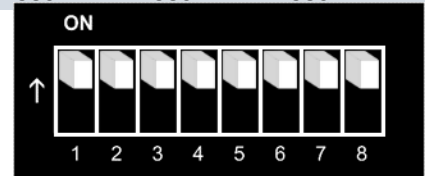

Example of common delay times can be programmed as follows:

Delay Time	Switch Positions	Delay Time	Switch Positions
2 seconds		60 seconds	
15 seconds		90 seconds	
20 seconds		120 seconds	
30 seconds		240 seconds	

Note: The settings of the module should be recorded in the service logbook and marked in the space provided on the front of the module.

7 Commissioning

Commissioning should be performed when the siren and shutdown relays are connected, and fire control panel is not in an alarm/fault condition.

1. Isolate and disconnect the any installed FirePro aerosol generators. This should generate a fault on the fire control panel.
2. Connect a FirePro FP-08800 Universal Test Lamps to "Normal" and "Discharge Delay" outputs.

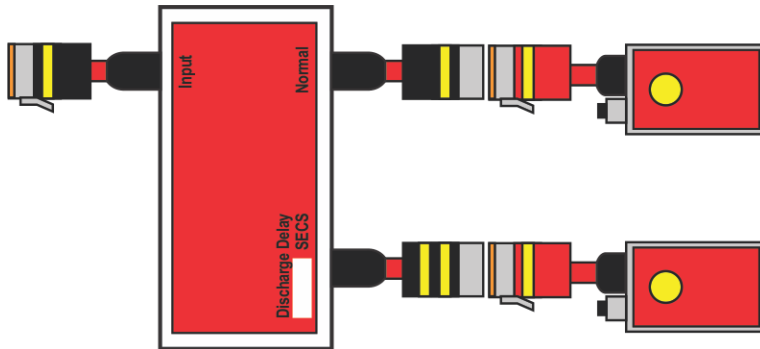

3. Perform an activation test, by pressing and holding the buttons on the fire control panel or through the detection circuits.
4. Ensure that all Test Lamps connected to the "Normal" output operate.
5. Observe the programmed delay and ensure that all Test Lamps connected to the "Discharge Delay" output operate.
6. Reset the fire control panel and all connected test lamps.
7. The fire control panel should no longer be in a fault or alarm condition.
8. Disconnect the FirePro FP-08800 Universal Test Lamp and reconnect all installed FirePro aerosol generators.

8 Servicing and Maintenance

Inspection and servicing of the installed fire system should occur in accordance with the relevant Australian Standards. This should include a visual inspection of the enclosure to ensure the seals are intact. Monitoring and operation of any installed modules should be tested as outlined in 7. Commissioning.

9 Operation

The Discharge Delay Module operates automatically when the fire control panel is in an alarm condition or the fire system has been manually activated. When activated, the FirePro generators connected to the "normal" output will discharge immediately, and initiate the programmed time delay for the secondary activation sequence. When the time delay is completed, the secondary activation will operate and the FirePro generators connected to the "discharge delay" output will discharge.

The Fire Control Panel will not isolate or reset until the activation sequence is complete.



10 Troubleshooting

Problem	Possible Cause	Solution
"Normal" Output/Primary Discharge not operating	Disconnected or poor connection to FirePro generators	Check connection of any extension cables.
"Discharge Delay" Output/Secondary Discharge not operating	Incorrect programming at fire control panel OR Disconnected or poor connection to FirePro generators	Check programming at fire control panel. Check connection of any extension cables.
Fault displayed on fire control panel (3 Beeps)	Disconnected or poor connection to FirePro generators OR Number of installed generators exceeds maximum OR FirePro Generators have discharged	Check connection of any extension cables. Inspect condition of FirePro Generators. Check internal battery of FirePro Test lamp.

For additional assistance contact your supplier.

11 Specifications

	FP-08850
Dimensions	140L x 65W x 30D
Enclosure material	Die Cast Aluminium
Ingress Protection	IP65
Operating Temperature	-40 to 85°C
Operating voltage	12-30VDC
Outputs	Discharge, max 2A at 12VDC and 2A at 24VDC
Outputs Fuse	Self-resetting Polyswitch trips at 2A
Discharge end-of- line	3K3 resistor
Fault-sensing	Discharge wiring open-circuit
Max no. of Modules	Up to 10 – If more modules are required, consult with your supplier. Actual maximum will be determined by delay programming.