

Contents

1	Specifications	2
2	Mounting	2
3	Terminals & Cable Size	2
4	Siren Output	3
5	Installation.....	3
6	Operation.....	3

1 Specifications

Dimensions	143mm high, 84mm wide, 31mm deep
Enclosure material – Ingress Protection	ABS plastics, black colour – IP44
Operating voltage	12-30VDC
Operating current	50mA on 12V 74mA on 24V
Power supply inputs	Main and backup
Number of fire detector zones	2 - 4
Acceptable detectors:	All commercial thermal, smoke and thermal detectors, manual call points, and LHD Cable.
Detector operating voltage	Same as power supply voltage
Max number of detectors per zone	30
Siren output	Max 1A at 12 or 24VDC
Output protection	1A resettable fuse on the siren output
Fault-sensing	Detector wiring open-circuit; Siren wiring open-circuit. Loss of internal 5V supply; Internal processor malfunction
End of Line Devices	Detector 4K7 Siren end-of-line: diode
Alarm sensing threshold	3.6V
Fault sensing threshold	0.53V
Operating temperature range	-40 to 85°C

2 Mounting

The panel is mounted vertically by means of 2 screws through the mounting holes as shown in the diagram below. It is necessary to complete the wiring before mounting the panel.

Open up the 2 parts of the panel by undoing the 4 screws at the base. There are 12 terminals on the circuit card in the panel cover. Wiring to the panel is through the base.

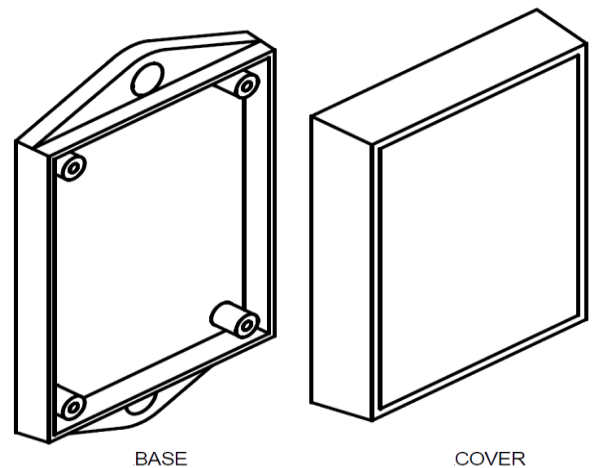

BASE

COVER

3 Terminals & Cable Size

Terminal	Function		Terminal	Function		Terminal	Function	
1	Main Power Supply	+	7	Not Used			Zone 1 Detection	+
2	Main Power Supply	-	8	Not Used			Zone 1 Detection	-
3	Backup Power	+	9	Zone 1 Detection	+		Zone 2 Detection	+
4	Backup Power	-	10	Zone 1 Detection	-		Zone 2 Detection	-
5	Siren Output	+	11	Zone 2 Detection	+		Zone 3 Detection	+
6	Siren Output	-	12	Zone 2 Detection	-		Zone 3 Detection	-
			13	NA			Zone 4 Detection	+
			14	NA			Zone 4 Detection	-

Maximum cable size: 1.5mm²

Accessories Provided with Panel	2 x 4K7 end-of-line resistors for the detection circuits
	1N4004 end-of-line diode for the siren
	1 1N5404 charger diode 1 operator's manual

4 Siren Output

The siren output can operate siren / strobe for Alarm events. Output is limited to 1A.

5 Installation

Main Power 12 or 24VDC

Backup Power (if installed) must be same voltage as Main.

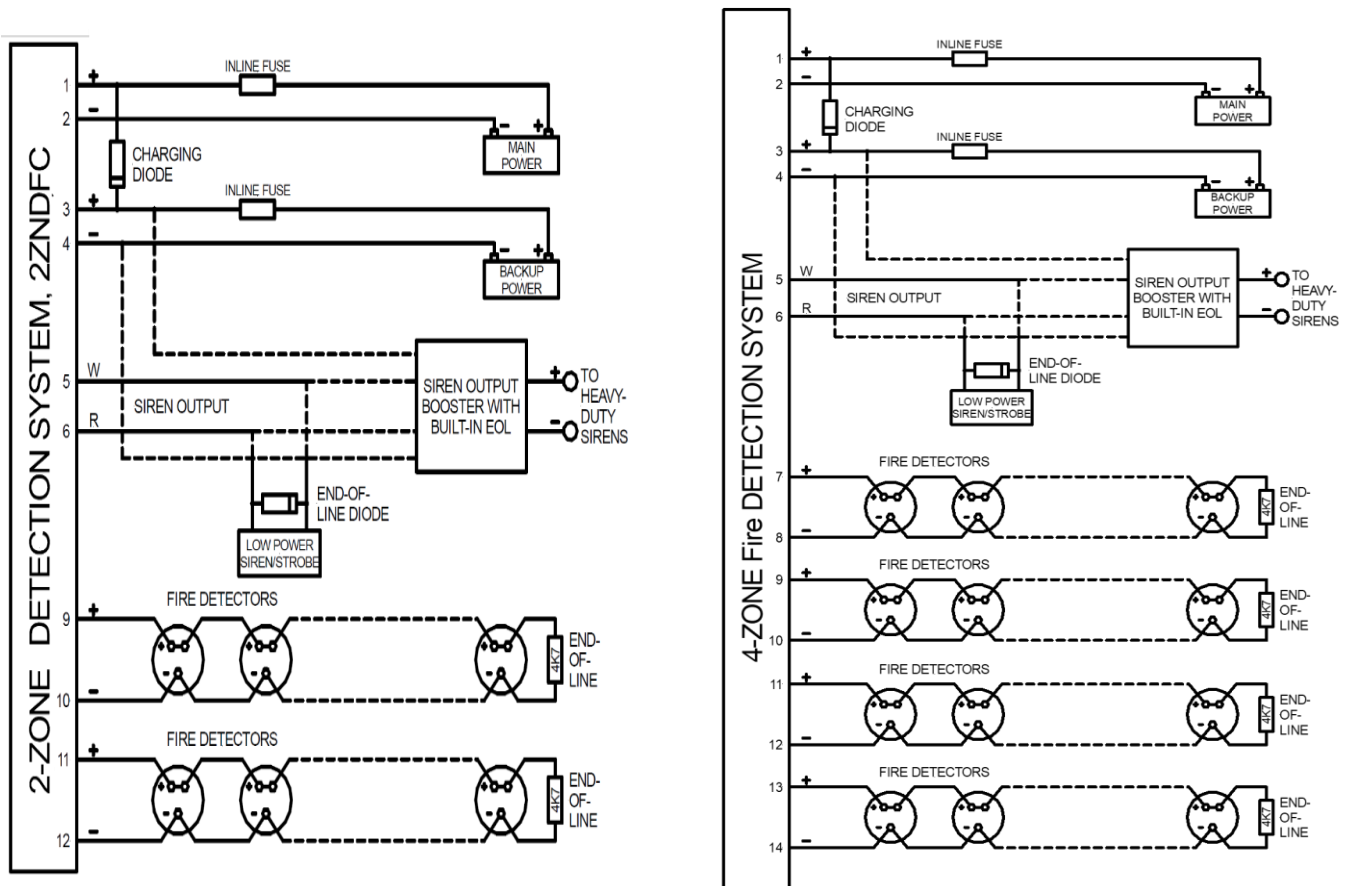

6 Operation

The FP-08458 Control Panel uses LED indicators to notify the operator of the condition of the control panel and each of the monitored circuits. If an LED is illuminated, it indicates the following:

Circuit	LED	Condition
Power 1	Green	Power supply is available
Power 2	Green	Power supply is available
Circuit 1 Alarm	Red	System is in alarm condition
Circuit 2 Alarm	Red	System is in alarm condition
Fault	Yellow	System is in fault condition and needs servicing
Isolated	Yellow	System has been isolated using buttons on panel

6.1 Switch

Pressing the switch until 1 beep is heard from the panel sounder, then releasing the switch. The panel is in isolation mode. The circuits continue to monitor the fire detectors for alarm and fault, and show the alarm and fault indications, but will not operate the siren. If an alarm or fault condition exists before the switch is pressed, then pressing the switch will silence the siren and the panel sounder, but will not cancel the alarm or fault indication. When a panel is in isolation, any change in the detector status, such as an alarm or a fault occurring, will cause the panel sounder to operate for 1 second as an alert of the status change, but the panel stays in isolation. Pressing the switch again will remove the isolation condition, and restore the panel to normal.

Pressing the switch until 1 beep, then 2 beeps, are heard from the panel sounder, then releasing the switch. The panel is in the isolation mode at the sound of 1 beep, and the detectors are reset at 2 beeps. The supply voltage to the detectors is removed for 1 second to reset the detectors. Pressing any single switch again will restore the panel to normal.

Pressing the switch until 1 beep, then 2 beeps, then 3 beeps, are heard from the panel sounder, then releasing the switch. The panel is put in the isolation mode at the sound of 1 beep, and the detectors are reset at 2 beeps. At 3 beeps the panel is in the TEST mode, at which all the panel LEDs, the panel sounder and the siren output are operated for 2 seconds in order to check if they are healthy. After the test, the panel automatically returns to normal.

6.2 Fault Indicators

A fault will be indicated if any monitored circuit connected to the panel is not complete. This could be caused by the devices connected or the wiring to each device. This will display as:

Internal Sounder	Fault LED	Fault
1 beep	On	Circuit 1 Alarm
2 beeps	On	Circuit 2 Alarm
3 beeps	On	Siren/Strobe Circuit

Inspection and testing of connections and components is required. If fault persists, contact your supplier.

6.3 Panel is Unresponsive

If the panel has become unresponsive, check the incoming power supply. Panel will operate down to approx. 9vDC. If incoming voltage is above this contact supplier.

6.4 Internal Faults

An internal fault cannot be isolated and will display as:

Internal Sounder	Fault LED	Fault
Continuous, steady beep	On	Internal 5vDC Supply OR Watch Dog Circuit
Continuous, pulsing beep	On	Internal Microprocessor

Internal faults can be rectified by powering down the panel and powering up again. This will reset the system to normal conditions. If the fault persists, contact your supplier.

6.5 Alarm Silence

To silence the internal sounder and any installed siren/strobes that have operated due to an alarm condition, press and hold Switch until a 1 beep is heard and the "Isolated" LED is illuminated.